

CENTRILOGIQ[®] LCR.iQ[™] / MASTERLOAD.iQ[™] I/O BOARD 84353 WIRING SCHEMATIC

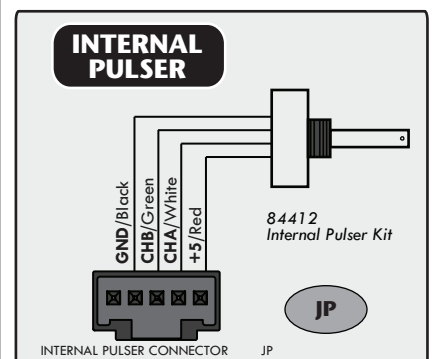
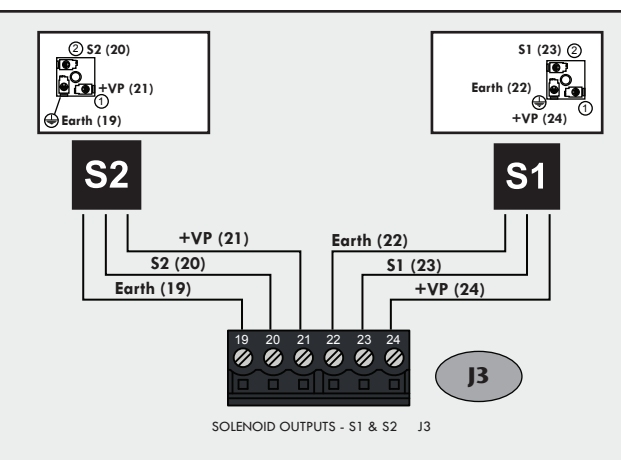
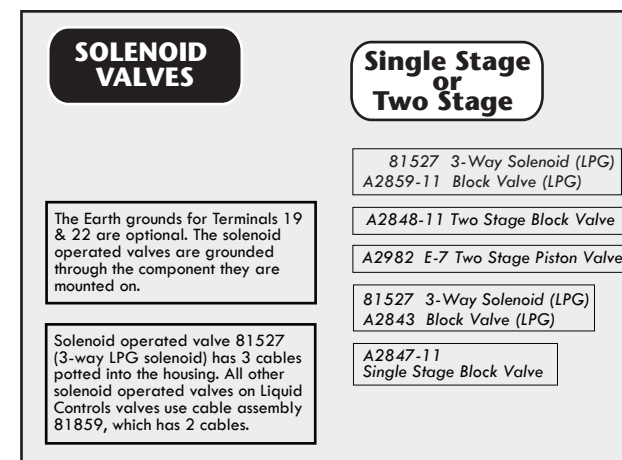
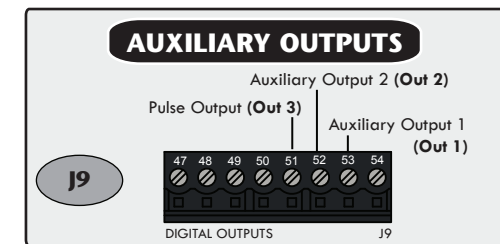
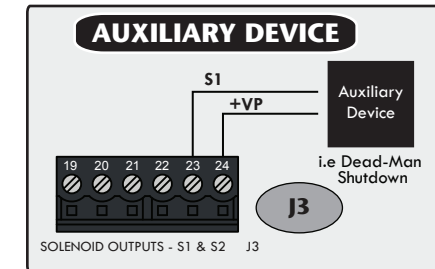
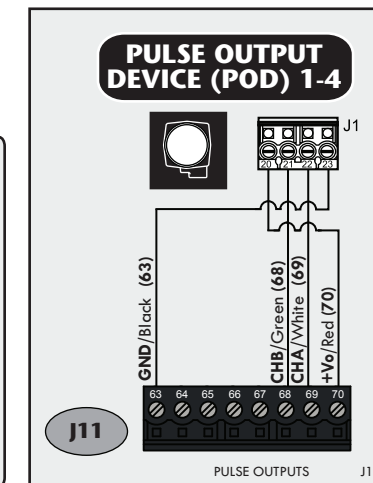
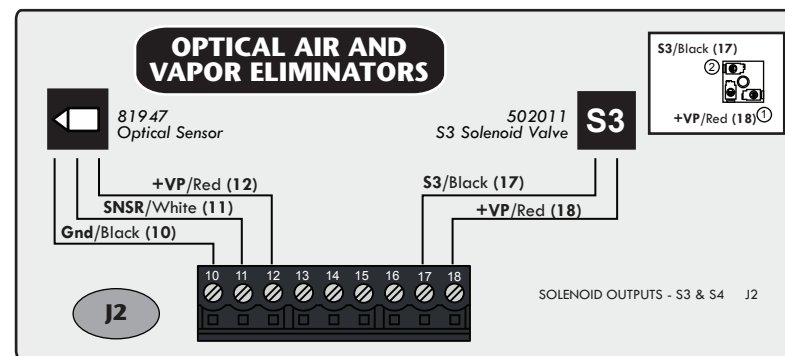
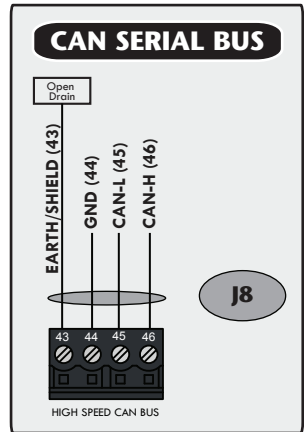
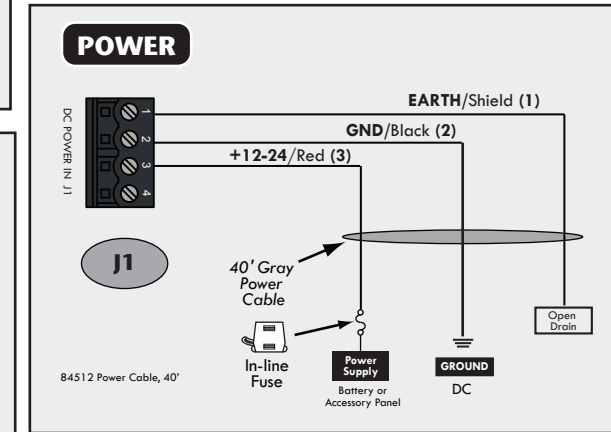
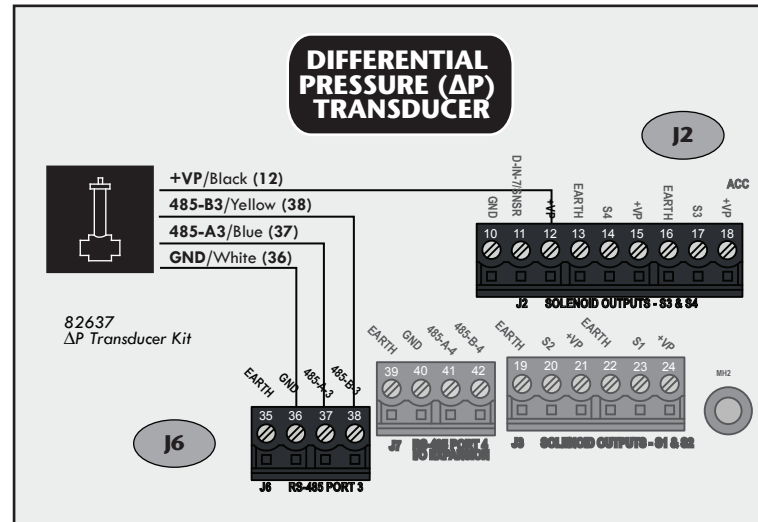
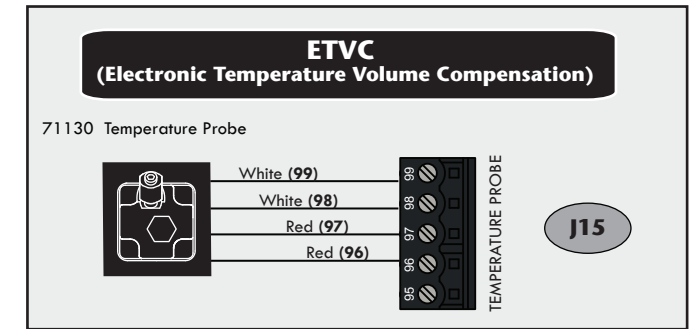
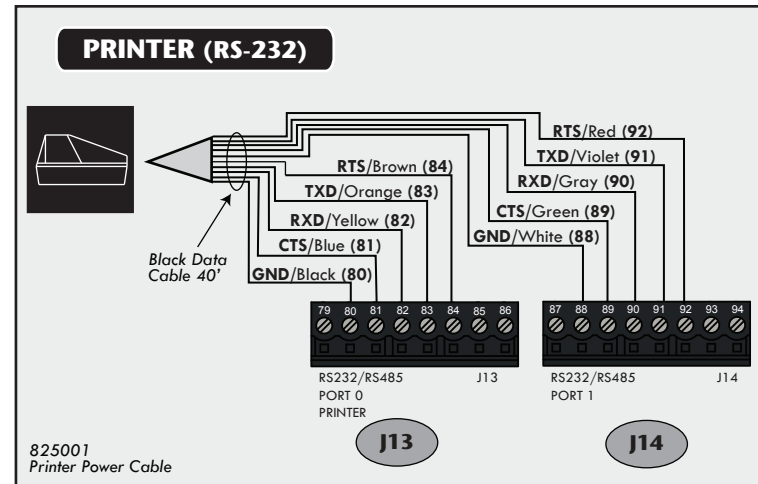
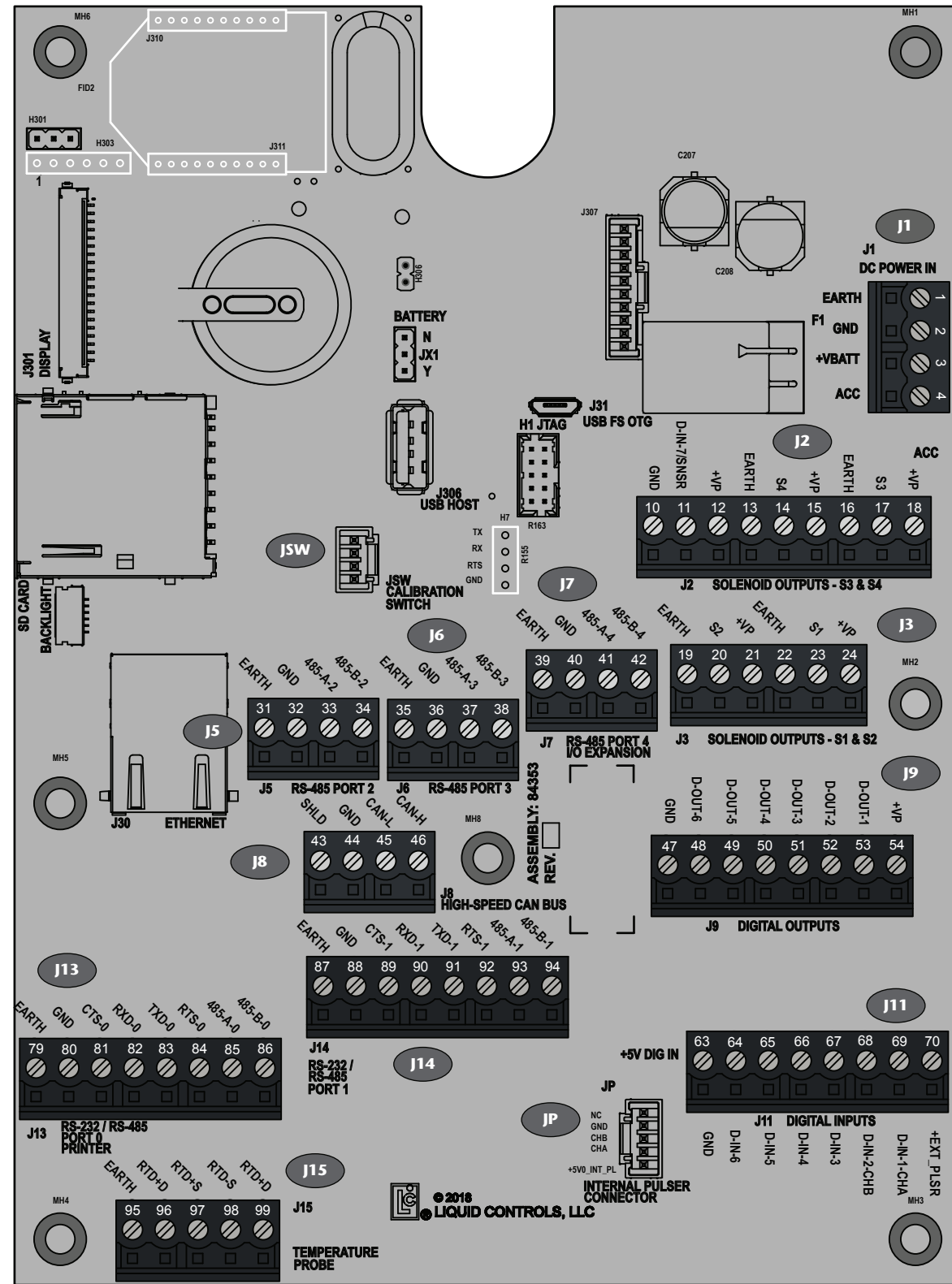

ESD PRECAUTION OPENING CENTRILOGIQ REGISTERS
 Before opening the CENTRILOGIQ register and handling the CPU board, it is important to discharge any ESD that may have built up on your person. To discharge ESD from your person, touch a well-grounded point such as the CENTRILOGIQ register housing, the meter, the truck piping, or the bumper. When the maintenance is complete and the CENTRILOGIQ register door is closed, the CPU board is protected from ESD by the CENTRILOGIQ register housing which is grounded to the chassis.