

EP15

ELECTRO-PNEUMATIC 2-STAGE VALVES

FEATURES & BENEFITS

- Liquid Controls' Lowest Pressure Drop, 2-Stage Presetting Option
- Ideal Valve for High Viscosity Petroleum Products such as Lubrication Oil
- Small Footprint and Compact Installation
- Highest Performing Option (for high flow rates, and low pressure drop) on Thinner Products such as Gasoline & Diesel
- Controlled by LCR-II or LCR600 registration and a truck's air system. The LCR600 is recommended in lubrication oil applications due to the 16 product calibrations in memory.

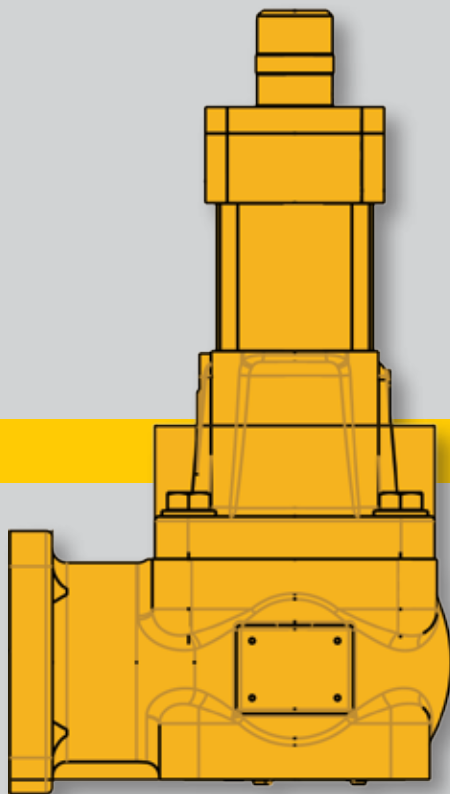

EP15

PARTS	MATERIALS
BODY	Aluminum
COVER	Aluminum
SHUTTER	Aluminum
GUIDE	Aluminum
DRIVE	Aluminum
SHAFTS	Stainless Steel
SPRINGS	Stainless Steel
SEALS	Viton, Buna
SCREWS	Carbon Steel, Stainless Steel

The Liquid Controls EP15 Electro-Pneumatic, 2-stage, Preset Valve is designed to control the flow of refined petroleum products including: diesel fuel, gasoline, fuel oils, kerosene, ethylene glycol, and lube oils. This valve can be integrated into a complete metering system containing an M15 or M25 Class 1 meter with electronic registration. Due to the less restrictive design, the EP15 valve provides the benefit of reduced pressure drop and higher potential flow rates, especially when handling higher-viscosity products. These valves can be installed directly on the meter outlet to provide a compact installation. An electronic register activates two solenoids to allow compressed air into one of two chambers in the valve. The high-flow chamber is supplied with air to allow for full flow when dispensing product. When nearing the preset point, the air supply to the high-flow chamber is shut off and supplied to the low chamber to open it, allowing for reduced flow. When the preset volume is reached, the low-flow chamber is shut off, closing the valve and stopping flow with minimal hydraulic shock to the system.

EP15

ELECTRO-PNEUMATIC 2-STAGE VALVES

SPECIFICATIONS

Temperature Rating

- -4° to 158°F (-20° to 70°C)

Pressure Rating

- Maximum non-shock working pressure: 150 PSI (10.5 BAR)

Environmental Rating

- Meets ATEX 94/9/EC Requirements

Max Flow Rate

- 264 GPM (1000 L/min)

Viscosity Range

- 30 to 20,000* SSU

*consult factory for higher viscosity liquid applications.

** High viscosity liquids not recommended for use with M25 class 1 meter.

Products

- CLASS 1 Refined Fuels (gasoline, fuel oils, diesel fuel, kerosene, ethylene glycol, and lube oils)

Safety

- Meets PED 97/23/EC Requirements

Materials of Construction

- CLASS 1
- Valve Body: Aluminum
- Internal Seals: Viton, Buna
- External Seals: Buna

Solenoids (Available Separately)

- Voltage: 12 VDC
- Maximum Pressure: 145 psi

Two-Stage Operation

- Reduced Flow Adjustable from 0 to 15% of full flow



DIMENSIONS

FRONT VIEW

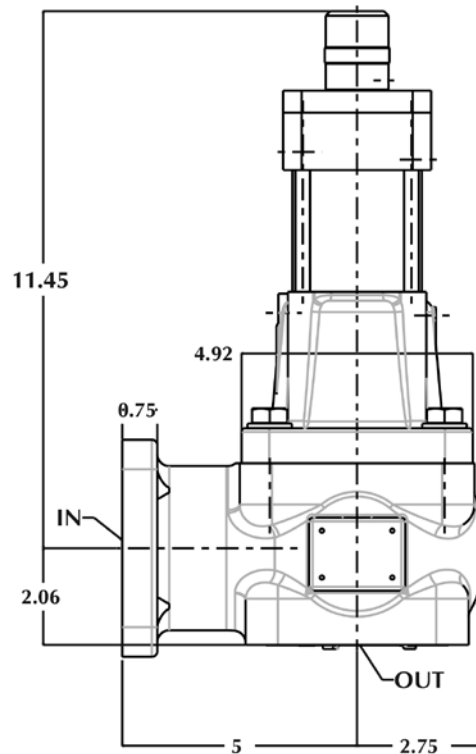

SIDE VIEW

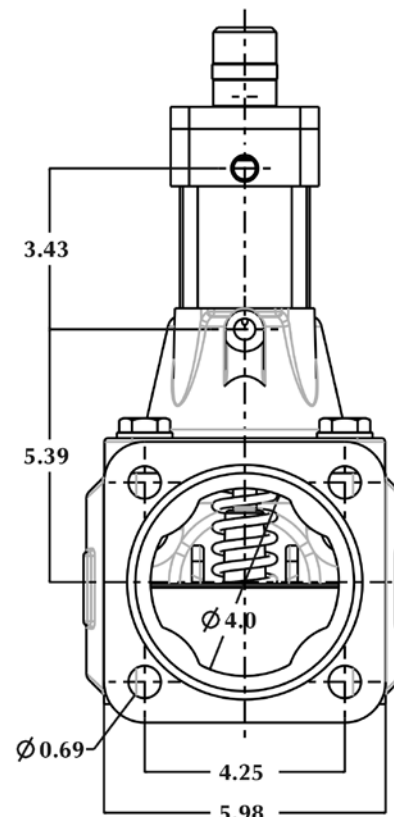

TOP VIEW

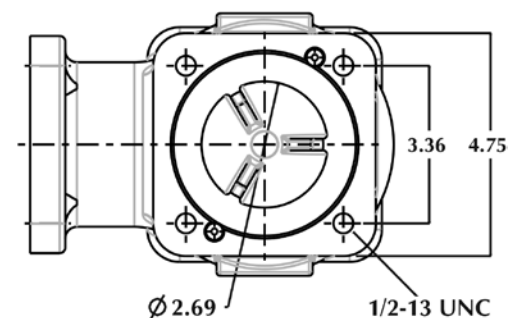

Dimensions shown are not for construction use. Consult factory when certified engineering drawings are required.