



LectroCount 81369 Retrofit Kit

M100-10RK
Pub. No. 500373

Assembly Instructions

Remove Existing Registration Equipment

1. Depressurize the meter completely.
2. Remove the four bolts on the bottom that fasten the register to the meter.
3. Remove the adjuster from the meter.
4. Remove the drive shaft and bearing
4. If the meter has a Temperature Volume Compensator (TVC), remove it as well.

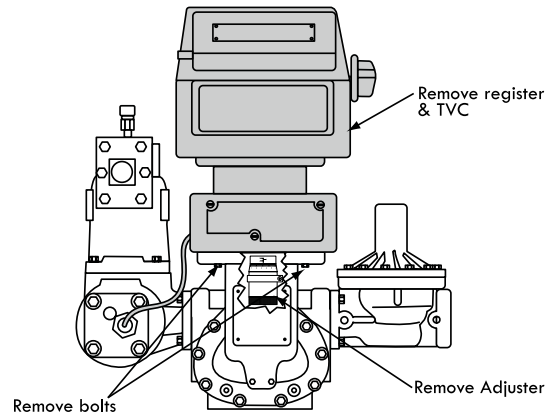

LC Meter Compensated

Mount the LectroCount register

1. Using the original face gear (in the 'right to left' or 'left to right' position), insert the new drive shaft and bearing.
2. Place the O-ring on the pulser drive shaft from the register.
3. Place the end of the shaft adapter on the pulser drive shaft located on the bottom of the register.
4. Place the cotter pin through the hole, and bend open the ends of the cotter pin.
5. Lower the register onto the meter, and insert the shaft adapter onto the hex shaft on the meter.
6. Securely bolt down the register. See below.

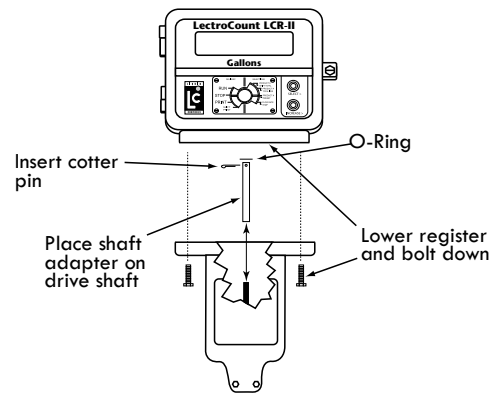

LC Meter

Apply Anti-seize

Apply anti-seize to all bolt threads to ensure easy removal at a later date.

Mounting Bolt Pattern

The LectroCount register base casting contains eight bolt holes in an industry standard bolt pattern. The holes are 1/2" deep and take 1/4"-20 screws.

If the installation necessitates that you fabricate a bracket, refer to the drawing to the right.

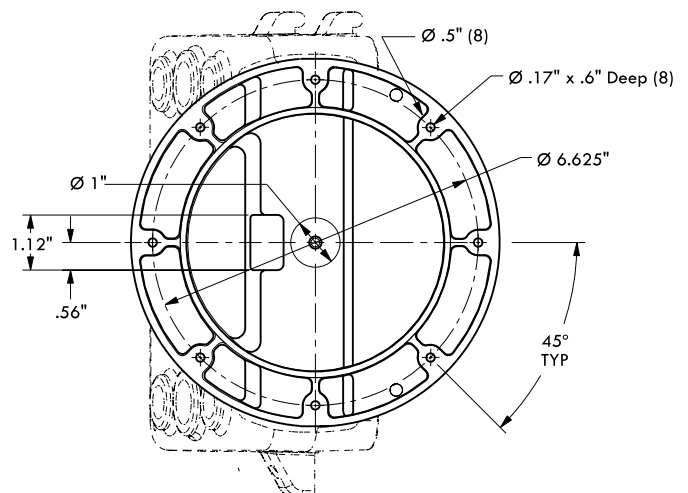

LectroCount Register Bolt Pattern