



Installation & Parts Manual

V-15, V-30, VS-3, and VS-4 Valves

**LIQUID
CONTROLS**
A Unit of IDEX Corporation

IDEX
IDEX CORPORATION

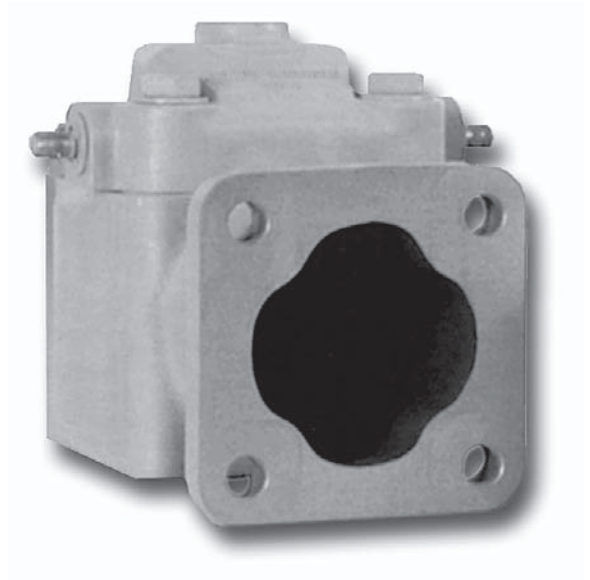

Table of Contents

Description	Page Number
General Information	2
Specifications	3
Application Class Description	3
V-15 & V-30 Valves	4-10
General	4
New Installations	5
Retrofit Installations	6-7
Disassembling	7-8
Reassembling	8
Setting the Dwell	9
Setting Zero Shutoff	10
VS-3 & VS-4 Valves	11-15
General	11
New Installations	12
Retrofit Installations	13
Disassembling	14
Reassembling	15
Illustrated Parts Breakdown	16-23
V-15 Valve	26-17
V-30 Valve	18-19
VS-3 Valve	20-21
VS-4 Valve	22-23

Publication Updates and Translations

The most current English versions of all Liquid Controls publications are available on our website, www.lcmeter.com. It is the responsibility of the Local Distributor to provide the most current version of LC Manuals, Instructions, and Specification Sheets in the required language of the country, or the language of the end user to which the products are shipping. If there are questions about the language of any LC Manuals, Instructions, or Specification Sheets, please contact your Local Distributor.

⚠ WARNING

- Before using this product, read and understand the instructions.
- Save these instructions for future reference.
- All work must be performed by qualified personnel trained in the proper application, installation, and maintenance of equipment and/or systems in accordance with all applicable codes and ordinances.
- Failure to follow the instructions set forth in this publication could result in property damage, personal injury, or death from fire and/or explosion, or other hazards that may be associated with this type of equipment.

General Information

Liquid Controls valves are designed for a wide range of applications and flow rates and have minimum head loss. Careful engineering and construction ensure smooth, accurate, and controlled operation.

The V-Series mechanically actuated piston valves are available in 3" and 4" sizes, and are designed for mounting on the meter outlet to provide tight shut-off with

smooth and easy operation regardless of system line pressure. The valves may be manually operated or connected via a mechanical linkage to a preset counter on the meter for single-stage closure (for low flow applications) or two-stage closure with dwell period to eliminate hydraulic shock. The valves are indexible in 90° increments for up, down, or side facing outlet.

Specifications

Model	Body & Seal Material	Companion Flanges	Working Pressure	Application Class*
V-15 (A-3600 Series)				
A3610	Aluminum with Viton Seal	3"	150 PSI (10.3 BAR)	1, 16
A3611	Aluminum with Viton Seal	3"	150 PSI (10.3 BAR)	1, 3, 14
A3612	Aluminum with Teflon Seal	3"	150 PSI (10.3 BAR)	1, 16
A3620	Aluminum with Viton Seal	3"	150 PSI (10.3 BAR)	3, 4, 14, 15
A3622	Aluminum with Teflon Seal	3"	150 PSI (10.3 BAR)	2, 14, 15
A3624	Aluminum with Viton Seal	3"	150 PSI (10.3 BAR)	2
V-30 (A-4600 Series)				
A4610	Aluminum with Viton Seal	4"	150 PSI (10.3 BAR)	1, 14, 16
A4611	Aluminum with Viton Seal	4"	150 PSI (10.3 BAR)	1, 3, 14
A4612	Aluminum with Teflon Seal	4"	150 PSI (10.3 BAR)	1, 14, 16
A4622A	Anodized Aluminum with Teflon Seal	4"	150 PSI (10.3 BAR)	2
A4623	Aluminum with Viton Seal	4"	150 PSI (10.3 BAR)	1, 3, 4, 15
A4624	Aluminum with Viton Seal	4"	150 PSI (10.3 BAR)	2

Model	Body & Seal Material	Companion Flanges	Working Pressure	Application Class*
VS-3 (A-36500 Series)				
A36501	Steel with Viton Seal, 275# Flange	3"	300 PSI (20.7 BAR)	1, 16
A36502	Steel with Viton Seal, 275# Flange	3"	300 PSI (20.7 BAR)	14
A36521	Steel with Teflon Seal, 275# Flange	3"	300 PSI (20.7 BAR)	16
A36522	Steel with Teflon Seal, 275# Flange	3"	300 PSI (20.7 BAR)	7
A36551	Steel with Viton Seal, 300# Flange	3"	300 PSI (20.7 BAR)	1
A36552	Steel with Viton Seal, 300# Flange	3"	300 PSI (20.7 BAR)	1
A36572	Steel with Viton Seal, 150# FF	3"	300 PSI (20.7 BAR)	27, 37
A36582	Steel with Teflon Seal, 150# FF	3"	300 PSI (20.7 BAR)	7, 27
VS-4 (A-46500 Series)				
A46501	Steel with Viton Seal, 275# Flange	4"	300 PSI (20.7 BAR)	1, 14, 16
A46502	Steel with Viton Seal, 275# Flange	4"	300 PSI (20.7 BAR)	14
A46521	Steel with Teflon Seal, 275# Flange	4"	300 PSI (20.7 BAR)	16
A46522	Steel with Viton Seal, 275# Flange	4"	300 PSI (20.7 BAR)	14
A46551	Steel with Viton Seal, 300# Flange	4"	300 PSI (20.7 BAR)	14
A46552	Steel with Viton Seal, 300# Flange	4"	300 PSI (20.7 BAR)	14

Applications Class Description	Class Number
Refined petroleum products	1
Aviation and jet fuel	2
Variety of products including: liquid sugars, sweeteners, syrups, & vegetable oils	3
Treated waters & solvents where no red metals are allowed	4
Chlorinated solvents	7
Crude Oil	14
Oil-based & Water-bases latex products, polyester, resins, herbicides, & nitrogen fertilizers	15
General Solvents, 200 proof alcohol	16
Alkaline pH Liquids including: latex products, adhesives, & liquid fertilizers	27
Sodium Hydroxide solutions, high sulfur crude oil, & alkaline pH liquids	37

V-15 & V-30 Valves

General

V-15 valves are designed for use on M-15 and M-25 positive displacement flowmeters; V-30 valves are for use on M-30, M-40, and M-60 positive displacement flowmeters.

V-15 & V-30 valve operation is smooth and easy regardless of the line pressure since the vector forces are directed at right angles to the valve opening mechanism and are never in opposition to it.

Depending on the preset, the valve may be operated as either a two-stage valve with dwell period shut-off or as a single-stage valve with abrupt shut-off. Single stage valves are recommended when the application flow rates are low.

How V-15 & V-30 Valves Work

Inside the valve housing, a cylindrical bore connects the valve inlet and outlet. Contained within the bore is a piston assembly. Measured liquid exiting the meter outlet is blocked from entering the valve inlet by the piston and seal.

As the meter operator shifts the handle to the open position, a mechanical linkage connecting the valve to the preset counter trip ring causes a latch to engage and hold the valve open allowing liquid to flow.

In the open position, the valve handle assembly compresses the piston spring and pulls the piston shaft and the piston away from the valve outlet. As the piston is pulled away, it disconnects from the inlet seal, allowing liquid to flow.

In most metering applications, closing the valve is a two-stage process. At a predetermined dwell period, the preset counter, while counting down to "0", releases a latch mechanism, allowing the valve to close to approximately 10% of full flow. This initial closing causes the piston inside the valve to slide toward the outlet, restricting product flow.

As liquid is blocked by the piston, some product passes through the valve. The dwell period prevents hydraulic shock while permitting the preset counter to register the remaining flow.

As the preset counter reaches "0", the preset counter trip ring disengages from the dwell position to the fully closed position. This action releases the valve handle and relaxes the piston spring, permitting the piston to contact the outlet ring seal and complete its closure, stopping product flow.

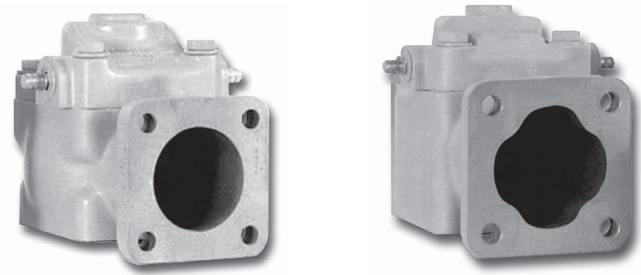

Figure 1: V-15 & V-30 Valves

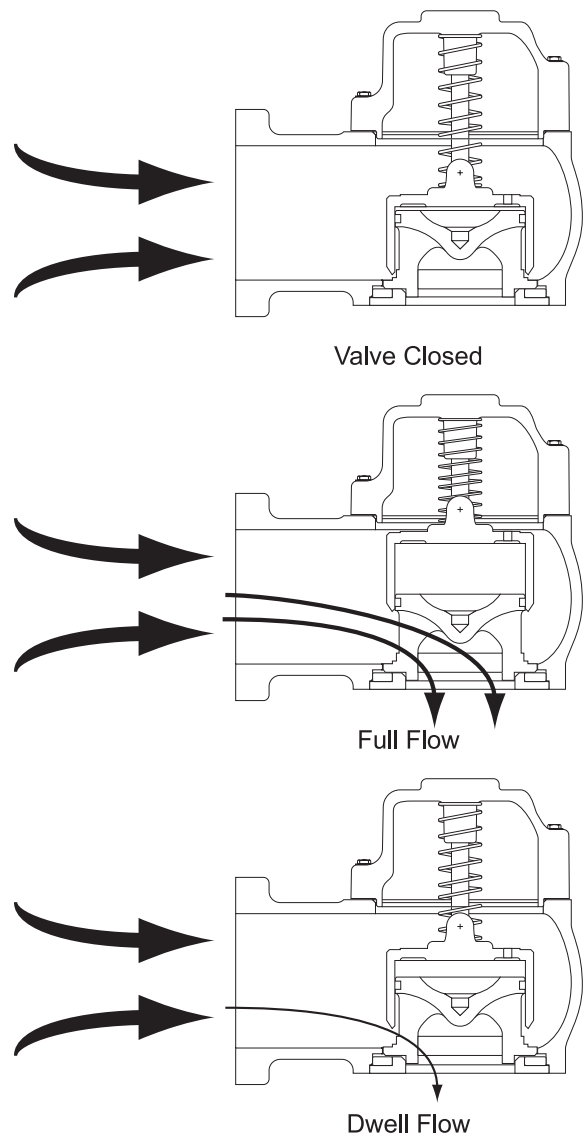

Figure 2: Valve Operation

Accessories

Flanges

Flanges are offered in 3 and 4 inch BSPT and NPT sizes and weld types. Material of construction is aluminum. Teflon, Viton, and Buna seals and gaskets are available.

Linkage and Valve Handles

Valve handle and linkage assemblies (Figure 3) are accessories used when normal manual ON and OFF valve operation is desired. Different handle and linkage configurations can be ordered separately for field installations.

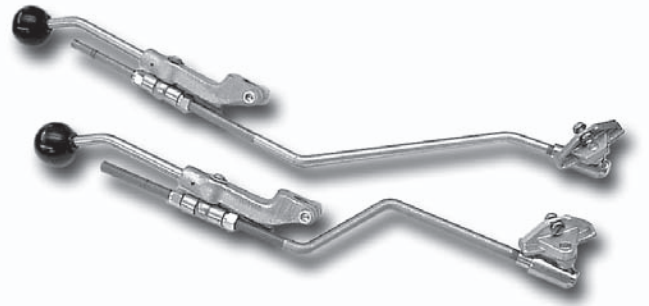

Figure 3: Linkage Assemblies

There are two valve handle options. When using a mechanical preset, the 40984 curved handle (provided as part of the linkage assembly) is used with both the V-15 and V-30 valves. For applications without a preset, the A3750 faucet valve handle kit is used.

Unlike the V-7 Valves, the V-15 and V-30 linkage assemblies come complete with the 40984 handle. The available Linkage Assemblies for V-15 and V-30 valves are listed in the table below.

V-15 Valve Linkage Assemblies		
Part Number	Style	Description
A3710	Offset	Linkage Assembly for LC Preset
A3711	Offset	Linkage Assembly for LC Preset
A3712	Offset	For use with M-15 with a V-R Preset & Microswitch
A3718	Offset	For use with M-30 Class 7 Meters with LC Preset
A3730	Offset	For use with M-15 through M-60 & MS-15 through MS-75 Spec with LC Preset

V-30 Valve Linkage Assemblies		
Part Number	Style	Description
A4710	Offset	Linkage Assembly for LC Preset
A5712	Offset	For use with M-60 and MS-30 without a Counter Extension

Installation

New Installations

When ordered with a new metering system, the V-15 or V-30 Series Valve is supplied mounted to the outlet side of the meter as shown in Figure 4. A liquid line must be connected to the flange on the outlet side of the valve or to the accompanying check valve. The flange connection on the V-15 valve is 3" BSPT or NPT. The flange connection on the V-30 valve is 4" BSPT or NPT. Weld-type flanges are available as an option.

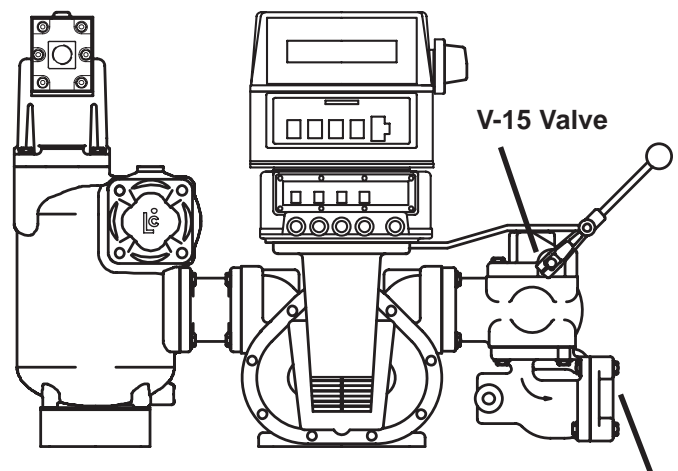

Figure 4: V-15 Valve Installed

V-15 & V-30 Valves - Installation

Retrofit Installations

⚠ WARNING

Relieve Internal Pressure

All internal pressure must be relieved to zero pressure before disassembly or inspection of the meter or any of the meter accessories.

Serious injury or death from fire or explosion could result from maintenance of an improperly depressurized and evacuated system.

Depending on the existing configuration, adding a V-15 or V-30 Valve may require modification of the outlet piping.

After the internal pressure is relieved from the system, drain all the fluid from the flowmeter and accessories. The outlet line can then be disconnected from the flowmeter.

Installing the Valve

The V-15 or V-30 valve is installed on the outlet side of the flowmeter. The valve may be installed in one of four orientations as shown in Figure 5. Determine the orientation desired and then attach the flowmeter using the four bolts and washers provided. Tighten the bolts in a crossing pattern.

Installing the Linkage Assembly

The handle and linkage assembly is provided with the V-15 and V-30 Valves. The handle and linkage may need to be repositioned depending on the valve orientation. Refer to Figure 5 to determine the handle and linkage positions based on the valve orientation.

The valve handle mounts on either side of the valve shaft. Mount the valve handle to the valve shaft and tighten. With the handle securely mounted to the valve shaft, the linkage assembly can be connected to the preset ring located under the mechanical register.

The linkage assembly connects to the preset ring via the ball joint extension (Figure 6a). The ball joint extension is mounted using the screw and nut provided.

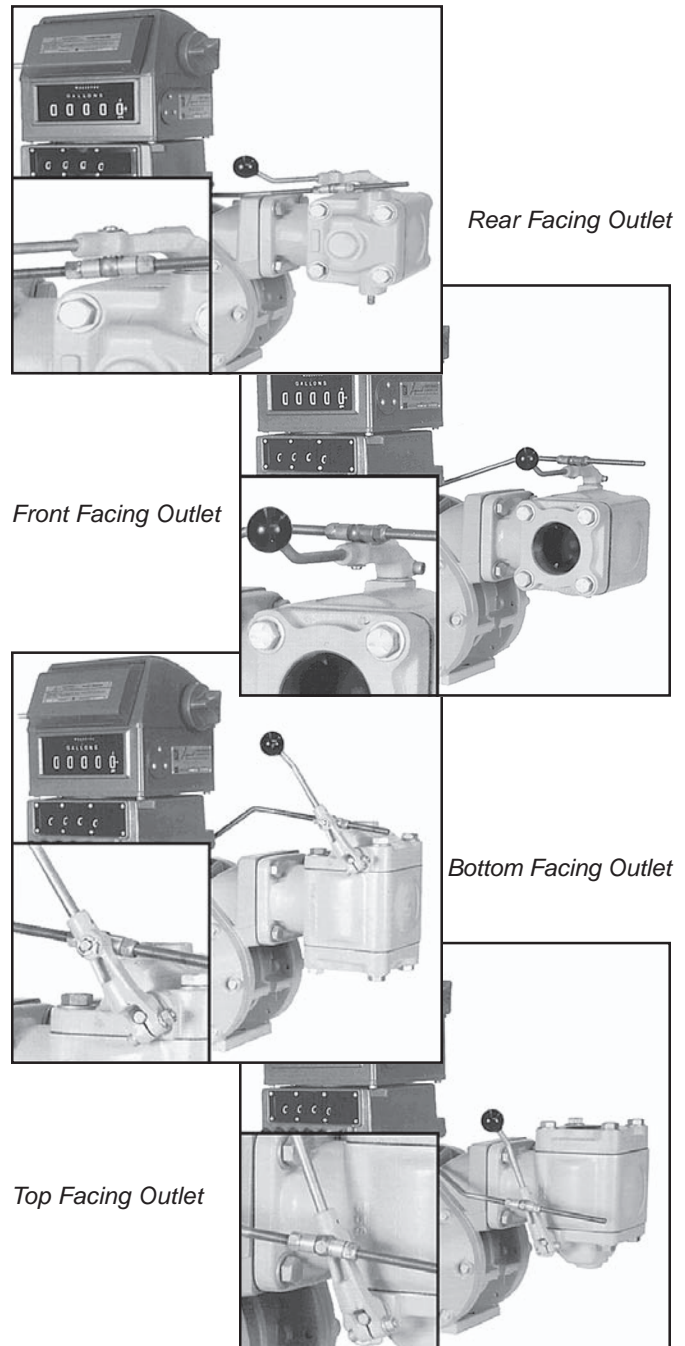

Figure 5: Valve Orientations

V-15 & V-30 Valves - Installation

Retrofit Installations (continued)

Mount the ball joint extension to the preset ring by threading the screw into one of the holes at the back of the register assembly. Thread the nut in place on the screw.

With the ball joint extension secure on the preset ring, attach the linkage assembly (Figure 6b). The linkage assembly may require adjustment in order to mount to the ball joint extension. If this is the case, either loosen the handle and reposition on the valve shaft, or loosen the nuts at the handle pivot (Figure 6c).

Once the handle and linkage assembly is secure, proceed with setting the dwell and zero shut-off as described on Pages 9-10.

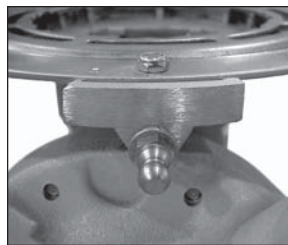

Figure 6a: Ball Joint

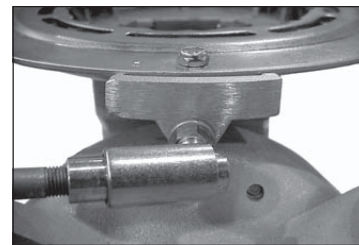

Figure 6b: Linkage Attached to Ball Joint

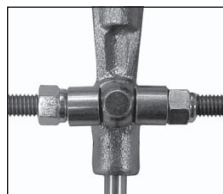

Figure 6c: Handle Pivot

Disassembling the Valve

The V-15 & V-30 Valves are under pressure from the compression spring. The safest method for opening the valve for service or maintenance is to place the valve on a flat surface with the valve outlet facing down.

1. Loosen the four bolts (Items 610 & 611) located on the valve cap (Item 124). The compression spring will exert a force on the cap and push it up.
2. When the four bolts are almost completely removed, check to see if the compression spring is still exerting a force on the cap. If not, remove the four bolts and washers completely. If there is still force on the cap, remove two screws from opposite sides of the cap. While bracing the cap with one hand, remove the other two bolts and carefully release the cap until the compression spring exerts no force.
3. Note the orientation of the cap and valve handle. Remove the cap (Item 124). The internal components are attached to the cap and will come out of the valve housing with the cap.
4. To disassemble the cap assembly, it will be necessary to remove the four cotter pins which hold the cup (Item 133) to the links on each side of the cup. This is only necessary when replacing the compression spring or the cup.
5. To replace the dashpot washer, remove the retaining ring on the end of the guide shaft.

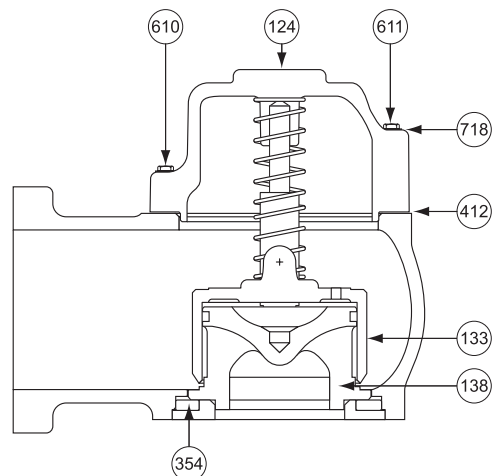

Figure 7: V-15 Valve

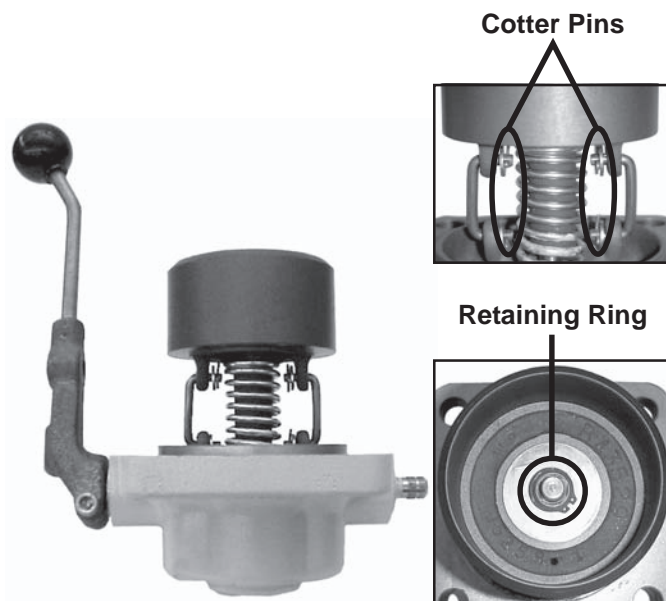

Figure 8: Piston

V-15 & V-30 Valves - Reassembly

Disassembling the Valve (continued)

6. Reposition the valve assembly so that the outlet side is facing up.
7. Remove the two screws (Item 615) that hold the guide (Item 138) and seal in place and remove the guide and seal.

The valve shaft (Item 368) is not removable, but it is not necessary to remove it in order to inspect or replace the O-Rings and bearings of the valve shaft.

8. Remove the retaining ring (Item 564) from one side of the valve shaft.
9. Remove the shaft seal (Item 270), the bearing (Item 140) the O-Ring (Item 455), the inner bearing (Item 260) and the O-Ring (Item 450).
10. Inspect and replace these components as needed.
11. Repeat steps 8-10 for the other side of the valve shaft.

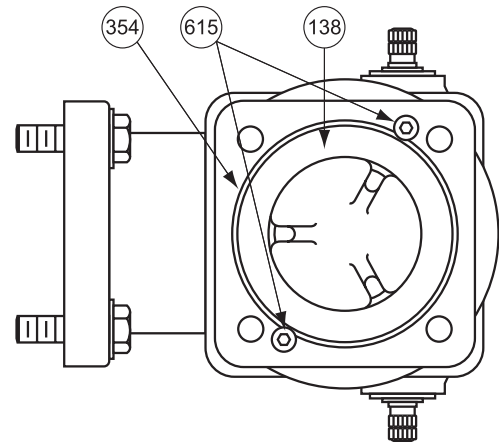

Figure 9: V-15 Valve Guide

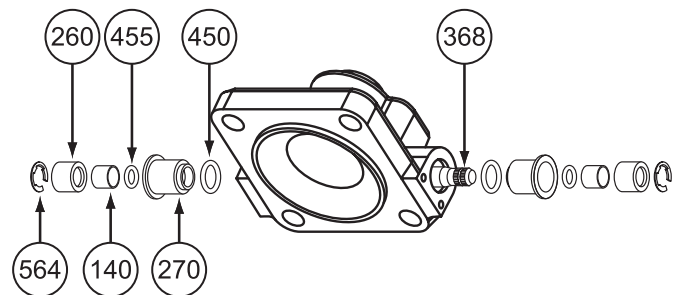

Figure 10: V-15 Valve Cap

Reassembling the Valve

For reassembly, refer to Figures 7 & 10 or the parts breakdown on Pages 17 & 19.

1. Place the seal (Item 354) into the valve housing.
2. Place the guide (Item 138) into the valve outlet.
3. Secure the seal and guide using the two screws (Items 615). Tighten the screws.
4. Turn the valve so that the outlet faces down.
5. Reassemble the valve by placing the dashpot washer and retaining ring on the end of the guide shaft.
6. Place the complete cap assembly on the valve housing remembering to orient the valve handle in the same position as it was prior to disassembling.
7. Insert the four screws and washers into the valve

cap and tighten by alternately tightening each screw a few turns so that the cup (Item 133) slides evenly over the guide (Item 138).

8. When the cap rests against the valve housing evenly, tighten all four screws in a crossing pattern.
9. If the valve shaft components were removed for inspection or replacement, reassemble the valve shaft components following the drawing above.
10. Insert the O-Ring (Item 450), the Inner bearing (Item 260), the next O-Ring (Item 455), the next bearing (Item 140), the shaft case seal (Item 270) and secure with the retaining ring (Item 564).

This completes reassembly. The valve may be placed back in service. Refer to Pages 6 & 7 for installation instructions.

Setting the Dwell

Correct linkage adjustments avoid hydraulic shock.

Hydraulic shock occurs when a volume (mass) of liquid moving at a high rate through a pipeline is stopped by a valve that is suddenly closed. When the flow stops abruptly, the mass of liquid acts as a battering ram, causing a shock effect within the metering system. The meter housing and internal parts receive the full impact since the valve is located at the meter outlet. The greater the mass, length of pipeline or velocity, the greater the hydraulic shock and the greater the damage possibilities.

To prevent damage from hydraulic shock, a slow closure, two-stage valve and preset should be used with the meter. In some instances, mass, length of pipeline, or velocity are of such a magnitude that using a two-stage valve is ineffective. In this case, an impact absorbing, air cushioning device should be used as an added accessory.

The linkage between the valve and preset can be adjusted to increase or decrease product flow during the dwell period. To make adjustments shift the valve handle to the slow flow or dwell setting. (See the preset counter manual for more detail).

Turn the two 9/16 inch linkage nuts (Figure 11) located on either side of the bracket to adjust the linkage for proper dwell.

- On a right to left flow meter the nuts are moved to the right to increase dwell flow and moved to the left to decrease dwell flow.
- On a left to right flow meter the opposite is true. Moving the nuts to the right decreases dwell flow and moving nuts to the left increases dwell flow.

While adjusting the nuts, it is important to hold the linkage rod firmly so that it does not move.

Proper adjustment is obtained when the far right wheel of the preset counter (Figure 12) slows to a readable rate and the characteristic dwell hiss is heard. Dwell hiss is a low, resonating sound caused by slow moving product through the valve.

When this is accomplished, tighten the adjusting nuts ensuring that the linkage bracket is free to move, but there is little slop between the linkage bracket and the adjusting nuts.



Figure 11: Linkage Adjustment



Figure 12: Preset Counter

V-15 & V-30 Valves - Installation

Adjusting Zero Shutoff (LC Preset)

Because of the interaction between the valve and the preset counter, some adjustment may be needed to the preset counter so that components work at optimum efficiency. Preset Counters assembled with meters at the factory are adjusted for proper shut-off timing. Due to meter system variations, such as flow rate and viscosity, it may be necessary to make zero shut-off adjustments.

At least two test runs should be completed before any adjustments are made. On all presets, make a test run using a value large enough to permit the meter to reach its normal flow rate. If it is determined after testing that an error in zero shut-off is indicated, correct the zero shut-off in the following manner.

1. Start by removing the eight screws that hold the bezel to the preset counter.
2. Remove the bezel (Figure 13a).
3. Press the preset button directly below the units wheel until the set screw appears in the opening.
4. Use a screwdriver to loosen the set screw on the notch ring located on the left side of the units wheel (Figure 13b). This allows for the repositioning of the notch ring and units wheel.
- 5a. Early Shutoff
To correct an early shut-off, hold the notch ring in place (Figure 13c) and move the numbers wheel down enough to correct the misalignment.
- 5b. Late Shut-off
To correct a late shut-off, hold the notch ring in place (Figure 13c) and move the numbers wheel up enough to correct the misalignment.
6. After each adjustment, carefully tighten the set screw. Take care not to strip the threads with excessive torque.
7. After running two test runs, the zero should be centered in the window. If not, reset the notch ring and repeat the procedure.
8. Ensure that the set screw is tight and remount the bezel.

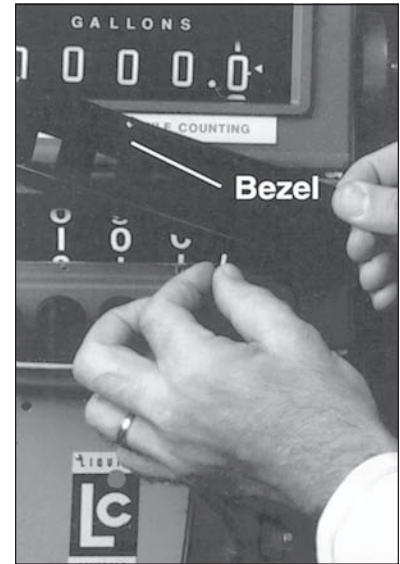

Figure 13a: Bezel Removal

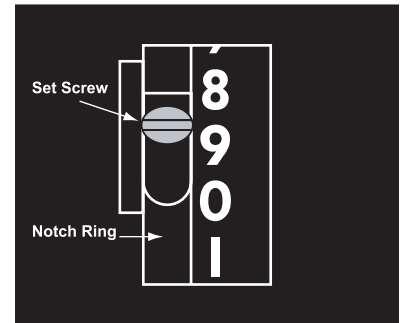

Figure 13b: Set Screw & Notch Ring

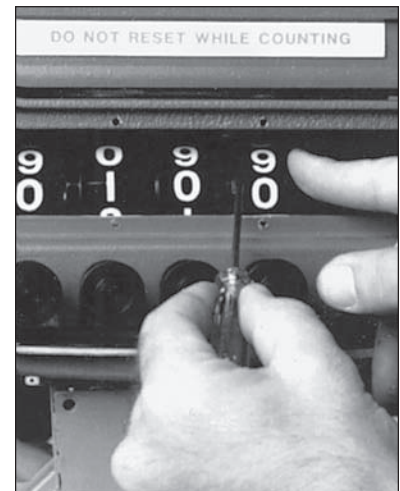

Figure 13c: Set Screw Adjustment

General

VS-3 valves are designed for use on MS-30 and MS-40 steel case, positive displacement flowmeters; VS-4 valves for use on MS-75 steel case, positive displacement flowmeters.

VS-3 & VS-4 valve operation is smooth and easy regardless of the line pressure since the vector forces are directed at right angles to the valve opening mechanism and are never in opposition to it.

Depending on the preset, the valve may be operated as either a two-stage valve with dwell period shut-off or as a single-stage valve with abrupt shut-off. Single stage valves are recommended when the application flow rates are low.

How VS-3 & VS-4 Valves Work

Inside the valve housing, a cylindrical bore connects the valve inlet and outlet. Contained within the bore is a piston assembly. Measured liquid exiting the meter outlet is blocked from exiting the valve outlet by the piston and seal.

As the meter operator shifts the handle to the open position, a mechanical linkage connecting the valve to the preset counter trip ring causes a latch to engage and hold the valve open allowing liquid to flow.

In the open position, the valve handle assembly compresses the piston spring and pulls the piston shaft and the piston away from the valve outlet. As the piston is pulled away, it disconnects from the outlet seal, allowing liquid to flow.

In most metering applications, closing the valve is a two-stage process. At a predetermined dwell period, the preset counter, while counting down to "0", releases a latch mechanism, allowing the valve to close to approximately 10% of full flow. This initial closing causes the piston inside the valve to slide toward the outlet, restricting product flow.

As liquid is blocked by the piston, some product passes through the valve. The dwell period prevents hydraulic shock while permitting the preset counter to register the remaining flow.

As the preset counter reaches "0", the preset counter trip ring disengages from the dwell position to the fully closed position. This action releases the valve handle and relaxes the piston spring, permitting the piston to contact the outlet ring seal and complete its closure, stopping product flow.

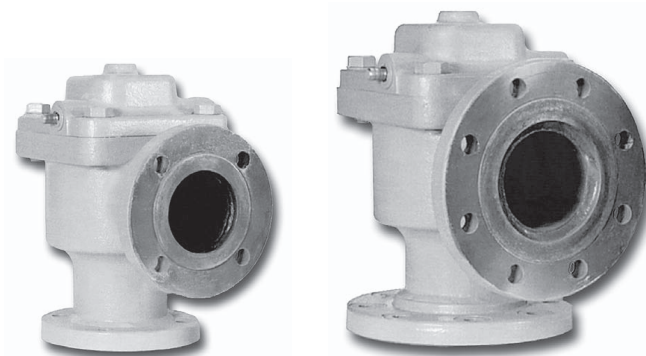

Figure 14: VS-3 & VS-4 Valves

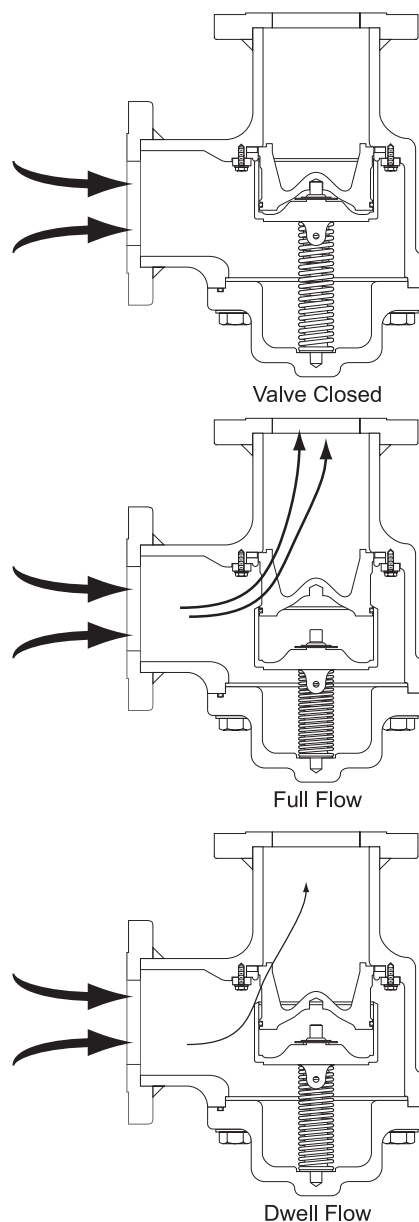

Figure 15: Valve Function

VS-3 & VS-4 Valves - Installation

Accessories

Flanges

Flanges are offered in 3 and 4 inch BSPT and NPT sizes and weld types. Material of construction is steel. Teflon, Viton, and Buna seals and gaskets are available.

Linkage and Valve Handles

Valve handle and linkage assemblies are accessories used when normal manual ON and OFF valve operation is desired. Different handle and linkage configurations can be ordered separately for field installations.

The VS-3 and VS-4 linkage assemblies come complete with a handle. The available Linkage Assemblies for VS-3 and VS-4 valves are listed in the table below.

VS-3 Valve Linkage Assemblies		
Part Number	Style	Description
A3730	Offset	For use with M-15 through M-60 & MS-15 through MS-40
A5712	Offset	For use with M-60 and MS-30 without a Counter Extension

VS-4 Valve Linkage Assemblies		
Part Number	Style	Description
A4710	Offset	Linkage Assembly for LC Preset

Installation

New Installations

When ordered with a new metering system, the VS-3 or VS-4 Series Valve is supplied mounted to the outlet side of the meter as shown in Figure 16. A liquid line must be connected to the flange on the outlet side of the valve or to the accompanying check valve as shown in the figure to the right. The flange connection on the VS-3 valve is 3" BSPT or NPT. The flange connection on the VS-4 valve is 4" BSPT or NPT. Weld-type flangers are available as an option.

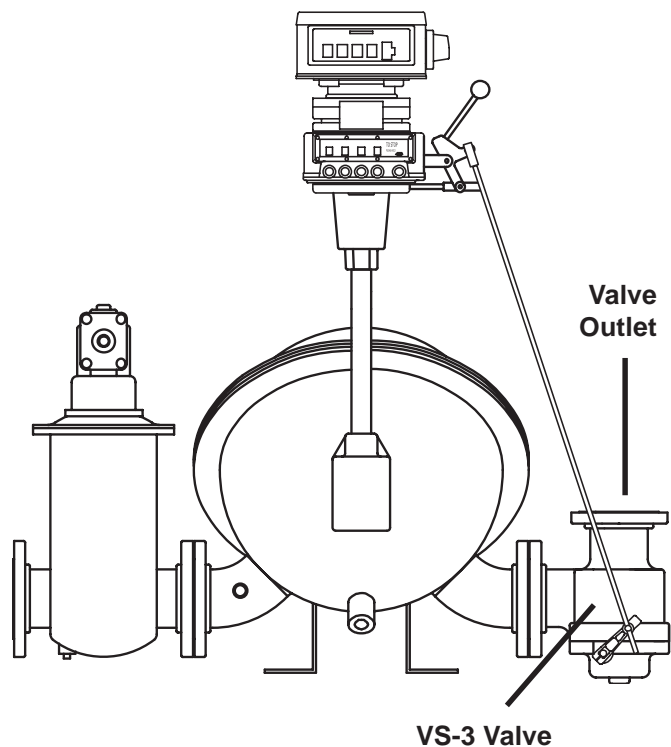

Figure 16: VS Valve Installed

Retrofit Installations

⚠ WARNING

Relieve Internal Pressure

All internal pressure must be relieved to zero pressure before disassembly or inspection of the meter or any of the meter accessories.

Serious injury or death from fire or explosion could result from maintenance of an improperly depressurized and evacuated system.

Depending on the existing configuration, adding a VS-3 or VS-4 Valve may require modification of the outlet piping.

After the internal pressure is relieved from the system, drain all the fluid from the flowmeter and accessories. The outlet line can then be disconnected from the flowmeter.

Installing the Valve

The VS-3 or VS-4 valve is installed on the outlet side of the flowmeter. The valve may be installed in one of four orientations. Determine the orientation desired and then attach the flowmeter using the four bolts and washers provided. Tighten the bolts in a crossing pattern.

Installing the Linkage Assembly

The handle and linkage assembly is provided with the VS-3 and VS-4 Valves. The handle and linkage may need to be repositioned depending on the valve orientation.

The valve handle mounts on either side of the valve shaft. Mount the valve handle to the valve shaft and tighten the handle screw. With the handle securely mounted to the valve shaft, the linkage assembly can be connected to the preset ring under the mechanical register.

The linkage assembly connects to the preset ring via the ball joint extension (Figure 17a). The ball joint extension is mounted using the screw and nut provided.

Mount the ball joint extension to the preset ring by threading the screw into one of the holes at the back of the register assembly. Thread the nut in place on the screw.

With the ball joint extension secure on the preset ring, attach the linkage assembly (Figure 17b). The linkage assembly may require adjustment in order to mount to the ball joint extension. If this is the case, either loosen the handle and reposition on the valve shaft, or loosen the nuts at the handle pivot (Figure 17c).

Once the handle and linkage assembly is secure, proceed with setting the dwell and zero shut-off as described on Pages 9-10.

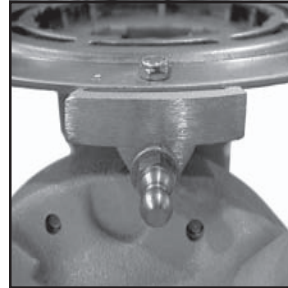

Figure 17a: Ball Joint

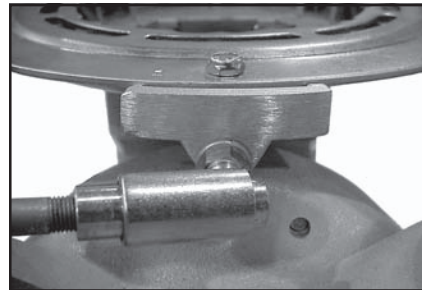

Figure 17b: Linkage Attached to Ball Joint

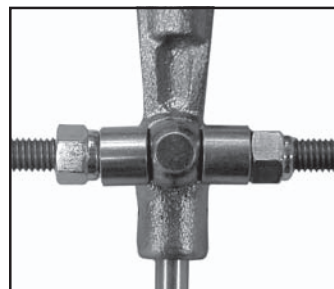

Figure 17c: Handle Pivot

VS-3 & VS-4 Valves - Disassembling

Disassembling the Valve

The VS-3 & VS-4 Valves are under pressure from the compression spring. The safest method for opening the valve for service or maintenance is to place the valve on a flat surface with the valve outlet facing down.

1. Loosen the four bolts (Item 611) located on the valve cap (Item 124). The compression spring will exert a force on the cap and push it up.
2. When the four bolts are almost completely removed, check to see if the compression spring is still exerting a force on the cap. If not, remove the four bolts and washers completely. If there is still force on the cap, remove two screws from opposite sides of the cap. While bracing the cap with one hand, remove the other two bolts and carefully release the cap until the compression spring exerts no force.
3. Note the orientation of the cap and valve handle. Remove the cap (Item 124). The internal components are attached to the cap and will come out of the valve housing with the cap.
4. To disassemble the cap assembly, it will be necessary to remove the four cotter pins which hold the cup (Item 133) to the links on each side of the cup. This is only necessary when replacing the compression spring or the cup.
5. To replace the dashpot washer (Item 727), remove the retaining ring (Item 559) from the end of the guide shaft.
6. Four screws (Item 627) and lock washers (Item 745) secure the guide (Item 138) and seals in place. These screws are accessed from the opening created when the cap (Item 124) and components were removed. Remove these four screws and washers to inspect and replace components as necessary.

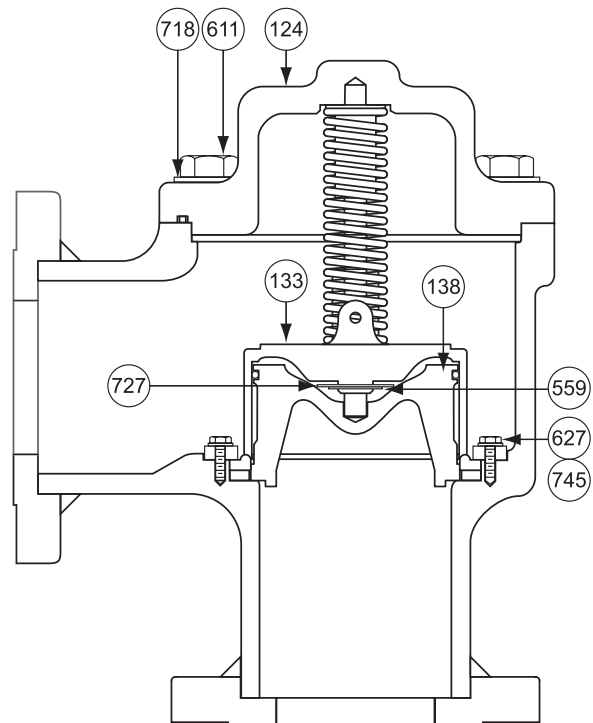

Figure 18: VS-3 Valve

The valve shaft (Item 368) is very difficult to remove, but it is not necessary to remove it in order to inspect or replace the O-Rings and bearings of the valve shaft.

7. Remove the retaining ring (Item 564) from one side of the valve shaft.
8. Remove the shaft seal (Item 270), the bearing (Item 140) the O-Ring (Item 456), the inner bearing (Item 260) and the O-Ring (Item 451).
9. Inspect and replace these components as needed.
10. Repeat steps 7-9 for the other side of the valve shaft.

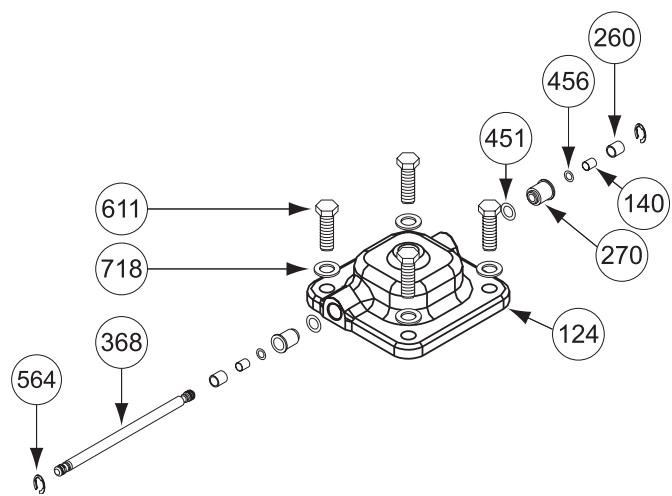

Figure 19: VS-3 Cap Assembly

Reassembling the Valve

For reassembly, refer to Figures 18 & 19 or the parts breakdown on Pages 21 & 23.

1. Place the O-Ring (Item 455) on the guide (Item 354).
2. Place the upper seal (Item 453) and the bonded seal ring (Item 354) onto the guide (Item 138).
3. Place the two retainer ring guides (Item 139) on the guide.
4. Place the guide (Item 138) into the valve.
5. Secure this assembly using the four screws (Items 627) and lock washers (Item 745).
6. Reassemble the valve by placing the dashpot washer and retaining ring on the end of the guide shaft.
7. Place the complete cap assembly on the valve housing remembering to orient the valve handle in the same position as it was prior to disassembling.
8. Insert the four screws and washers into the valve cap and tighten by alternately tightening each screw a few turns so that the cup (Item 133) slides evenly over the guide (Item 138).
9. When the cap rests against the valve housing evenly, tighten all four screws in a crossing pattern.
10. If the valve shaft components were removed for inspection or replacement, reassemble the valve shaft components following the drawing to the right.
11. Insert the O-Ring (Item 451), the Inner bearing (Item 260), the next O-Ring (Item 456), the next bearing (Item 140), the shaft case seal (Item 270) and secure with the retaining ring (Item 564).

This completes reassembly. The valve may be placed back in service. Be sure to check for leaks. Refer to Pages 12 & 13 for installation instructions.

Illustrated Parts Breakdown - V-15 Valves

<u>Item No.</u>	<u>Description</u>	<u>Part No.</u>
110	Housing	40731
124	Valve Cap	43985
133	Cup	43529
138	Guide	43953
140	Bearing (2)	09050
260	Inner Bearing (2)	47889
270	Shaft Case Seal (2)	47891
337	Link (2)	43534
338	Link Arm	43533
354	Seal Ring	40736
368	Valve Shaft	40746
370	Guide Shaft	40737
382	Compression Spring	40735
412	Cap Casket	40738
424	Flange Gasket	40871
450	O-Ring (2)	09046
455	O-Ring (2)	09311
465	Upper Seal Ring	40742
541	Cotter Pin (4)	04005
543	Tapered Groove Pin	06822
559	Retaining Ring	04001
564	Retaining Ring (2)	04003
610	Screw, .500-13 x 1.50 (2)	06057
611	Screw, .500-13 x 2.25 (2)	00244
615	Screw, #10-24 x .375 (2)	06819
626	Screw, .500-13 x 1.50 (4)	06057
718	Flat Washer (8)	04685
727	Dashpot Washer	40944
741	Flat Washer (4)	06818

<u>Model No.</u>	<u>A3610</u>	<u>A3611</u>	<u>A3612</u>	<u>A3620</u>	<u>A3622</u>	<u>A3624</u>
<u>Item No.</u>	<u>Part No.</u>					
110	40731	40731	40731	40731	40731	40731
124	43985	43985	43985	43985	43985	43985
133	43529	43998	43529	43529	43529	43529
138	43953	43953	43978	43953	43978	43953
140	09050	09050	09050	09050	09050	09050
260	47889	47889	47889	47889	47889	47889
270	47891	47891	47891	47891	47891	47891
337	43534	43534	43534	43534	43534	43534
338	43533	43533	43533	43533	43533	43533
354	40736	40736	43982	40736	43982	40736
368	40746	40746	40746	40746	40746	40746
370	40737	40737	40737	40737	40737	40737
382	40735	40735	40735	43535	43535	43535
412	40738	46070	40738	46070	40738	40738
424	40871	46069	40871	N/A	40871	40871
450	09046	09046	09047	09046	09047	09046
455	09311	09311	09045	09311	09045	09311
465	40742	40742	07209	40742	07209	40742
541	04005	04005	04005	06936	06936	06936
543	06822	06822	06822	06822	06822	06822
559	04001	N/A	04001	06820	06820	06820
564	04003	04003	04003	06821	06821	06821
572	N/A	N/A	07207	N/A	07207	N/A
610	06057	06057	06057	06057	06057	06057
611	00244	00244	00244	00244	00244	00244
615	06819	06819	06819	06819	06819	06819
626	06057	06057	06057	06057	06057	06057
718	04685	04685	04685	04685	04685	04685
727	40944	N/A	43521	43521	43521	43521
741	06818	06818	06818	06818	06818	06818

*N/S = Not for Sale

Illustrated Parts Breakdown - V-15 Valves

A-3610 Shown

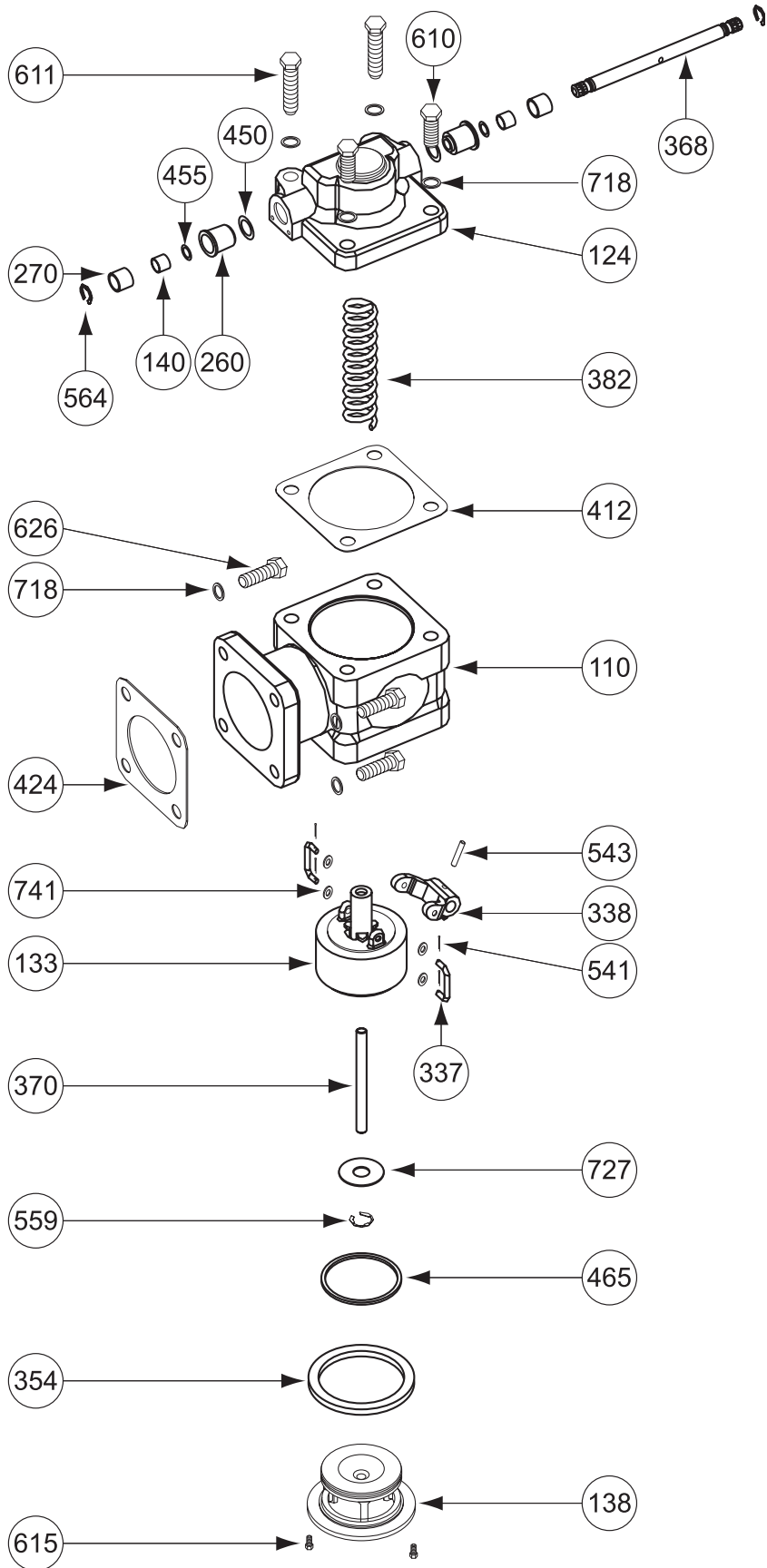

Illustrated Parts Breakdown - V-30 Valves

Item No.	Description	Part No.
110	Housing Sub-Assembly	40931
124	Valve Cap	43976
133	Cup	43528
138	Guide	43956
140	Bearing (2)	09050
260	Inner Bearing Guide (2)	47889
270	Shaft Case Seal (2)	47892
337	Link (2)	43525
338	Link Arm	43524
354	Seal Ring	46239
368	Valve Shaft	40987
370	Guide Shaft	40967
382	Compression Spring	40942
412	Flange Gasket (2)	40704
450	O-Ring (2)	09048
455	O-Ring (2)	09311
465	Upper Seal Ring	40969
541	Cotter Pin (4)	04005
543	Tapered Groove Pin	06822
559	Retaining Ring	04001
564	Retaining Ring (2)	04003
610	Screw, .625-11 x 1.75 (6)	04762
611	Screw, .625-11 x 2.50 (2)	06466
615	Screw, #10-24 x .375 (2)	06819
718	Flat Washer (8)	04764
727	Dashpot Washer	40944
741	Flat Washer (4)	06818

Model No.	A4610	A4611	A4612	A4622A	A4623	A4624
Item No.	Part No.					
110	40931	40931	40931	40931	40931	40931
124	43976	43976	43976	43976	43976	43976
133	43528	43734	43528	43528	43528	43528
138	43956	43956	43979	43979	43956	43956
140	09050	09050	09050	09050	09050	09050
260	47889	47889	47889	47889	47889	47889
270	47892	47892	47892	47892	47892	47892
337	43525	43525	43525	43525	43525	43525
338	43524	43524	43524	43524	43524	43524
354	46239	46239	43981	43981	46239	46239
368	40987	40987	40987	40987	40987	40987
370	40967	40967	40967	40967	40967	40967
382	40942	43526	40942	43526	43526	43526
412	40704	46072	40704	40704	46072	40704
450	09048	09048	09049	09049	09048	09048
455	09311	09311	09045	09045	09311	09311
465	40969	40969	07202	07202	40969	40969
541	04005	06936	04005	06936	06936	06936
543	06822	06822	06822	06822	06822	06822
559	04001	N/A	04001	06820	06820	06820
564	04003	06821	04003	06821	06821	06821
572	N/A	N/A	07203	07203	N/A	N/A
610	04762	04762	04762	04762	04762	04762
611	06466	06466	06466	06466	06466	06466
615	06819	06819	06819	06819	06819	06819
626	N/A	N/A	N/A	N/A	04762	04762
718	04764	04764	04764	04764	04764	04764
727	40944	N/A	40944	43521	43521	43521
741	06818	06818	06818	06818	06818	06818

*N/S = Not for Sale

Illustrated Parts Breakdown - V-30 Valves

A-4610 Shown

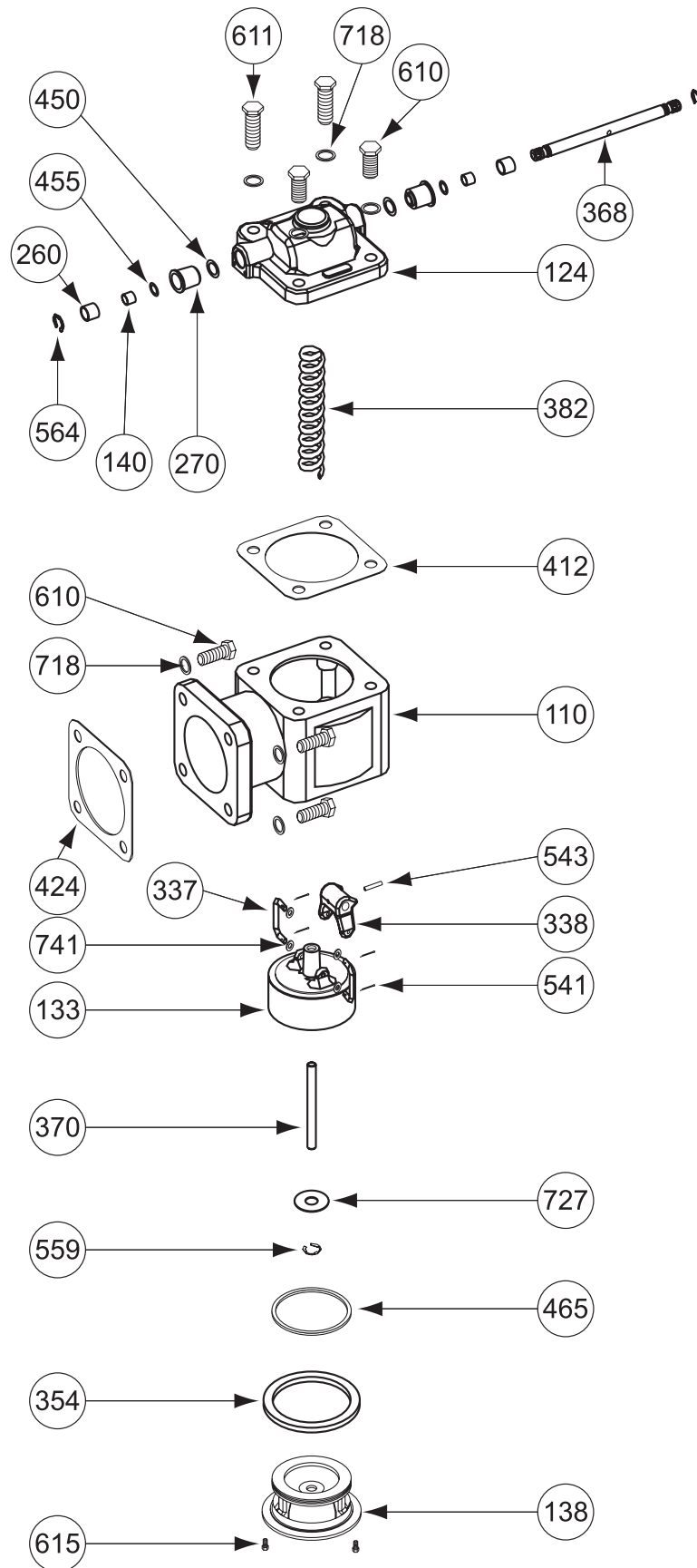

Illustrated Parts Breakdown - VS-3 Valves

<u>Item No.</u>	<u>Description</u>	<u>Part No.</u>	<u>Item No.</u>	<u>Description</u>	<u>Part No.</u>
110	Housing Sub-Assembly	N/S*	453	Upper Seal Ring	40969
124	Cap Sub-Assembly	45533	455	O-Ring	07611
133	Cup	43528	456	O-Ring (2)	09311
138	Machined Guide	45530	533	Nut, .625-11 (4)	07212
139	Retainer Ring Guide (2)	45521	541	Cotter Pin (4)	04005
140	Bearing (2)	09050	543	Tapered Groove Pin	06822
260	Inner Bearing Guide (2)	47890	559	Retaining Ring	04001
270	Shaft Case Seal (2)	47893	564	Retaining Ring (2)	04003
337	Link (2)	43525	611	Screw, .750-10 x 2.25 (4)	07255
338	Link Arm	43524	614	Screw, .625-11 x 2.75 (4)	07293
354	Seal Ring	46239	627	Screw, .250-20 x .625 (4)	07613
368	Cap Shaft	45507	650	Stud, Nut, Gasket Kit	45241
370	Guide Shaft	40967	718	Flat Washer (4)	07256
382	Compression Spring	40942	727	Dashpot Washer	40944
420	Flange Gasket	07261	741	Flat Washer (4)	04789
450	O-Ring	07504	745	Lock Washer (4)	06174
451	O-Ring (2)	09048			

<u>Model No.</u>	<u>A36501</u>	<u>A36502</u>	<u>A36521</u>	<u>A36522</u>	<u>A36551</u>	<u>A36552</u>	<u>A36572</u>	<u>A36582</u>
<u>Item No.</u>	<u>Part No.</u>							
110	N/S*	N/S	N/S	N/S	N/S	N/S	N/S	N/S
124	45533	45533	45533	45533	45533	45533	45533	45533
133	43528	45528	43528	45528	43528	45528	45528	45528
138	45530	45529	N/S*	45526	45530	45529	45529	45526
139	45521	45521	45521	45521	45521	45521	45521	45521
140	09050	09050	09050	09050	09050	09050	09050	09050
260	47890	47890	47890	47890	47890	47890	47890	47890
270	47893	47893	47893	47893	47893	47893	47893	47893
337	43525	43525	43525	43525	43525	43525	43525	43525
338	43524	45531	43524	45531	43524	45531	45531	45531
354	46239	46239	43981	43981	46239	46239	46239	43981
368	45507	45507	45507	45507	45507	45507	45507	45507
370	40967	40967	40967	40967	40967	40967	40967	40967
382	40942	40942	40942	40942	40942	40942	40942	40942
390	N/A	N/A	N/A	N/A	N/A	N/A	N/A	07269
420	07261	07261	07261	07261	07262	07262	07261	07261
450	07504	07504	07608	07608	07504	07504	07504	07608
451	09048	09048	09049	09049	09048	09048	09048	09049
453	40969	40969	07202	07202	40969	40969	40969	07202
455	07611	07611	07612	07612	07611	07611	07611	07612
456	09311	09311	09045	09045	09311	09311	09311	09045
533	07212	07212	07212	07212	06985	06985	07212	07212
541	04005	04005	04005	04005	04005	04005	04005	04005
543	06822	06822	06822	06822	06822	06822	06822	06822
559	04001	04001	04001	04001	04001	04001	04001	04001
564	04003	04003	04003	04003	04003	04003	04003	04003
572	N/A	N/A	07203	07203	N/A	N/A	N/A	07203
611	07255	07255	07255	07255	07255	07255	07255	07255
614	07293	07293	07293	07293	N/S	N/S	07293	07293
627	07613	07613	07613	07613	07613	07613	07613	07613
650	45241	45241	45241	45241	45242	45242	45249	45249
718	07256	07256	07256	07256	07256	07256	07256	07256
727	40944	40944	40944	40944	40944	40944	40944	40944
741	04789	04789	04789	04789	04789	04789	04789	04789
745	06174	06174	06174	06174	06174	06174	06174	06174

*N/S = Not for Sale

Illustrated Parts Breakdown - VS-3 Valves

A-36501 Shown

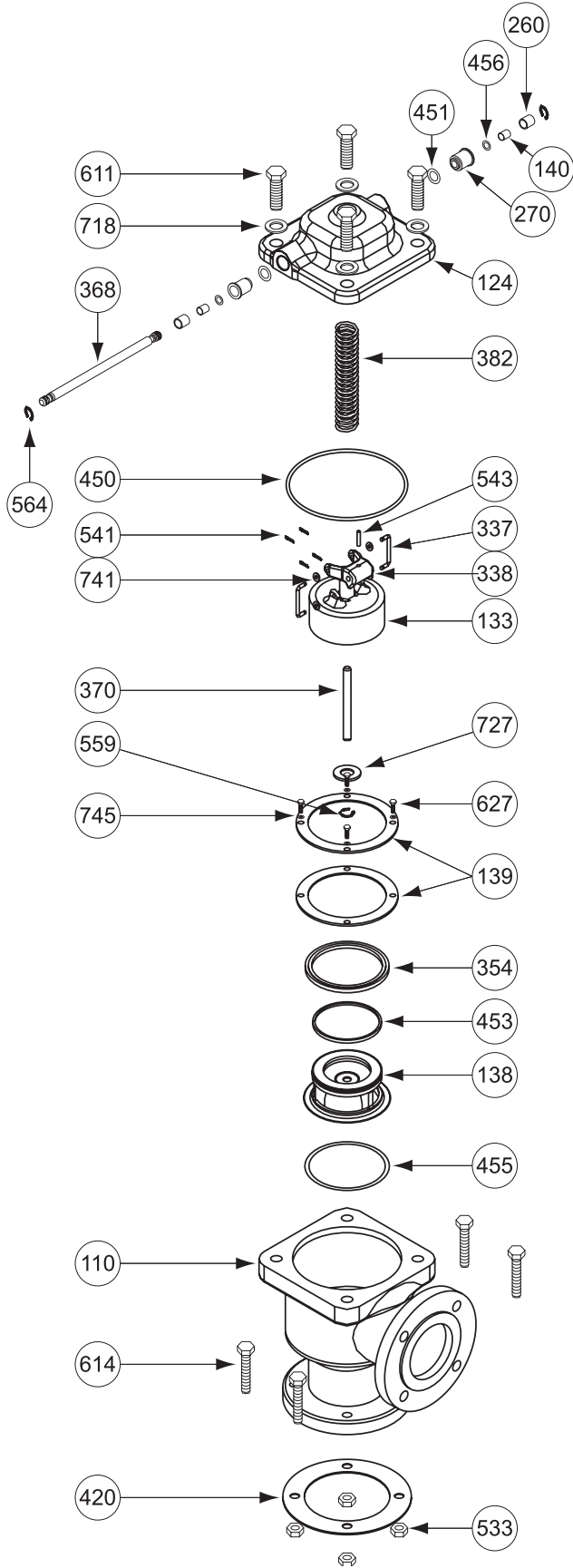

Illustrated Parts Breakdown - VS-4 Valves

Item No.	Description	Part No.
110	Housing Sub-Assembly	N/S*
124	Cap Sub-Assembly	45533
133	Cup	43528
138	Machined Guide	45530
139	Retainer Ring Guide (2)	45521
140	Bearing (2)	09050
260	Inner Bearing Guide (2)	47890
270	Shaft Case Seal (2)	47893
337	Link (2)	43525
338	Link Arm	43524
354	Seal Ring	46239
368	Cap Shaft	45507
370	Shaft Guide	40967
382	Compression Spring	40942
420	Flange Gasket	07263
450	O-Ring	07504
451	O-Ring (2)	09048
453	Upper Seal Ring	40969
455	O-Ring	07611
456	O-Ring (2)	09311
533	Nut, .625-11 (8)	07212
541	Cotter Pin (4)	04005
543	Tapered Groove Pin	06822
559	Retaining Ring	04001
564	Retaining Ring (2)	04003
611	Screw, .750-10 x 2.25 (4)	07255
614	Screw, .625-11 x 2.75 (8)	07293
627	Screw, .250-20 x .625 (4)	07613
650	Stud, Nut, Gasket Kit	45248
718	Flat Washer (4)	07256
727	Dashpot Washer	40944
741	Flat Washer (4)	04789
745	Lock Washer (4)	06174

Model No.	A46501	A46502	A46521	A46522	A46551	A46522
Item No.	Part No.					
110	N/S*	N/S	N/S	N/S	45524	45524
124	45533	45533	45533	45533	45533	45533
133	43528	45528	43528	45528	43528	45528
138	45530	45529	45527	45526	45530	45529
139	45521	45521	45521	45521	45521	45521
140	09050	09050	09050	09050	09050	09050
260	47890	47890	47890	47890	47890	47890
270	47893	47893	47893	47893	47893	47893
337	43525	43525	43525	43525	43525	43525
338	43524	45531	43524	45531	43524	45531
354	46239	46239	43981	43981	46239	46239
368	45507	45507	45507	45507	45507	45507
370	40967	40967	40967	40967	40967	40967
382	40942	40942	40942	40942	40942	40942
420	07263	07263	07263	07263	N/S	N/S
450	07504	07504	07608	07608	07504	07504
451	09048	09048	09049	09049	09048	09048
453	40969	40969	07202	07202	40969	40969
455	07611	07611	07612	07612	07611	07611
456	09311	09311	09045	09311	09311	09311
533	07212	07212	07212	07212	06985	06985
541	04005	04005	04005	04005	04005	04005
543	06822	06822	06822	06822	06822	06822
559	04001	04001	04001	04001	04001	04001
564	04003	04003	04003	04003	04003	04003
572	N/A	N/A	07203	07203	N/A	N/A
611	07255	07255	07255	07255	07255	07255
614	07293	07293	07293	07293	N/S	N/S
627	07613	07613	07613	07613	07613	07613
650	45248	45248	45248	45248	45243	45243
718	07256	07256	07256	07256	07256	07256
727	40944	40944	40944	40944	40944	40944
741	04789	04789	04789	04789	04789	04789
745	06174	06174	06174	06174	06174	06174

*N/S = Not for Sale

Illustrated Parts Breakdown - VS-4 Valves

A-46501 Shown

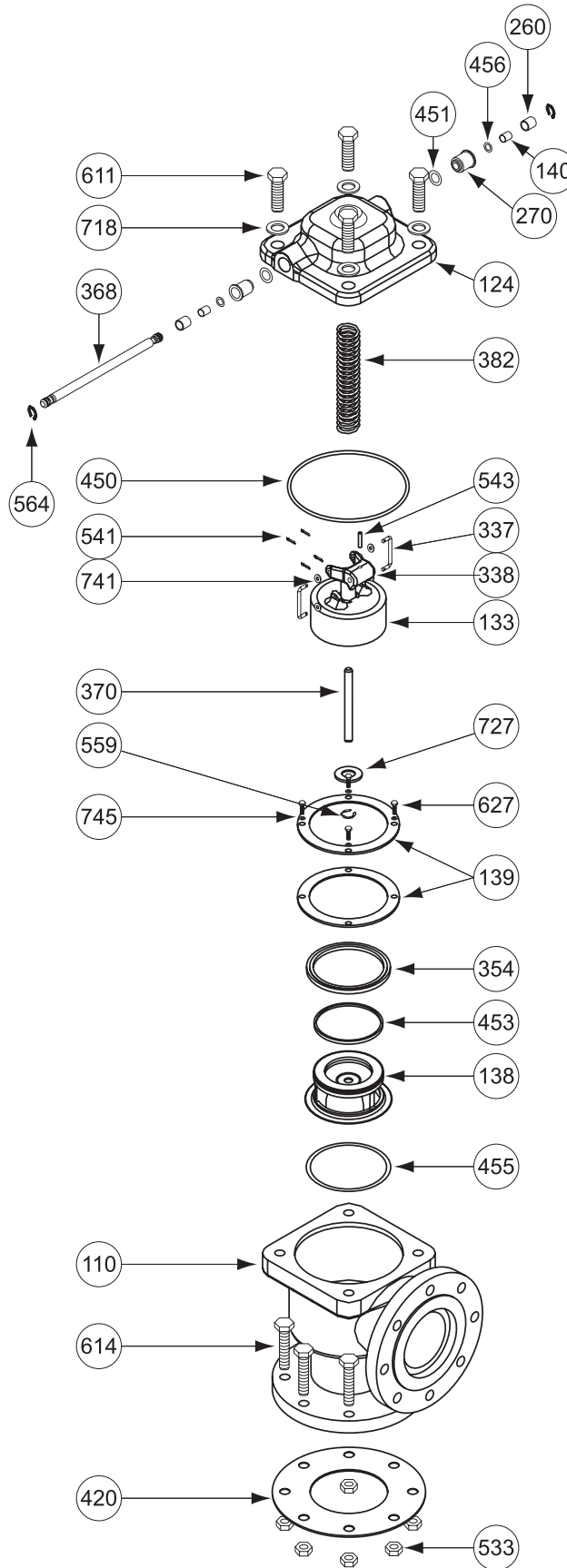



**Backed by our Worldwide reputation for
Quality, Accuracy and Advanced Design.**



LIQUID CONTROLS

A Unit of IDEX Corporation
105 Albrecht Drive
Lake Bluff, IL 60044-2242
1.800.458.5262 • 847.295.1050
Fax: 847.295.1057
www.lcmeter.com

© 2007 Liquid Controls
Pub. No. 48854B
(02/07)

