



# LectroCount LCR-II<sup>®</sup> Installation

## E3655/E3656 Series



# Table des matières

---

Introduction	Nomenclature
Procédures de sécurité ..... 3	Composants externes..... 34
Protection ESD..... 4	Composants internes..... 35
Spécifications ..... 5	Carte processeur..... 35
Dimensions..... 6	
Aperçu du LectroCount LCR-II..... 7	
Aperçu du système de comptage..... 8	
Installation	
Aperçu de l'installation..... 10 Kit	
de bracelet de terre LectroCount..... 12	
Montage du LectroCount LCR-II ..... 14	
Câblage des câbles de données et d'alimentation LCR-II ..... 17	
Compensation électronique de volume par température..... 18	
Vannes..... 19	
Éliminateurs optiques d'air et de vapeur..... 24	
Dispositif à sortie impulsionnelle (POD)..... 25	
Capteur de pression différentielle ( $\Delta P$ )..... 26	
Affichage distant et sorties auxiliaires..... 27	
Imprimantes..... 28	
Communications de données..... 29	
Installation électrique..... 30	
Post-installation..... 33	

## Mises à jour et traductions des publications

Les versions anglaises les plus récentes de toutes les publications de Liquid Controls sont disponibles sur notre site web, **www.lcmeter.com**. Il est de la responsabilité du distributeur local de fournir la version la plus récente des manuels, instructions et fiches techniques LC dans la langue requise du pays, ou dans la langue de l'utilisateur final vers lequel les produits sont expédiés. En cas de question concernant la langue des manuels, instructions ou fiches techniques LC, veuillez contacter votre distributeur local.

## Soyez préparé

### ! AVERTISSEMENT

- Avant d'utiliser ce produit, lisez et comprenez les instructions. • Tous les travaux doivent être effectués par du personnel qualifié formé à l'application, l'installation et la maintenance des équipements et/ou systèmes conformément à tous les codes et règlements applicables.
- Lors de la manipulation de composants et cartes électroniques, utilisez toujours un équipement de protection contre les décharges électrostatiques (ESD) et suivez les procédures appropriées.
- Assurez-vous que toutes les précautions de sécurité nécessaires ont été prises. • Prévoir une ventilation adéquate, un contrôle de la température, une prévention des incendies, une évacuation et une gestion des incendies. • Assurez un accès facile aux extincteurs appropriés pour votre produit. • Consultez votre service d'incendie local ainsi que les codes étatiques et locaux pour assurer une préparation adéquate. • Lisez ce manuel ainsi que toute la documentation fournie dans votre dossier propriétaire. • Conservez ces instructions pour référence future. • Le non-respect des instructions énoncées dans cette publication pourrait entraîner des dommages matériels, des blessures corporelles ou la mort par incendie et/ou explosion, ou d'autres dangers pouvant être associés à ce type d'équipement.

## Évacuation sécuritaire Système de tuyauterie

### ! AVERTISSEMENT

**AVERTISSEMENT : Risque d'explosion - NE PAS débrancher l'équipement à moins que l'alimentation ne soit COUPÉE ou que la zone ne soit reconnue comme non dangereuse. Avant le démontage de tout compteur ou composant accessoire, LE SYSTEME CONFORME À TOUTES LES PROCEDURES APPLICABLES.**

- La pression doit être de 0 (zéro) psi.
- Fermer toutes les conduites de liquide et de vapeur entre le compteur et la source de liquide.

Pour les règles de sécurité concernant le GPL, se référer à la brochure NFPA 58 et aux autorités locales.

Le non-respect de cet avertissement pourrait entraîner des dommages matériels, des blessures corporelles ou la mort par incendie et/ou explosion, ou d'autres risques pouvant être associés à ce type d'équipement.

## Respecter les codes nationaux et locaux

Le câblage d'alimentation, d'entrée et de sortie (E/S) doit être conforme à la classification de zone pour laquelle il est utilisé (Classe I, Div 2). Pour l'Amérique du Nord, les installations doivent être conformes au Code électrique national des États-Unis, NFPA 70, ou au Code électrique canadien afin de maintenir les classements Classe I, Division 2. Cela peut nécessiter l'utilisation de connexions ou d'autres adaptations conformes aux exigences de l'autorité compétente.

### AVERTISSEMENT : Risque d'explosion -

Le remplacement de composants peut compromettre l'aptitude aux applications Classe I, Division 2.

### AVERTISSEMENT : Risque d'explosion -

En environnements dangereux, COUPER l'alimentation AVANT de remplacer ou de câbler les modules.

# ESD Protection

---

## Dommages potentiels causés par l'exposition aux décharges électrostatiques (ESD)

Pour prévenir les dommages causés par les décharges électrostatiques (ESD) aux composants électroniques des enregistreurs LectroCount, toutes les installations d'enregistreurs électroniques LectroCount sur camion doivent inclure la mise à la terre correcte des coussins de siège(s) et des imprimantes Epson. Une exposition prolongée aux ESD sur des semaines, des mois ou des années peut corrompre la mémoire CPU des enregistreurs LectroCount et endommager les composants électroniques des enregistreurs LectroCount (ainsi que d'autres composants électriques du système électrique du camion).

Les sièges réglables et absorbant les chocs, s'ils ne sont pas correctement mis à la terre, génèrent des quantités importantes d'ESD. Les pivots et les charnières de ces sièges isolent le coussin de siège de la masse électrique. Sans mise à la terre électrique, l'ESD s'accumule entre le coussin de siège et l'opérateur. Cette ESD accumulée peut être transférée vers l'enregistreur LectroCount à partir de n'importe quel point du système électrique du camion, tel que le câblage de l'enregistreur LectroCount à la cabine ou l'imprimante Epson.

## Kits de mise à la terre Liquid Controls

Pour protéger les composants électroniques contre les ESD, toutes les installations de camion LectroCount doivent inclure l'installation du kit de sangle de terre LectroCount (réf. 82185) et du kit de fil de terre pour imprimante Epson (réf. 82184). Des sièges correctement mis à la terre permettent à l'électricité statique de se 'dissiper' du conducteur et du siège avant qu'elle ne puisse s'accumuler, se décharger et endommager l'enregistreur LectroCount ou tout autre composant électrique du camion.

Le kit de sangle de terre LectroCount sera inclus dans toutes les futures expéditions d'enregistreurs LectroCount LCR-II, et le kit de fil de terre pour imprimante Epson sera inclus dans toutes les futures expéditions de kits de câbles d'imprimante Epson. Les numéros de pièce concernés sont listés ci-dessous. Pour les installations existantes et les enregistreurs LectroCount et imprimantes Epson précédemment achetés, les deux kits de mise à la terre sont disponibles auprès de LC.

## Précautions procédurales ESD et mise à la terre du registre LectroCount

### Notes d'installation

Lors de l'installation ou de la maintenance d'un registre LectroCount, certaines directives doivent être suivies pour se protéger contre les dommages ESD.

**Registres non montés directement sur le compteur** Dans les installations LectroCount typiques où le registre LectroCount est monté directement sur le compteur, le boîtier LectroCount est mis à la terre via le compteur. Si le registre n'est pas monté sur le compteur, vous devez vous assurer que le boîtier LectroCount est correctement mis à la terre.

#### Méthode de mise à la terre alternative

Connectez la vis de terre verte (à l'intérieur du boîtier LectroCount dans le coin supérieur droit) à une bonne prise de terre connue (moins de 1 ohm). Utilisez un fil toronné de calibre 12 ou plus.

**Installations fixes** Les boîtiers LectroCount montés directement sur le compteur sont connectés à la terre via le compteur, la cuve et la tuyauterie de la cuve, qui sont mis à la terre par les prises de terre du système électrique. Les installations fixes de Division 1 nécessitent généralement un conduit métallique jusqu'aux raccords de conduit pour le câblage. Le conduit métallique fournit la protection ESD nécessaire. Les installations de Division 2 peuvent mettre à la terre le boîtier LectroCount en utilisant des câbles blindés (ou câblage) passant dans du liquidtight (revêtu de métal/caoutchouc). Le liquidtight et ses connecteurs fournissent la protection ESD nécessaire. Les installations fixes AC nécessitent une méthode de mise à la terre supplémentaire pour assurer une terre correcte.

#### Méthode alternative de mise à la terre pour installations fixes CA

Connectez la vis de terre verte (à l'intérieur du boîtier LectroCount dans le coin supérieur droit) à une bonne prise de terre connue (moins de 1 ohm). Utilisez un fil toronné de calibre 12 AWG ou plus.

### Précautions contre l'ESD Ouverture des terminaux LectroCount

**Suivez cette procédure chaque fois que vous ouvrez un terminal LectroCount ou que vous approchez d'un terminal LectroCount avec la porte ouverte.**

*Avant d'ouvrir le terminal LectroCount et de manipuler la carte CPU, il est important de décharger toute électricité statique (ESD) qui aurait pu s'accumuler sur votre personne. Pour décharger l'électricité statique de votre corps, touchez un point bien mis à la terre tel que le boîtier du terminal LectroCount, le compteur, la tuyauterie du camion, ou le pare-chocs. Lorsque la maintenance est terminée et que la porte du terminal LectroCount est fermée, la carte CPU est protégée contre l'ESD par le boîtier du terminal LectroCount qui est mis à la terre sur le châssis.*

## Mécanique

### Matériaux de construction

- Aluminum Alloy ADC12
- Powder Coat: Corro-Coat PE 74-141 Polyester

### Poids

- 8.4 lbs (3.8 kg)

### Éléments d'affichage

- Liquid crystal display (LCD)

### Entrées de câble

- 1/2" NPT (5)
- 3/4" NPT (2)

### Plage de température

- -40 à 158 °F (-40 à 70 °C)

## Électrique

### Tension d'entrée

Tension : 9 à 28 VCC

Courant maximum : 4,5 A max

(y compris les électrovannes)

### Sortie d'impulsions

Tension crête à crête : 5 à 28 V

Fréquence maximale : 7500 Hz

### Sortie d'impulsion d'échelle

Capacité de puits de courant : 150 mA

### Protection électrique

- Fusible 7,5 A

## Entrée/Sortie

### Communications

- RS-232 : norme EIA-232E
- RS-485 : norme SAE J1708

### Sortie auxiliaire 1

Capacité de puits de courant : 1 A

### Sortie auxiliaire 2

Capacité de puits de courant : 150 mA

### Sortie solénoïde 1

Tension : 10,2 à 27,2 VCC

Courant maximum : 1 A

### Sortie solénoïde 2

Tension : 10,2 à 27,2 VCC

Courant maximum : 1 A

### Sortie solénoïde 3

Tension : 10,2 à 27,2 VCC

Courant maximum : 1 A

### Capteur optique

Tension : 10 à 28 VCC

Courant maximum : 0,5 A max

### Sonde de température RTD

- Capteur platine 4 fils
- 100 Ω de résistance à 0 °C
- 138,5 Ω de résistance à 100 °C

### Imprimante (Modèle Epson 295)

Tension : 24 VCC

Courant maximum : 0,8 A

Température de fonctionnement : -22 à 104 °F (-30 à 40 °C)

### Affichage électronique à distance

- Capacité de puits de 1 A



## Aperçu du LectroCount LCR-II

**Informations générales** Le LectroCount LCR-II de Liquid Controls est un registre de compteur électronique à microprocesseur qui peut être utilisé pour des opérations de transfert de custody approuvées par les Services des Poids et Mesures dans des installations mobiles ou fixes. Le LCR-II peut contrôler un système de compteur en tant qu'unité autonome, ou il peut être utilisé comme esclave d'un contrôleur hôte tel qu'un contrôleur de processus ou un système de gestion de données en cabine.

**Entrées** Afin de calculer les mesures de débit à partir d'un compteur à déplacement positif, le LCR-II reçoit une entrée d'impulsions d'un générateur d'impulsions quadratique monté en interne qui est mécaniquement connecté au débitmètre (des kits de retrofit sont disponibles pour l'installation sur les compteurs à déplacement positif Neptune, Brooks et Smith). Cette sortie d'impulsions peut également provenir d'un générateur d'impulsions POD externe Liquid Controls ou d'un autre générateur d'impulsions. En plus de l'entrée d'impulsions, le LCR-II est équipé d'une entrée pour sonde de température, permettant au registre de compenser les mesures de volume en fonction de la température du produit.

**Sorties** Le LCR-II est équipé d'une sortie d'impulsions mise à l'échelle, deux sorties auxiliaires et deux sorties pour électroaimants. Ces sorties permettent au LCR-II de communiquer avec les accessoires du système de compteur tels que les vannes commandées par électroaimant, les éliminateurs d'air et de vapeur optiques, les affichages distants, les imprimantes et les dispositifs tiers.

### Communications

Le LCR-II peut communiquer via les protocoles RS-232 et RS-485.

**Boîtier** Le boîtier et la base du LectroCount LCR-II sont en aluminium moulé sous pression et revêtus par poudrage. La conception à porte articulée permet un accès facile aux connexions internes et dispose d'un dispositif de scellement homologué Métrologie à l'opposé des charnières. Sept orifices usinés, cinq orifices NPT 1/2" et deux orifices NPT 3/4", sont situés à l'arrière du LectroCount LCR-II pour assurer des connexions de câble sécurisées pour tous les dispositifs externes.

### Affichage

L'affichage de 1" est un écran LCD rétroéclairé à six caractères.

**Touches de navigation** Le LCR-II dispose de deux touches de navigation bombées pour effectuer les configurations et fonctions de base. Les touches s'enfoncent et reviennent en position pour offrir une confirmation tactile positive des frappes.

**Sélecteur** Le sélecteur contrôle les fonctions de base d'arrêt, de marche, d'impression et de livraison d'impression par équipe. Pour effectuer les fonctions d'étalonnage, la plaque de protection doit être retirée et le sélecteur doit être positionné sur la position six heures.

### Fonctionnalité et fonctionnement

Les fonctions principales des compteurs LectroCount comprennent :

- Étalonnage (simple et multipoint)
- Transfert de custody Poids et Mesures (livraison de produit et génération de ticket)
- Collecte de données métrologiques
- Pré-réglage par volume
- Sélection multiple de production
- Paramètres de sécurité
- Élimination d'air et de vapeur (avec accessoires appropriés)
- Commande de vanne (avec accessoires appropriés)
- Compensation électronique de volume par température (CETV) (avec accessoires appropriés)

# Meter System Overview

## Composants du Système de Compteur

Meter System A Liquid Controls meter system not only accurately measures product, it also regulates and purifies product flow in order to produce the optimal conditions for measurement. Optimal systems typically include an air/ vapor eliminator, strainer, meter, register, and control valve. The LectroCount LCR-II, a register, serves as the central controller of the meter system. Most components in the meter system are hard wired to the LCR-II via data communication cables. See manual M100-10.



Débitmètre M7 avec enregistreur électronique LectroCount LCR-II, optique  
Éliminateur d'air, filtre haute capacité et vanne E-7

**Air/vapor Eliminators** Air and vapor eliminators sense and remove air or vapor in the piping before it enters the metering system, ensuring that only liquid will pass through the meter for measurement. Mechanical air eliminators do not require a data connection to the LectroCount LCR-II (in LPG applications, they are often plumbed to a 3-way solenoid which is wired to the LectroCount LCR-II). Optical air eliminators use an optical sensor to monitor liquid levels and a solenoid-actuated valve to turn the vapor vent on and off. The optical sensor and the solenoid valve are connected to the LectroCount LCR-II by separate data cables. See manuals M300-20 and M300-21.



Air Mécanique  
Éliminateur et Haute  
Filtre de Grande Capacité



Éliminateur de Vapeur Optique  
LPG and NH 3



Éliminateur d'air optique  
Carburants raffinés

**Valves** Valves control the flow through a metering system. They open the line to initiate custody transfers and close the line to stop custody transfers. Some valves can partially close, slowing the flow rate to a dwell flow on preset deliveries. By slowing the flow rate, valves can lessen the hydraulic shock incurred by the meter system upon shut off and provide accurate preset deliveries. Many valves use solenoid-operated valves that require a hard wired data connection to the LectroCount LCR-II. See manuals M400-11 and M400-40.



Bloc Solénoïde  
Soupa



E-7 Valve

**Electronic Temperature Volume Compensation (ETVC) Kit** In order to perform temperature compensation equations, the LectroCount LCR-II relies on a temperature probe inserted into the strainer housing. Installation directions for the ETVC kit are included in this manual.



ETVC Kit

# Meter System Overview



Epson Slip Printer



Epson Roll Printer



Remote Display



POD Pulser



$\Delta P$  Transducer



DMS i1000



Lap Pad

## Meter System Components

**Lap Pad** The lap pad programs and displays all operational functions of the LectroCount LCR registers. It has a large, tactile, alpha-numeric keyboard and a dual line, backlit display. A 3-terminal lap pad adapter is provided with each lap pad. The adapter provides a junction for the lap pad, the printer, and the LCR printer cable. **LectroCount Remote Display** The 2¼" digits on the Liquid Controls LectroCount Remote Display allow operators to view the register totalizer values from distances of up to 100 feet. Hard wire data communication with the LectroCount LCR-II is required. See manual EM100-13. **Printers** Printers print delivery tickets to provide a physical record of custody transfers. The Epson slip printer is considered the industry standard for many applications. Multi-layered tickets are available to provide proof components in which the LectroCount LCR-II register is installed at a distance from the meter. The POD pulser requires hard wired data communication with the LectroCount LCR-II. See manual EM300-11. an extended time frame.

**Differential Pressure ( $\Delta P$ ) Transducer** The differential pressure transducer, common in aviation applications, monitors the differential pressure (pressure drop) across a full flow fuel monitor/water coalescer. The highest differential pressure reached during the custody transfer will then be printed on the ticket. Using interlocks, the LectroCount LCR-II can shut down a custody transfer if the differential pressure meets a preprogrammed differential pressure shutdown value. The  $\Delta P$  Transducer requires hard wired data communication with the LectroCount LCR-II. See manual EM300-40.

**Data Management Systems** The DMS i1000 is an in-cab computer with a heavy duty lap pad interface. The DMS i1000 streamlines the flow of data between the LCR-II and back office accounting software. The DMS i1000 must be hard wired to the LectroCount LCR-II. See manuals EM200-10 and EM200-11.

# Installation Overview

---

## Installation Overview

If the LectroCount LCR-II was ordered as part of a meter system, it will arrive mounted on the meter and prewired to the ETVC probe, air eliminator, and valve.

Installation overview for LCR-II ordered with meter system:

1. Ground truck seat cushion. Page 12
2. Install meter system onto truck or fixed installation. Refer to meter manual.
3. Run the LCR-II's data and power cable to truck cab or power supply. Page 17
4. Connect any additional components to the LCR-II's CPU board.
5. Mount printer and connect printer data cable. Page 27
6. Connect the LCR-II and the printer to power supply. Page 29
7. Setup and calibrate the LCR-II. Refer to manual EM150-11.

If you are replacing an existing register, you must mount the register onto the meter and make the proper connections to all of the components.

Installation overview for LCR-II ordered without meter system:

1. Ground truck seat cushion. Page 12
2. Mount the LCR-II to the meter. Page 14
3. Run the LCR-II's data and power cable to truck cab or power supply. Page 17
4. Connect all components to the LCR-II's CPU board.
5. Mount printer and connect printer data cable. Page 27
6. Connect the LCR-II and the printer to power supply. Page 29
7. Setup and calibrate the LCR-II. Refer to manual EM100-11.

### Check Each Shipment

*Before installation, check your shipment against the packing list and ensure that no parts are missing. The packing list is inside the red information packet along with the Installation and Operation Manuals.*

### This Manual Includes

*This manual explains and details the mechanical installation of the LectroCount LCR-II and the temperature probe as well as the electrical and data installation of all components that connect to the LCR-II. For additional installation information, refer to the manuals of the other components. All manuals are available at [www.lcmeter.com](http://www.lcmeter.com).*

### Installation Requirements Vary

*Specific installation requirements will vary with the model of the truck, the physical layout of a fixed installation, the configuration of any existing metering equipment, the options selected, and the type of fluid being metered*



# LectroCount Ground Strap Kit

## LectroCount Ground Strap Kit

All seat cushions are grounded in a similar manner. The illustrations on the next page detail the following instructions for grounding three typical types of truck seats.

To ground a truck seat:

1. Identify any adjustable, shock absorbing seat in the truck cab. These seats will typically have pivot points, hinges, or other mechanical design features that make seat adjustments possible.
2. Find an existing screw or hole near the back of the seat frame, close to the cab floor. If a hole or screw does not already exist, drill a 9/32" hole in the seat frame.
3. Attach one end of the ground strap to the seat frame bracket using the lock washer, flat washer and nut provided.
4. Find an existing screw or hole, or drill a 9/32" hole, in the part of the seat frame—above all pivots and adjustments—that is attached directly to the seat cushion. Make sure that there are no intervening pivot points, guides, adjustment mechanisms, etc., which could interfere with the ground path between the seat cushion and the ground strap.
- 4a. If the seat cushion has a wooden base, use a wood screw and washer to attach the strap lug to the bottom of the seat at a point where the seat fabric is attached to the wood. There must be good contact between the seat fabric and ground strap lug.
5. Use the wire ties provided with the kit and tie off the strap so that it doesn't interfere with the movement of the seat and is clear of traffic areas in the cab.
6. Check the strap for a good ground connection (see below).

### . ESD Precaution .

*Install the LectroCount Ground Strap Kit before installing the LectroCount register.*

### Grounded Passenger Seats

*Some truck seats, typically passenger seats, are not adjustable and do not require grounding.*

### Ensure a Good Ground

*Remove any dirt or oxidation from the ground strap contact point. Lock washers should penetrate any paint to ensure a good electrical connection.*

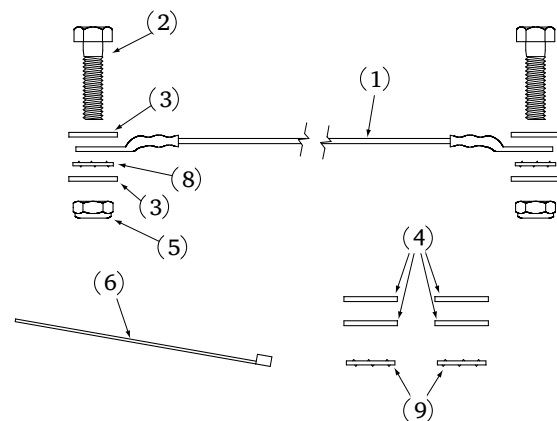

LectroCount Ground Strap Kit - 82185

# Typical Adjustable Truck Seats & Ground Check

## Typical Adjustable Truck Seats

Air Cushion Seat -  
Adjustable for Height  
(Bostrom 914 Series, National 2000 Series, or equivalent)

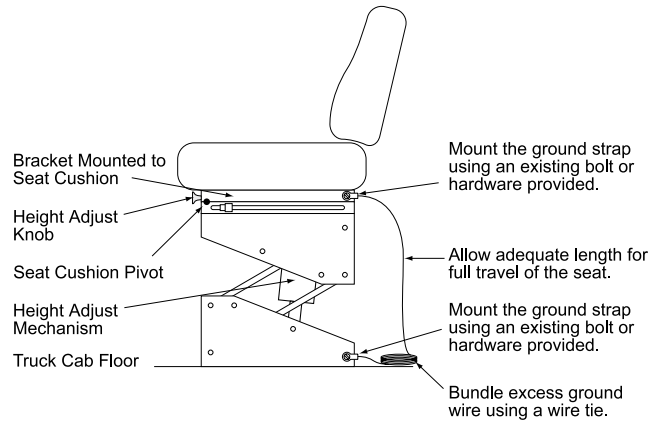

Air Cushion Seat -  
Adjustable for Height  
(Dura-Form or equivalent)

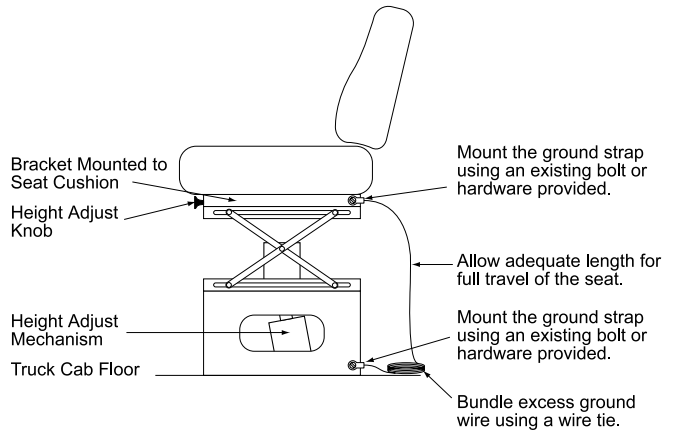

Bench Seats -  
Adjustable for Distance to the Steering Wheel  
(Manufacturer Standard or equivalent)

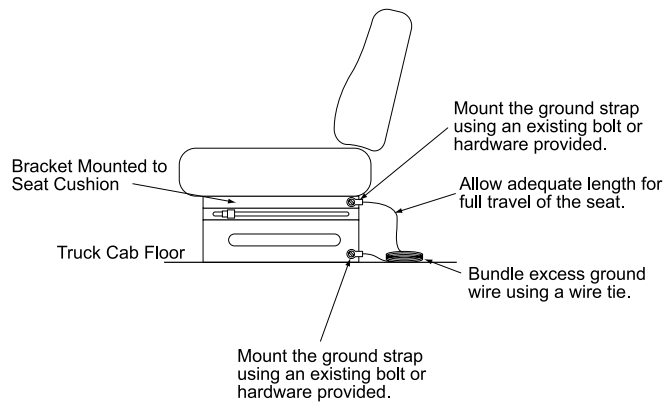

## Checking for a Good Ground

After installing the ground kits, use a multimeter to confirm that the seat and printer are both grounded properly.

To check for a good ground connection:

1. Turn OFF all accessories, including the dome light, to prevent other currents from distorting the reading.
  2. Take a multimeter and measure the resistance between the brackets the two ground strap bolts are fastened to. Find a clean spot on the brackets without paint to use as contact points. Other bolts on the brackets are often suitable.
- 2a. If the resistance is less than  $3\Omega$ , the system is grounded adequately. 2b. If the resistance is still greater than  $3\Omega$ , check for proper metal to metal

contact on both ends of the ground strap. Clean any paint, dirt, or oxidation that may block the grounding point. If the resistance remains above  $3\Omega$ , attach the ground strap to a different ground point. Repeat the process until the ground resistance is below  $3\Omega$ .

### Turn Off Accessories

If the multimeter reads " $M\Omega$ " or " $K\Omega$ ", typically one of the accessories is still on.



LCR-II with LPG  
Meter System



Neptune Adapter



Neptune Coupling



Smith Adapter



Brooks Adapter

## Mounting Overview

Typically, the LectroCount LCR-II is mounted directly onto a flow meter; however, some fixed installations require the register be mounted away from the meter. If the meter is equipped with an external POD pulser, the LCR-II can be mounted up to 1000 wire feet (304 meters) away from the meter (actual distance depends on pulser specifications and wire type).

Adapters are available for other PD meters such as Neptune (PNs 81364, 82641, 82642), FMC Smith (PN 81370), and Brooks/Brodie (PN 81800) meters. Each kit includes installation instructions.

### Tips for mounting an LCR-II :

- Leave the cover assembly fastened to the base to protect the internal components.
- Make sure the vertical drive shaft from the meter is attached to the pulser drive shafts.
- Before securing the LCR-II to the meter or mounting bracket, make sure the counter is visible and the keypad and selector switch can be easily operated.

## ! WARNING

### Relieving Internal Pressure

All internal pressure must be relieved to zero pressure before disassembly or inspection of the strainer, vapor eliminator, any valves in the system, the packing gland, and the front or rear covers.

end of the supply line. **Improperly depressurized and evacuated system.**  
**performing maintenance on an**

#### Relieving Internal Pressure Procedure for LPG and NH 3 Meters

1. Close the belly valve of the supply tank. 2. Close the valve on the vapor return line. 3. Close the manual valve in the supply line on the inlet side of the meter. If no manual valve exists on the inlet side, consult the truck manufacturer for procedures to depressurize the system.
4. Slowly open the valve/nozzle at the end of the supply line.
5. After product has bled off, close the valve/nozzle at the
6. Slowly crack the fitting on top of the differential valve to relieve product pressure in the system. Product will drain from the meter system.
7. As product is bleeding from the differential valve, slowly reopen and close the valve/nozzle on the discharge line. Repeat this step until the product stops draining from the differential valve and discharge line valve/nozzle.
8. Leave the discharge line valve/nozzle open while working on the system.

## Mounting Bolt Pattern

The LectroCount LCR-II base casting contains eight bolt holes in an industry standard bolt pattern. The holes are 1/2" deep and take 1/4"-20 screws.

If the installation necessitates that you fabricate a bracket, refer to the drawing to the right.

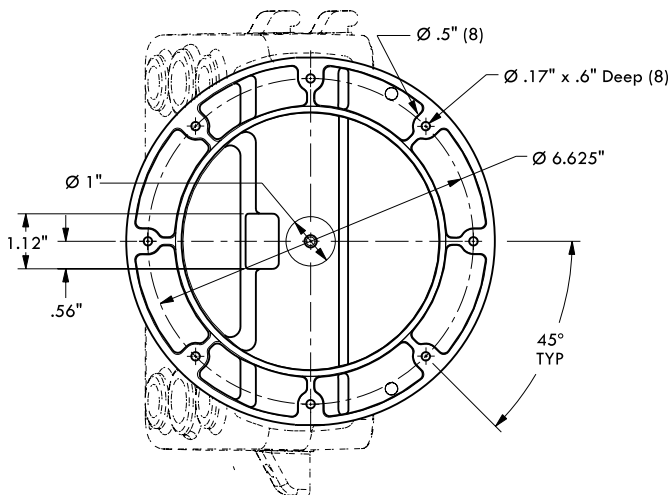

LCR-II Bolt Pattern

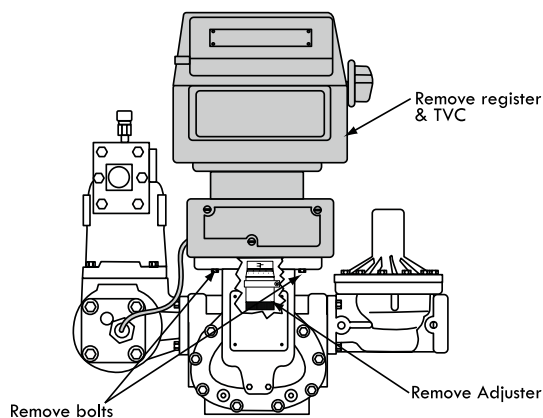

LC Meter Compensated

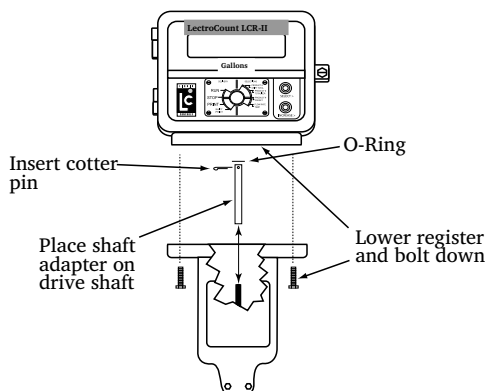

LC Meter

## LC Meters

### Remove Existing Registration Equipment

1. Depressurize the meter completely. See Warning on pg. 14.
2. Remove the four bolts on the bottom that fasten the register to the meter.
3. Remove the adjuster from the meter.
4. If the meter has a Temperature Volume Compensator (TVC), remove it as well.

### Mount the LectroCount LCR-II

1. Place the end of the shaft adapter on the pulser drive shaft located on the bottom of the register.
2. Place the cotter pin through the hole, and bend open the ends of the cotter pin.
3. Lower the register onto the meter, and insert the shaft adapter onto the hex shaft on the meter.
4. Securely bolt down the register.

### Apply Anti-seize

Apply anti-seize to all bolt threads to ensure easy removal at a later date.

# LCR-II Mounting

## Neptune Meters

### Remove Existing Registration Equipment

1. Depressurize the meter completely. See Warning on pg. 10.
2. Remove the mechanical register from the meter.
3. Leave the star-shaped gear and the two square-head studs.
4. Remove the bellows from the front of the meter.
5. Remove the compensator.

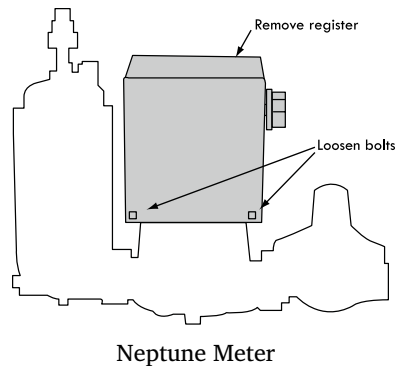

### Mount the LectroCount LCR-II

1. Install the drive fork and extension piece (pictured below) on the pulser drive shaft located on the bottom of the LCR-II.
2. Install the bracket on the meter, and fasten with the bolts provided in the kit.

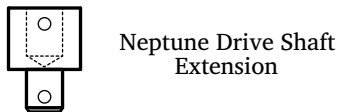

3. Lower the LCR-II on to the bracket, and securely fasten using the four bolts (1/4" x 3/4") provided.

### Apply Anti-seize

Apply anti-seize to all bolt threads to ensure easy removal at a later date.

### Mount the LectroCount LCR-II onto previously temperature compensated Neptune meters

1. Place the shaft adapter on the pulser drive shaft under the LCR-II.
2. Place the cotter pin through the hole, and bend open the ends of the cotter pin.
3. Pass the other end of the shaft adapter through the flange assembly and the weather plate.
4. Loosely bolt to register.
5. Place the drive fork and extension piece on the shaft using two more cotter pins.
6. Bolt the flange to the meter and tighten all bolts.

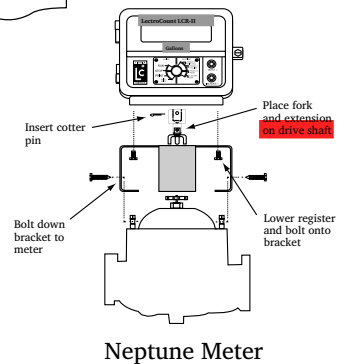
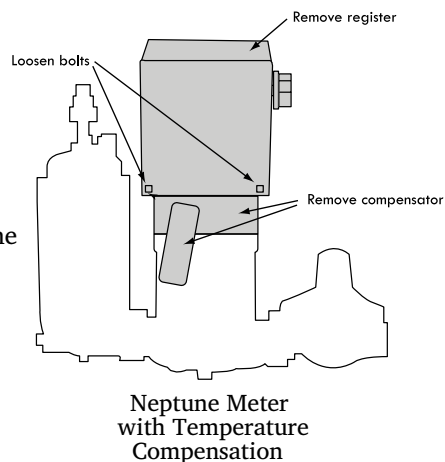

### Star Gear and Drive Fork

When the register is lowered onto a Neptune meter, make sure the drive fork is not pressed against the star gear on the meter. There must be a small gap between these two parts. To lower the star gear, loosen the set screw on the side of the star gear. Failure to do so will eventually damage the internal pulser and/or the meter gear train.

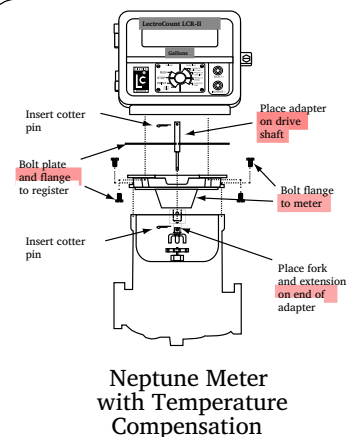

Installation kits 82641 (E-26 series) & 82642 (E-36 series) are specifically designed for previously temperature compensated Neptune meters.

# Routing LCR-II Data and Power Cables



## Data and Power Cable

The LCR-II shipment typically includes a gray 40' power cable and a 40' black data cable prewired to terminal blocks on the LCR-II CPU board. On typical truck installations, the cables must be routed from the back of the truck, where the LCR-II is installed, to the front of the truck, where the accessory panel is and the printer is typically installed. The black data cable connects to the printer, typically mounted in the truck cab. The gray power cable hooks up to a power source. During installation, follow these guidelines and ensure the cables remain undamaged.

### Guidelines for routing the data and power cables on the outside of the truck

- LC recommends that both cables be run through  $\frac{3}{4}$ " automotive plastic corrugated split loom or through flexible liquid-tight conduit for protection.
- Make sure the loom or conduit runs down the inside edge of the trucks frame rail and fasten every 2' with cable ties.
- Install rubber grommets to protect the cables where they pass through the cab wall, meter box, etc.
- Keep the cables away from heat sources such as the engine exhaust, manifold, exhaust pipe, mufflers, etc.
- If the cable glands are removed from the register, apply pipe sealant or PTFE tape on the gland threads before re-installing.
- Keep cables away from moving suspension components and other moving truck components.
- If the cables are shortened, make sure you use the proper tool for stripping off the insulation on the cables.
- Make sure cables are connected to the proper terminal.

### Guidelines for routing the data and power cables inside the cab

- Layout positions for the component and pathways for the cables before beginning.
- Make sure the printer and the wires will not obstruct other vehicle components.
- Keep cable pathways away from heavy traffic areas and locations where they may be vulnerable to damage.
- Remember to save room around the components so cables can be easily connected.
- Avoid installing the cable where it will be exposed to excessive flexing.
- Make sure cables are not pulled too tight in areas that will move. For example, when wiring cab-over trucks, leave enough slack so the cab can be tilted without damaging the cable.
- Make sure cables are not fastened to adjustable seats.

## Routing LCR-II Data and Power Cables

*Instructions for hooking up power to the printer and the LCR-II begin on pg. 29.*

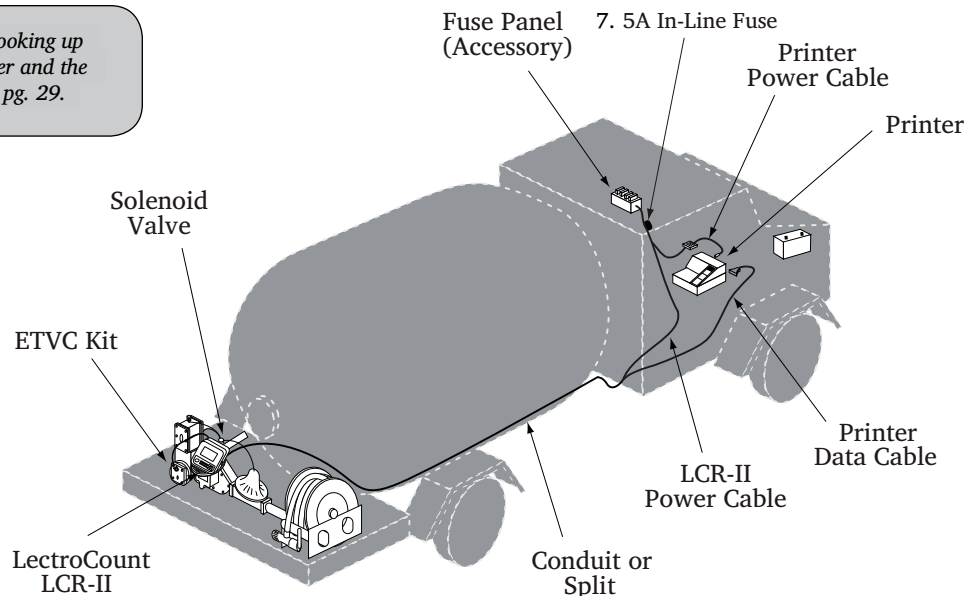

# Electronic Temperature Volume Compensation

## Electronic Temperature Volume Compensation (ETVC) Installation

When ordered as part of a meter system with a LCR-II, the ETVC kit is bolted onto the strainer and wired to the LCR-II at the factory. ETVC kits can also be ordered and retrofit onto meter systems already in service. Although there are several installation kits—kits are specified according to meter size and application—they are all installed in the same manner. A conduit kit (PN 81024), with a 30" length of weatherproof flexible conduit, is available from Liquid Controls to provide protection for the RTD temperature probe wire between the strainer cover and the LCR-II.

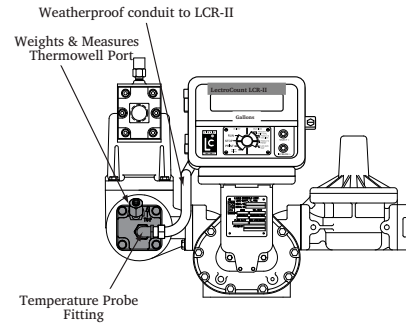

To install the ETVC kit:

1. Depressurize the meter completely. See Warning on pg. 14.
2. Remove the old strainer cover.
3. Clean the strainer basket and put it back in the housing.
4. Lightly coat the new cover gasket (included with the ETVC kit) with lubricant (do not use the included copper grease).
5. Fit the new cover gasket into strainer cover groove.
6. Bolt the strainer cover in place. *Make sure the Weights & Measures thermowell port is at the top of the cover.*
7. Assemble the thermowell kit (see Thermowell Kit figure on the left).
8. Coat the entire probe length with the copper grease provided. Insert and re-coat the probe 2 or 3 times to provide a uniform coating inside the thermowell and to ensure proper heat transfer from the liquid to the probe.
9. Connect the assembled thermowell to the fitting in the middle of the strainer cover. *The angled fitting at the top of the cover is for Weights & Measures purposes. See Step 6.*
10. Connect the conduit to a 1/2" NPT port on the back of the LCR-II using the elbow fittings provided with the conduit kit (PN 81024).
11. Wire the temperature probe to the LCR-II internal board on connector J14.

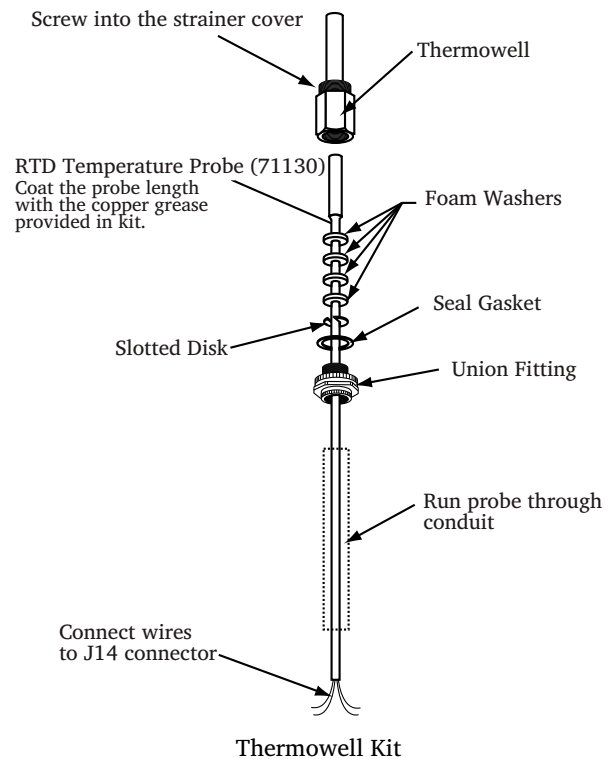

**Disconnect Power**  
Disconnect the power before working on the CPU board.

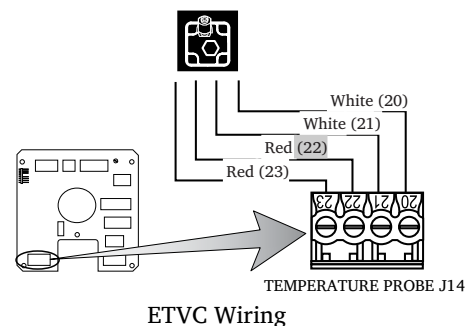

Single Stage Systems



A2847-11 Solenoid-Operated Block Valve

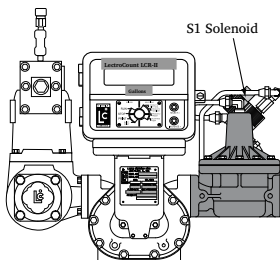

Single Stage (S1) Block Valve



A2859-11 Block Valve and 3-Way Solenoid

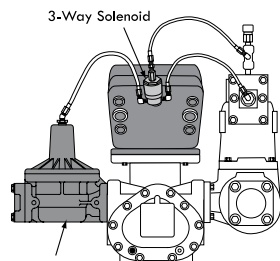

A2843 Block Valve  
Single Stage 3-Way Valve

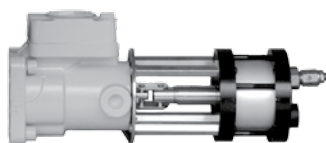

Electro-Pneumatic Preset Valve

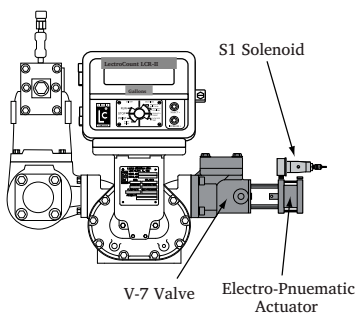

Single Stage Electro-Pneumatic Valve with V-7 Valve

Liquid Controls' Valves Overview

When ordered as part of a meter system with a LCR-II, Liquid Control's control valves are bolted onto the meter and wired to the LCR-II at the factory. Electronic control valves can also be ordered separately and retrofit onto meter systems already in service. These valves will need to be piped and wired in the field. For piping instructions, refer to the valve manual. This manual includes wiring instructions for the valves.

In order to control flow, the LCR-II energizes and de-energizes solenoid-operated valves on external bypass piping routed off the main product flow. The solenoid operated valves close off and open the bypass pipes. The bypass pipes redirect some of the product flow in order to open and close the control valve. These solenoid-operated valves must be wired to the LCR-II CPU board during installation.

Liquid Controls offers single stage and two stage electronic valves. Single stage valves have one solenoid valve (S1) and two positions—an open position and a closed position. Two stage valves have two solenoid valves (S1 & S2) and three positions—open, closed, and dwell flow. Dwell flow is a low flow rate setting controlled by the S2 solenoid and initiated shortly before the register reaches a preset value.

*The LCR-II is also compatible with many other brands and types of valves.*

**Single Stage Valves** The three most common Liquid Controls meter systems with single stage valves include a block valve with a S1 solenoid-operated valve fitted onto external piping (A2847-11), a block valve (A2843) with a 3-way solenoid, and an electro-pneumatic valve with an S1 solenoid.

**A2847-11 Valve** This single stage control valve has a S1 solenoid-operated valve located at the meeting point of three external pipes: one pipe from the inlet side of the valve, one from the top of the block valve, and one from the outlet side of the valve. This valve is typically used in refined fuels applications.

**A2843 Valve and 3-Way Solenoid** The 3-way solenoid-operated valve—mounted directly to the top center port on the back of the LectroCount LCR-II—serves as a S1 solenoid-operated valve. The 3-way solenoid-operated valve is located at the meeting point of two pipes from the vapor eliminator (one for eliminated vapor and one leading to the spit tank) and one pipe to the top of the block valve. 3-way solenoid-operated valves are typically specified for products that hold vapor in the line such as LPG and NH<sub>3</sub>.

**E-7 Valves** A two stage valve with a S1 and a S2 solenoid-operated valve. The E-7 valve is fitted with one external pipe to divert product flow to the closing mechanism. To supply a dwell flow, the E-7 redirects the product around the closed valve using channels molded into its housing. This valve is typically used in refined fuels applications. Single Stage Valves (Cont.) The three most common Liquid Controls meter systems with two stage valves are: a block valve with a S1 and a S2 solenoid-operated valve fitted onto external piping (A2848-11), a block valve with a S2 solenoid-operated valve (A2859-11) and a 3-way solenoid on the LCR-II, and an E-7 valve with a S1 and a S2 solenoid-operated valve.

**A2848-11 Valve** This two stage control valve has a S1 and a S2 solenoid-operated valve. The S1 solenoid-operated valve is located at the meeting point of three bypass pipes: one pipe from the inlet side of the valve, one from the top of the block valve, and one from the outlet side of the valve. The S2 solenoid valve is located on a bypass pipe that connects the inlet and outlet sides of the control valve. It opens while the control valve is closed to supply the dwell flow. This valve is typically used in refined fuels applications.

**A2859-11 Valve and 3-Way Solenoid** A two stage valve with a S2 solenoid-operated valve and a 3-way solenoid valve attached to the back of the LectroCount LCR-II. The 3-way solenoid-operated valve is located at the meeting point of two pipes from the vapor eliminator (one for eliminated vapor and one leading to the spit tank) and one pipe to the top of the block valve. The S2 solenoid valve is located on a bypass pipe that connects the inlet and outlet sides of the control valve. It opens while the control valve is closed to supply the dwell flow. This configuration is typically specified for products that hold vapor in the line such as LPG and NH 3 .

## Two Stage Systems



A2848-11 Solenoid-Operated Block Valve

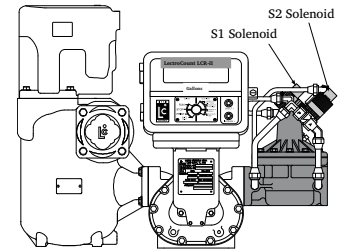

Two Stage (S1 and S2) Block Valve

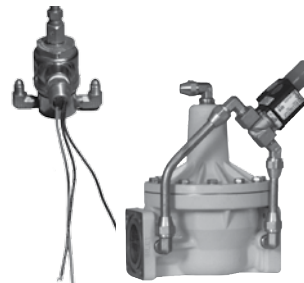

A2859-11 Solenoid-Operated Block Valve and 3-Way Solenoid

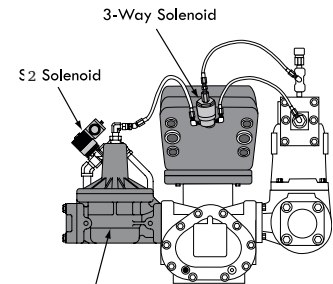

A2859-11 Block Valve Two Stage 3-Way Valve with (S2) Block Valve



E-7 Valve

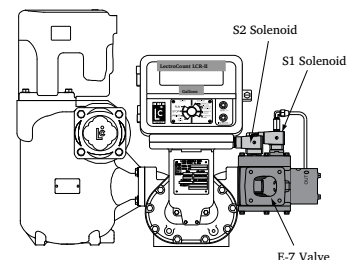

Two Stage (S1 and S2) E-7 Valve

## Disconnect Power

Disconnect the power before working on the CPU board.

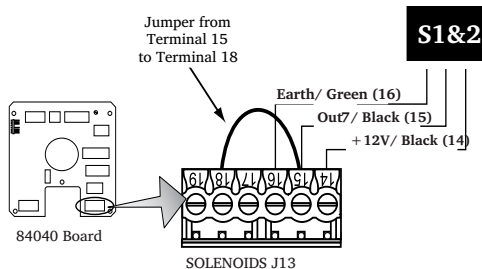

Solenoid 1 Wiring for Single Stage Valves

## Earth Grounds for Solenoid Valves

The Earth grounds for Terminals 16 & 19 are optional. The solenoid operated valves are grounded through the component they are mounted on.

## Valve Installation

If installing the valve yourself, please refer to the valve's installation and operation manual for mechanical installation. Instructions for wiring Liquid Controls valves to the LCR-II are on the following two pages.

Materials needed for wiring valves: Not supplied with the valve

- 20 AWG stranded wire (3 per solenoid). Not necessary for 3-Way solenoid valves. Only 2 needed for E7 solenoids.
- Weatherproof flexible conduit, 1/2" diameter and 1/2" NPT conduit connectors or cable glands
- PTFE tape or pipe sealant

To wire valves to the LCR-II:

1. Attach cable glands and/or conduit connectors to the solenoid valve(s) and the LCR-II port(s).
2. Thread the wires through piece of weatherproof conduit that is cut-to-length from the solenoid to a LCR-II port.
3. Run the weatherproof conduit between the solenoid-operated valve(s) and the LCR-II housing, pull the wires through the ports, and tighten the connectors.
4. Connect the S1 solenoid-operated valve wires to terminals 14 and 15 on the J13 terminal block of the LCR- II CPU board.
5. Connect the S2 solenoid-operated valve wires to terminals 17 and 18 on the J13 terminal block of the LCR- II CPU board.

To wire a single stage valves for presetting:

1. Wire the S1 solenoid as instructed above.
2. Run a jumper wire from Terminal 15 to Terminal 18.

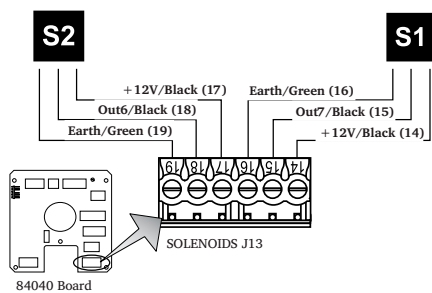
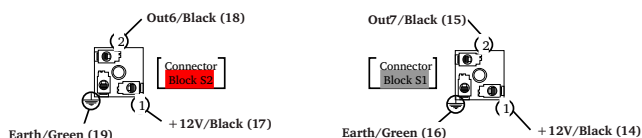

Solenoid 1 and Solenoid 2 Wiring for A2859-11 and 3-Way Two Stage, 2848-11 Two Stage, E7 Two Stage Wiring

## Solenoid Operated Valve Cables

Solenoid operated valve 81527 (3-way LPG solenoid) has 3 cables potted into the housing. All other solenoid operated valves on Liquid Controls valves use cable assembly 81859, which has 2 cables.

# Valves

Valves with 110VAC Solenoids In order for the LectroCount LCR-II to control valves with solenoids on 110 VAC circuits, you must install a relay switch on the positive leg of the solenoid's circuit.

Relay switch specifications:

**Switch: SPST (single pole, single throw)**

**Switch Position : Normally open**

**Contact Rating : Greater than maximum current of solenoid**

**Voltage : + 12 VDC**

Materials needed for wiring valves with 110 VAC solenoids: Not supplied with the valve

- SPST relay switch (1 per solenoid)
- 20 AWG stranded wire (2 per solenoid)
- Weatherproof flexible conduit, 1/2" diameter and 1/2" NPT conduit connectors or cable glands
- PTFE tape or pipe sealant

To wire 110 VAC solenoids to the LCR-II:

1. Turn off all 100 VAC circuits before beginning the installation.
2. Install the specified relay switch(es) onto one leg of the 110 solenoid power supply circuit.
3. Connect the relay switch on the S1 power supply circuit to terminals 15 and 16 on block J13.
4. Connect the relay switch on the S2 power supply circuit to terminals 17 and 18 on block J13.

## Disconnect Power (110VAC)

*Turn off all 110VAC circuits before beginning the installation.*

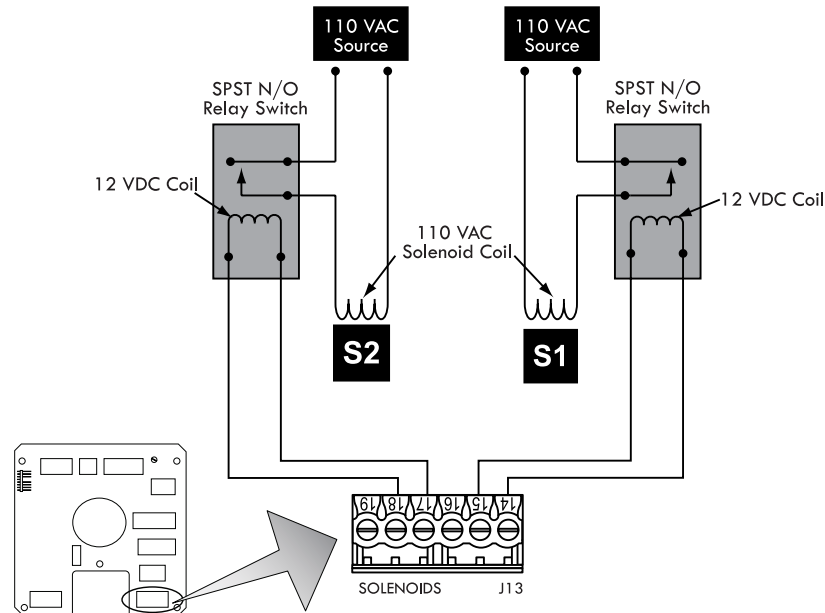

# Optical Air & Vapor Eliminators



Optical Air Eliminator:  
Refined Fuels



Optical Vapor Eliminator:  
LPG and NH<sub>3</sub>

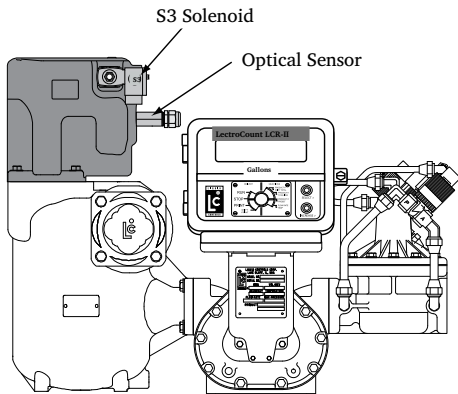

Meter System with Optical Air Eliminator

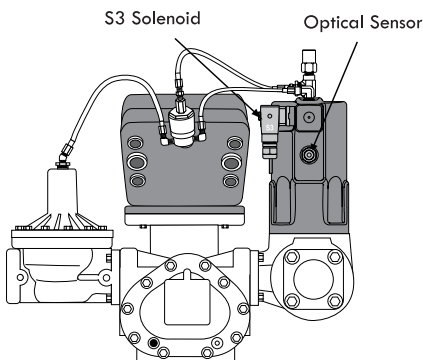

Meter System with Optical Vapor Eliminator

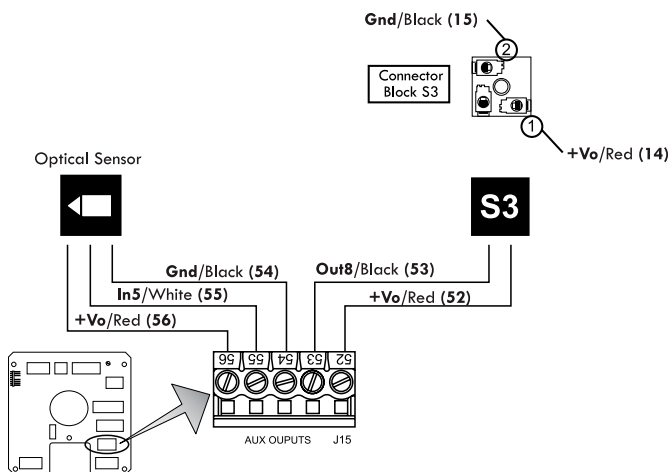

## Optical Air and Vapor Eliminator Installations

When ordered as part of a meter system with a LCR- II, Liquid Control's optical air and vapor eliminators are bolted onto the strainer and wired to the LCR-II at the factory. Optical air and vapor eliminators can also be ordered separately and installed onto meter systems already in service. For mechanical installation instructions, refer to the manual specific to the optical air and vapor eliminator. Instructions for wiring optical air and vapor eliminators to the LCR-II are provided on this page.

Materials needed for wiring valves: Not supplied with the air or vapor eliminator

- 20 AWG stranded wire (2 for the S3 solenoid valve)
- Weatherproof flexible conduit, ½" diameter and ½" NPT conduit connectors or cable glands
- PTFE tape or pipe sealant

To wire optical air and vapor eliminators to the LCR-II:

1. Attach cable glands and/or conduit connectors to the S3 solenoid valve, the optical sensor, and the LCR ports.
2. Thread the 20 AWG wires through a piece of weatherproof conduit cut-to-length from the S3 solenoid to a LCR-II port.
3. Run the weatherproof conduit between the S3 solenoid- operated valve and the LCR-II housing. Pull the wires through the ports, and tighten the connectors. *Liquid Controls recommends running the optical sensor wire through weatherproof conduit as well.*
4. Connect the three 20 AWG wires to the S3 solenoid-operated valve terminals and to terminals 52 and 53 on the J15 terminal block of the LCR-II CPU board.
5. Connect the optical sensor wires to terminals 54, 55, and 56 on the J15 terminal block of the LCR-II CPU board.

### Disconnect Power

*Disconnect the power before working on the CPU board.*

# Pulse Output Device (POD)

## Pulse Output Device (POD)

### Installation

When ordered as part of a meter system with a LCR- II, Liquid Control’s Pulse Output Device (POD) is installed onto the meter and wired to the LCR-II at the factory. The POD can also be ordered separately and installed onto meter systems already in service. For mechanical installation instructions, refer to the POD manual. Instructions for wiring the POD to the LCR-II are provided on this page.

Materials needed for wiring valves: Not supplied with the POD

- 22 AWG stranded wire (4)
- Weatherproof flexible conduit, ½" diameter and ½" NPT conduit connectors or cable glands
- PTFE tape or pipe sealant

To wire a POD to the LCR-II:

1. Attach cable glands and/or conduit connectors to the POD and the LCR-II port(s).
2. Thread the wires through a piece of weatherproof conduit cut-to-length from the POD port to a LCR-II port.
3. Run the weatherproof conduit between the POD and the LCR-II housing, pull the wires through the ports, and tighten the connectors.
4. Connect the four POD terminals to four terminals on the J18 terminal block of the LCR-II CPU board.
  - POD terminal 20 to LCR-II terminal 31
  - POD terminal 21 to LCR-II terminal 34
  - POD terminal 22 to LCR-II terminal 33
  - POD terminal 23 to LCR-II terminal 37

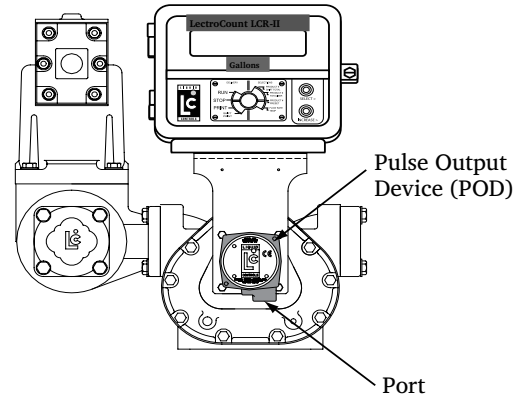

Meter System with Pulse Output Device

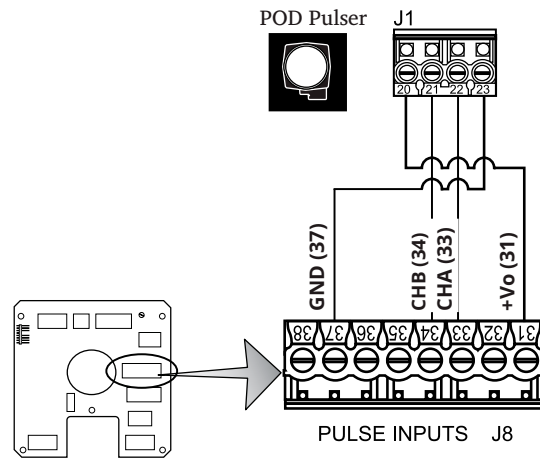

**Pulse Output Devices 1, 2, 3, & 4 Only**  
 This wiring schematic applies to pulse output devices 1 through 4 only.

**Disconnect Power**  
 Disconnect the power before working on the CPU board.

## Single Channel Pulse Inputs

The LCR-II is compatible with the many single channel pulsers and amplifiers, for example, the SP714 pulse amplifier. For the LCR-II to accept a single channel pulse, you will need version v1.15 (or above) of the SR260 base software and a jumper.

To a single channel pulse output to the LCR-II

1. Flash the CPU board with version v1.15 (or higher) SR260 base software.
2. Slide the jumper onto the bottom two pins of J17. The jumper fits over the pins and under the plastic casing.
3. Wire the single channel pulser to the J8 terminal of the board. *Schematic on the right shows wiring to a Sponsler SP714.*

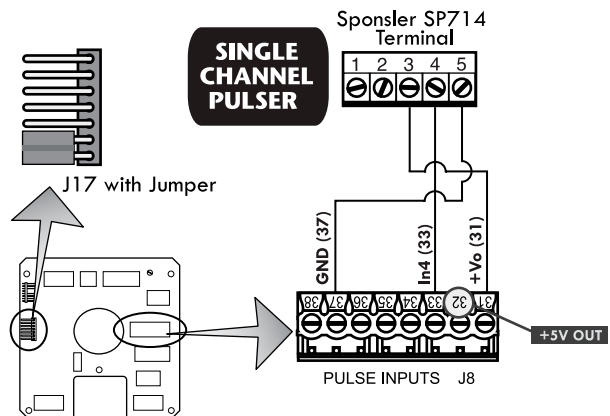

# Differential Pressure ( $\Delta P$ ) Transducer

## Differential Pressure ( $\Delta P$ ) Transducer Installation

When ordered as part of a meter system with a LCR-II, Liquid Control's  $\Delta P$  transducer is wired to the LCR-II at the factory. The  $\Delta P$  transducer can also be ordered separately and installed onto a meter system already in service. Refer to the  $\Delta P$  transducer manual for complete installation instructions. Instructions for wiring the  $\Delta P$  transducer to the LCR-II are provided on this page.

The  $\Delta P$  Transducer requires an additional board (PN 81944) that mounts directly to the LCR-II CPU board. Typically, a  $\Delta P$  transducer operates in conjunction with a shutdown device, such as a valve or a dead-man. The shutdown control must be wired to the LCR-II and should draw no more than 1 A.

To wire  $\Delta P$  Transducer to the LCR-II:

1. Unplug the J1, J2, and J3 terminal blocks from the LCR-II CPU board. Leave the wires in the terminals.
2. Remove the screw at the top left corner of the LCR-II CPU board.
3. Plug the 81944 board into the J1 connectors on the LCR-II CPU board.
4. Fasten the top left side of both boards to the housing with the screw provided.
5. Plug terminal block J1 into the 81944 board. Plug J2 and J3 back into the LCR-II CPU board
6. Plug terminal J16 into the 81944 board.
7. Route the  $\Delta P$  transducer cable through a cable gland in a port on the back of the LCR-II. Secure the cable gland. *LC recommends running the cable through weatherproof conduit.*
8. Connect the four  $\Delta P$  transducer wires to terminals J3 on the LCR-II CPU board and J16 on the 81944 board.
  - Black to J3 terminal 46
  - White to J3 terminal 51
  - Yellow to J16 terminal 57
  - Blue to J16 terminal 58
  - Red to J16 terminal 59
9. Run the red jumper wire (provided with the  $\Delta P$  transducer kit) from the J8 terminal 32 to J16 terminal 59 (+5 V).
10. Route a two wire cable from the shutdown control device through a cable gland in a port on the back of the LCR-II. Secure the cable gland. *LC recommends running the cable through weatherproof conduit.*
11. Connect the two wires from the shutdown control device to terminal block J13, terminals 14 and 15.

### Be Careful with the CPU Board

When removing the J1 or J16 terminal from the 81944 board, hold down the right end of the main CPU board to prevent flexing.

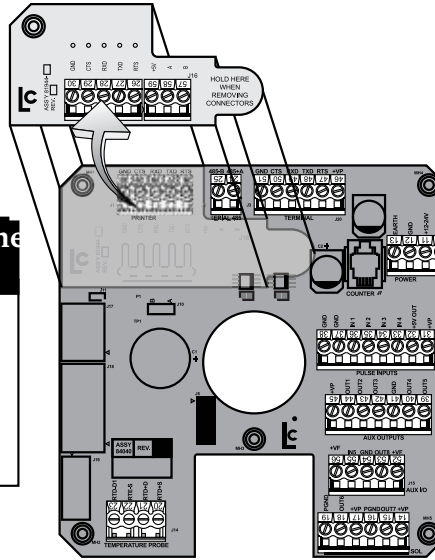

### $\Delta P$ Transducer

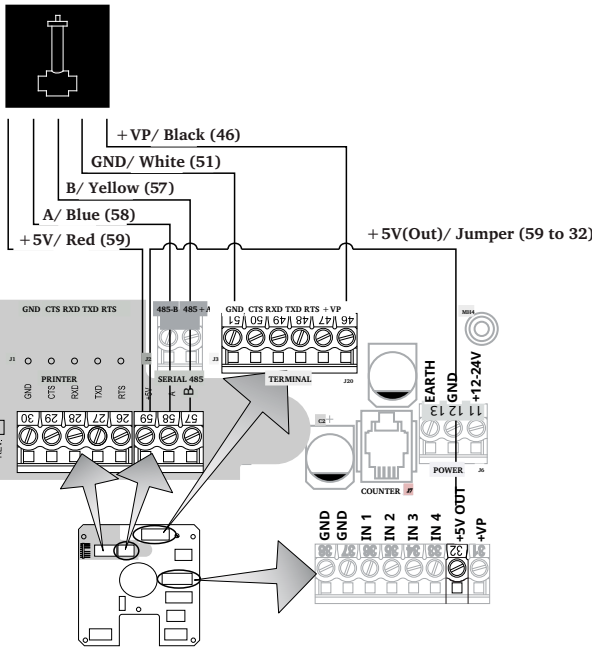

The shutdown device should draw no more than 1A.

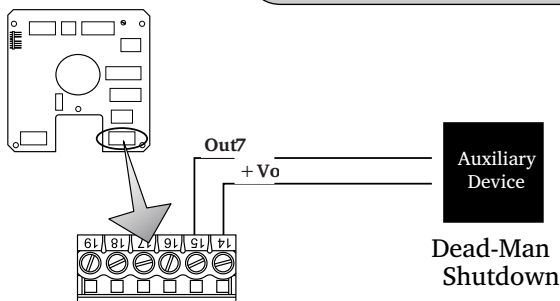

# Remote Display and Auxiliary Outputs

## Auxiliary Outputs 4 & 5 (LectroCount Remote Display)

Auxiliary outputs 4 & 5 are typically used for the LectroCount Remote Display, but they can also be used with other types of displays. Signals from these outputs duplicate the volume data sent to the LCR-II display. Refer to the LectroCount remote display manual for complete installation instructions.

To wire an external display to the LCR-II:

1. Attach cable glands and/or conduit connectors to the display and the LCR-II port(s).
2. Thread the wires through a piece of weatherproof conduit  
*Couper à la longueur nécessaire entre le port de l'afficheur et un port LCR-II.*
3. Installer le conduit étanche entre l'afficheur et le boîtier LCR-II, faire passer les câbles à travers les ports et serrer les connecteurs.
4. Connecter les quatre bornes de l'afficheur aux quatre bornes du bornier J18 de la carte CPU du LCR-II.
  - Borne 20 de l'afficheur distant vers borne 45 du LCR-II
  - Borne 21 de l'afficheur distant vers borne 39 du LCR-II
  - Borne 22 de l'afficheur distant vers borne 40 du LCR-II
  - Borne 23 de l'afficheur distant vers borne 41 du LCR-II

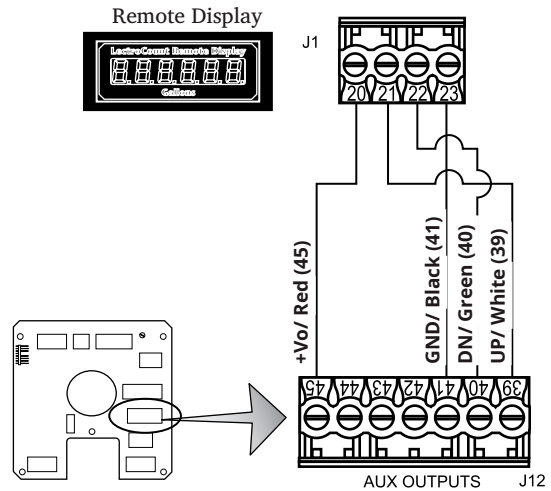

## Auxiliary Outputs

The LCR-II provides three open drain transistor auxiliary outputs for different external devices such as pump controls and additive injectors. The schematic to the right identifies the J13 terminals where the auxiliary outputs can be connected to the LCR-II.

### Auxiliary Output 1 (Out 1)

This signal has four output settings: Off, On, On During Delivery, and Monitor Flowrate.

### Auxiliary Output 2 (Out 2)

This signal has three output settings: Off, On, On During Delivery, and Flow Direction.

**Pulse Output (Out 3)** This output represents the gross delivery quantity for uncompensated deliveries or the net delivery quantity (for compensated deliveries). This output is a real time 50/50 duty cycle representing the least significant digit of the LCR-II totalizers.

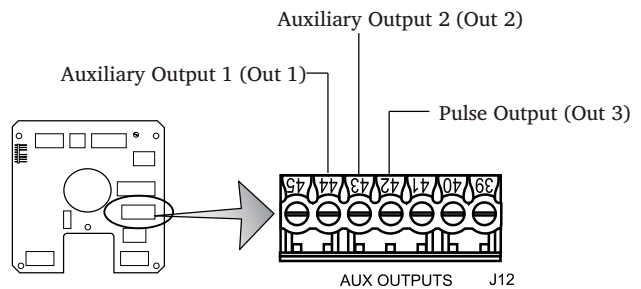

### Disconnect Power

*Disconnect the power before working on the CPU board.*

*To select the Auxiliary Output settings, refer to the LectroCount LCR-II Setup and Operation manual.*

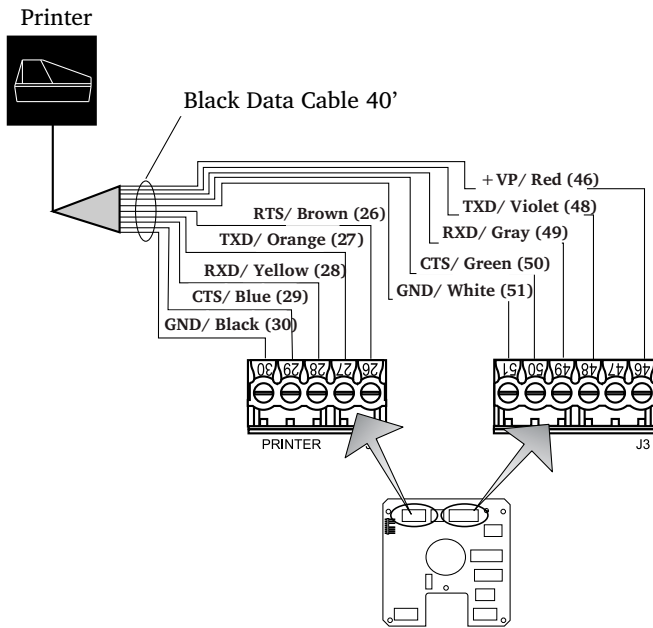

## Printer Installation

A Liquid Controls meter system with a LCR-II typically includes an Epson slip printer or roll printer. Installation is the same for both printers.

LCR-II's are typically shipped with a black-sheathed data cable prewired to terminals J1 and J3 on the LCR-II CPU board.

See instructions on pages 17 for routing the data cable from the back of the truck to the cab.

To install the printer:

1. Find a convenient mounting spot in the truck cab where drivers can easily operate the printer.
2. Clean the mounting spot and the bottom of the printer with alcohol for the best stick.
3. Attach the Velcro to the mounting spot and the bottom of the printer and fasten the printer to the mounting spot.
4. Connect the data cable to the RS-232 data port on the back of the printer.

For connecting power to the printer see pg. 29.

**RS-232 Communication**

To communicate via true RS-232 protocol, the +VP Red wire must be connected to the J3 terminal block at terminal 47 (not 46).

**Disconnect Power**

Disconnect the power before working on the CPU board.

- 82184 - Epson Printer Ground Wire Kit			
#	Description	Part Number	Qty
1	Ground Wire	84101	1
2	Terminal (.375 ring, 16GA)	71878	1

## Epson Printer Ground Wire Kit Installation

Before connecting power to the LCR-II and the Epson printer, ground the printer to the truck cab floor. Epson printers sold for truck installations are all grounded in the same manner.

To ground an Epson printer:

1. Remove one of the mounting bolts fastening the printer mounting brackets to the truck cab floor.
2. Place one end terminal of the ground wire over the mounting bolt and return the bolt to its original place.

**Additional Terminal**

The Epson Printer Ground Wire Kit contains an additional 3/8" ring terminal for printer brackets not purchased from Liquid Controls

3. At the back of the Epson printer, remove the silver ground screw marked "FG".
4. Place the other end terminal of the ground wire over the ground screw and return the screw to its original place.
5. Check the strap for a good ground connection (see page 13).

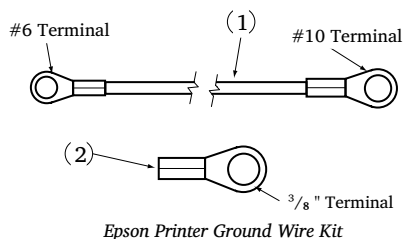

# Data Communications

## RS-232 and RS-485 Communications

The LCR-II is capable of interfacing with RS-232 and RS-485 communication protocols. Data connections for these protocols is made at the J2 and J3 terminal blocks. For standard RS-232 terminal, (other than the Lap Pad), the red +Vo input wire should be connected to J3-47.

A jumper, located on the left side of the CPU board, can also affect communication protocol. The jumper should stay in the B position for most applications; however, to use a lap pad (PN E40301 and E403011) the jumper must be moved to the A position. See the diagram and the table below.

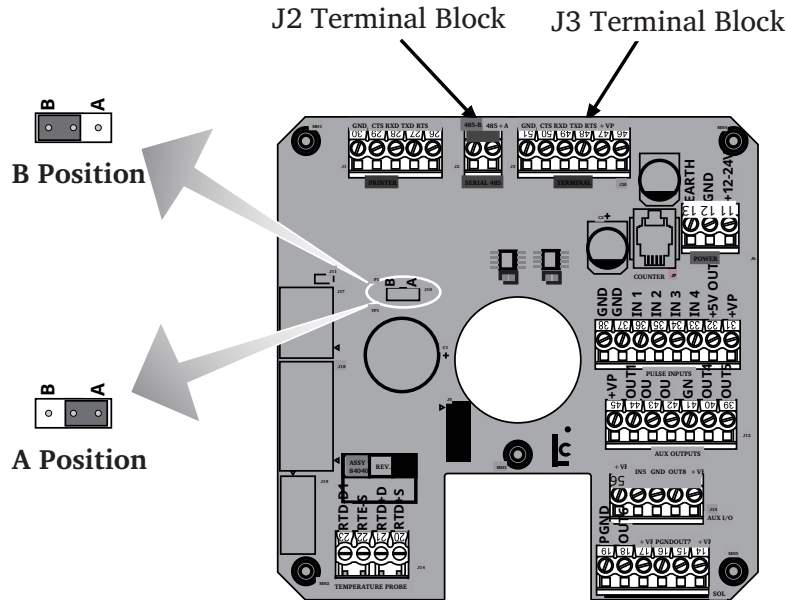

	Jumper Position	Data Connection	+Vo WIRE (Red)
<b>Lap Pad</b>	A	RS-232	J3 - 46
<b>CPU Board Flash</b>	A or B	RS-232	J3 - 47
<b>LCP Communication</b> <i>DMS, EZCommand, or compatible 3rd party application</i>	B	RS-232 or RS-485	J3 - 47
<b>Multimeter Network</b>	B	RS-485	J3 - 46
<b>RS232 Radio</b>	B	RS-232	J3 - 47

### Power Installation Overview

When you have made all of the data connections and finished installing all of the components, connect the power to the LCR-II and the Epson printer. But before making the power connections, go through the vehicle system checklist below, and ensure that the electrical system of the truck meets the minimum requirements for powering the LCR-II and the Epson printer.

### Vehicle System Checklist

- Clean any corrosion from the battery terminals and battery cable to guarantee a solid, tight connection.
- Charge the battery in accordance with the manufacturer's specifications.
- Ensure the alternator is large enough to meet the total demands of the truck, including the LCR-II. The LCR-II requires a minimum of 5 A for proper operation. Run the truck at low idle with all accessories on (including hose reel), and check the voltage with a multi-meter. The voltage should not drop below 11 V.
- Inspect the electrical equipment on the vehicle, and ensure it is properly installed and operating correctly.
- Determine whether the vehicle is grounded positively or negatively. Consult Liquid Controls if the vehicle has a positive ground.
- Make sure that any radio antennas are installed in accordance with the manufacturer's specification to prevent RF interference.

# Power Installation

---

## Connect the Power

All LCR-II shipments typically include a 40' gray power cable (100', and 300' are also available) and a 7.5A fuse.

*Page 17 describes describe the best practices for routing the gray power cable to the truck cab's accessory panel.*

**40' Gray Power Cable** The gray power cable (PN 84046) is prewired to the J6 terminal on the CPU board at the factory. It includes two 16AWG wires and a ground drain wire. The 7.5A fuse should be spliced into the red 16AWG wire as close to the power source as possible.

**Epson Printer Power** Power must be supplied to the Epson printer as well. A 15' cable with a 12/24VDC converter (825001) for printer power supply is also available. The red wire of this cable must be spliced into the red wire of the gray power cable on the LCR-II side of the 7.5A fuse.

To connect power to the LCR-II and the Epson printer:

1. Route the gray power cable to the accessory panel. See *page 17*.
2. Splice the red wire from the printer power cable into the red wire of the gray power cable.
3. Splice the 7.5A fuse into the red wire. Make the splice close to the direct power terminal connection in the accessory panel and on the power side of the splice made with the printer power cable.
4. Connect the red wire to the direct power supply terminal in the accessory panel.
5. Connect the black wire of the gray power cable to a reliable DC ground.
6. Connect the black wire of the printer power to a reliable DC ground.
7. Tape the green drain wire of the gray power cable back against the power cable.

## Power Check

After the LCR-II has been installed, check to make sure that it powers up correctly. The LCR-II display and the printer power light should come on when the truck's ignition is turned to the ON or to the ACC position. Make sure the printer power switch is on. If the LCR-II or the printer does not power up, check the wiring and the connections on the LCR-II CPU board against the manual.

Epson Printer Power Connections

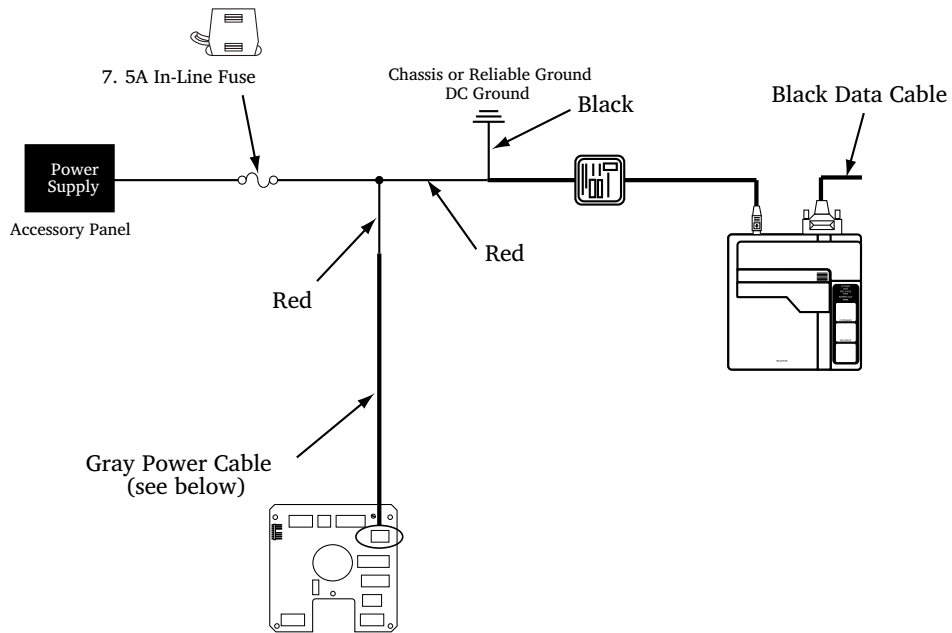

LectroCount LCR-II Power Connections

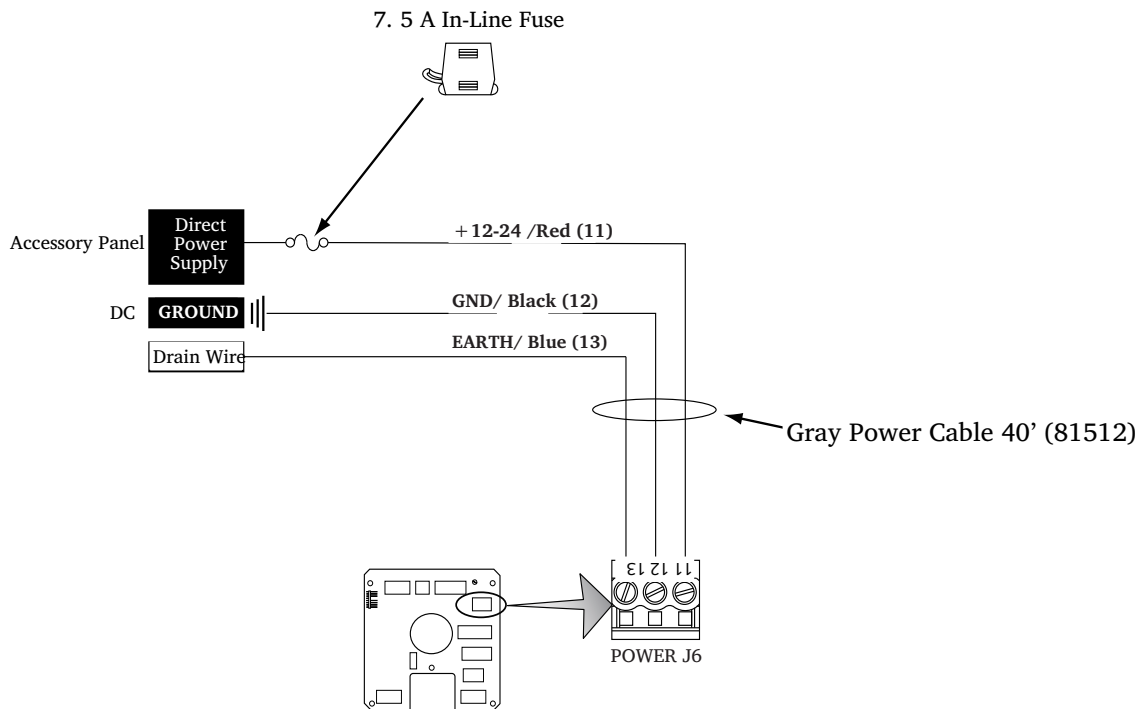

### IMPORTANT: Before Sealing the LCR-II

*After the LCR-II is powered correctly, continue on to the LectroCount LCR-II Setup and Operation manual to setup the LCR-II for operation. You will want to setup and test the LCR-II before closing and sealing the unit.*

### Close and Seal the Unit

Once the unit has been setup and tested, finish the installation by closing and sealing the housing. The LCR-II must be environmentally sealed to protect the electronics against the elements. The LCR-II must also be sealed by a Weights & Measures representative to guarantee the register is operating at the proper regulatory standards.

1. Secure the cables behind the LCR-II and the cables in the cab with cable ties.
2. If conduit was used during the installation, fill the conduit end inside the LCR-II with silicon RTV (provided with shipment, PN 82575). **Read and follow the directions of the Environmental Sealing Guidelines below .**
3. Tighten the cover bolt using a large flat-tip screwdriver or a 7/16" socket. Completely close the gap between the cover and the housing tab. **Read and follow the directions of the Environmental Sealing Guidelines below .**
4. Seal the cover bolt and the switch plate bolts with a wire/lead seal. **See Weights & Measures Seals on pg. 33.**

### Environmental Sealing Guidelines

The LCR-II includes sensitive electronic components, including a micro-controller that can be damaged by the presence of moisture. Therefore, it is essential that all conduit ports, the cover, and the shaft seals be adequately sealed by the installer to ensure watertight integrity. The conformal coating on the board and a moisture-absorbing desiccant inside the enclosure mitigates the problem of corrosion due to moisture, but these measures only protect the board from small amounts of moisture trapped inside the enclosure when the lid is closed in humid conditions. They are not capable of protecting the unit over time if a continuous leak is present in the enclosure.

### Sealing the LCR-II is the Responsibility of the Installer

*Any water or moisture damage to the LCR-II as result of improper sealing will not be covered under the product warranty.*

#### 1. Conduit Entrances

The LCR-II housing has seven conduit entrances, five ½" NPT female threads and two ¾" NPT. Use only ½" or ¾" NPT male threaded fittings on the conduit entrances. Pressed in Caplugs and straight (rather than tapered) threads are inadequate as seals for these entrances. Acceptable fittings are either metal or plastic conduit, pipe plugs, or cable glands. Threads should be treated with PTFE-based "pipe dope" or a minimum of two revolutions of PTFE tape prior to installation. Threads should be engaged a minimum of four full turns. When using cable glands, be sure the gland is sized properly for the outside diameter of the cable and the elastometric seal around the cable sheath is compressed onto the cable. Use only one cable per cable gland unless the gland is designed for multiple cables. When using conduit or Liquid-Tite, make sure that the opposite end is connected to an environmentally sealed device. If the conduit is not sealed at the other device, fill the interior of the conduit at the LCR-II with a silicone rubber sealant, such as RTV, to prevent moisture from running down the conduit into the enclosure.

#### 2. Cover Seals

To seal the LCR-II cover properly, ensure that the O-ring surrounding the cover is fit snug inside the groove, and tighten the cover screw securely.

#### 3. Shaft Seals

Units with internal pulsers have an O-ring around the pulse encoder drive shaft that extends through the bottom of the LCR housing. If a drive shaft adapter was attached at installation, make sure the O-ring around the shaft is securely seated in the counter bore of the casting, covered with the flat washer provided, and held in place with the cotter pin provided. The control switch on the front of the LCR-II is also sealed with an O-ring and held in place by a bushing secured with three socket head cap screws. When replacing a control switch in the field, make sure the O-ring is in place on the switch shaft before reinstalling the switch bushing.

## Post Installation—Bill Of Materials

### Weights & Measures Seals

To detect possible intrusions into Weights & Measures approved calibrations on a LectroCount LCR-II, fillister holes have been drilled into the switchplate screw and the latch. To seal according to Weights & Measures standards, a wire is threaded through the fillister holes and closed with a lead seal.

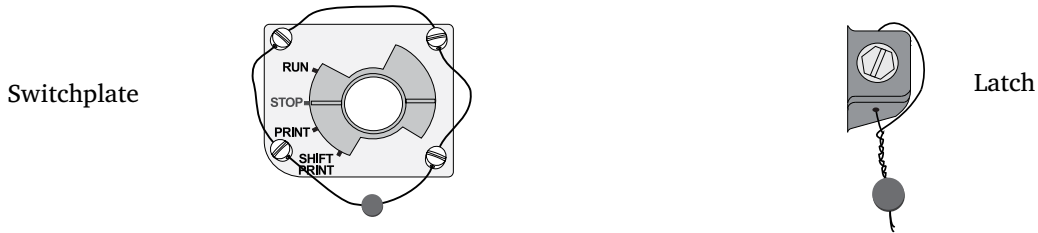

### Bill Of Materials—External Components

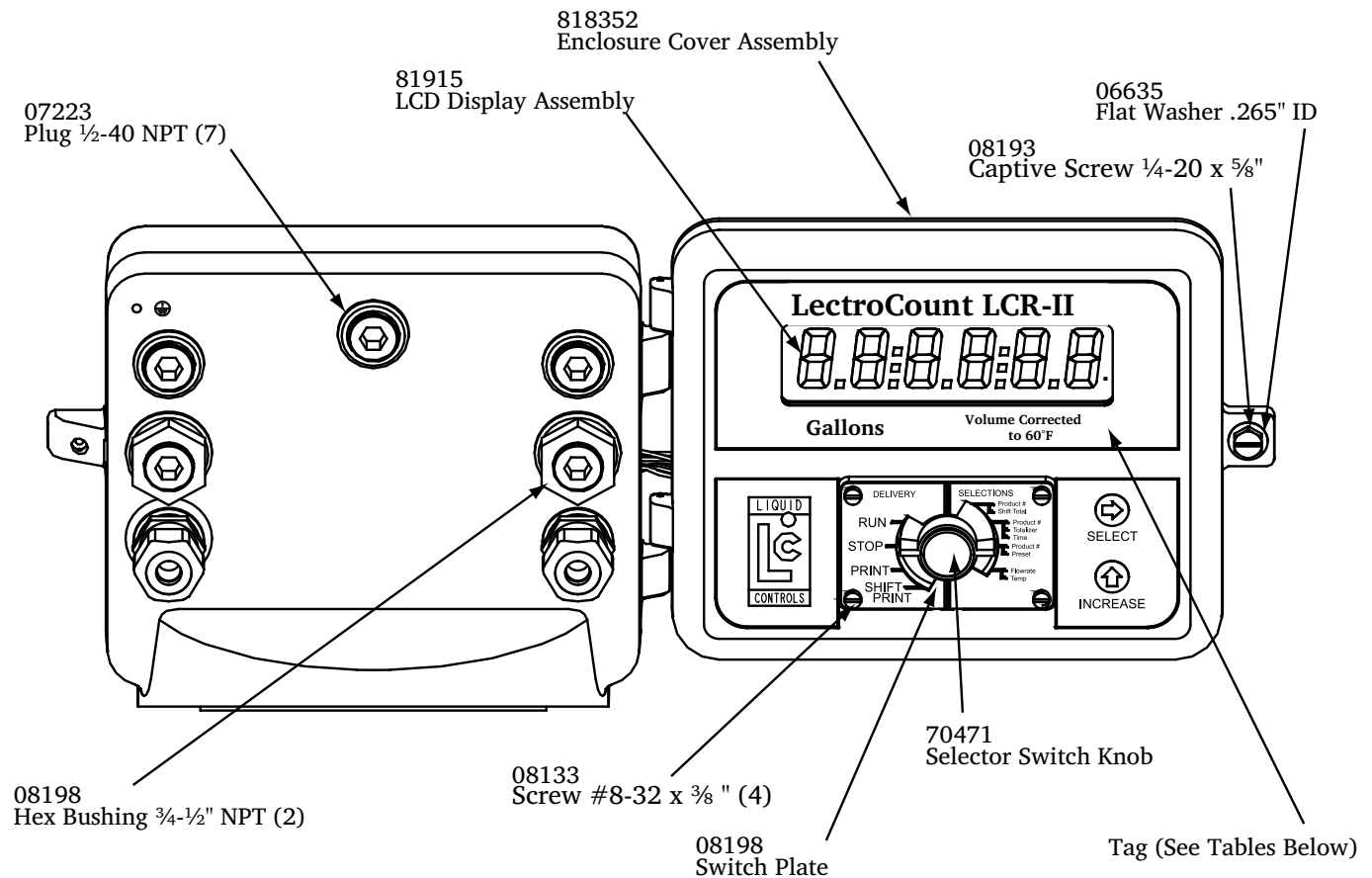

LectroCount LCR-II With Pulser			LectroCount LCR-II Without Pulser		
LCR-II PN	Description	Tag PN	LCR-II PN	Description	Tag PN
E365607	LCR-II W/ Pulser and No Tag		E365507	LCR-II W/O Pulser and No Tag	
E365617	LCR-II W/ Pulser and Gross Gallons Tag	818271	E365517	LCR-II W/O Pulser and Gross Gallons Tag	818271
E365627	LCR-II W/ Pulser and Net Gallons Tag	818272	E365527	LCR-II W/O Pulser and Net Gallons Tag	818272
E365637	LCR-II W/ Pulser and Gross Litres Tag	818273	E365537	LCR-II W/O Pulser and Gross Litres Tag	818273
E365647	LCR-II W/ Pulser and Net Litres Tag	818274	E365547	LCR-II W/O Pulser and Net Litres Tag	818274
E365657	LCR-II W/ Pulser and Pounds Tag	818275	E365557	LCR-II W/O Pulser and Pounds Tag	818275
E365667	LCR-II W/ Pulser and Kilograms Tag	818276	E365567	LCR-II W/O Pulser and Kilograms Tag	818276

# Bill of Materials - Internal cOMPONENTS

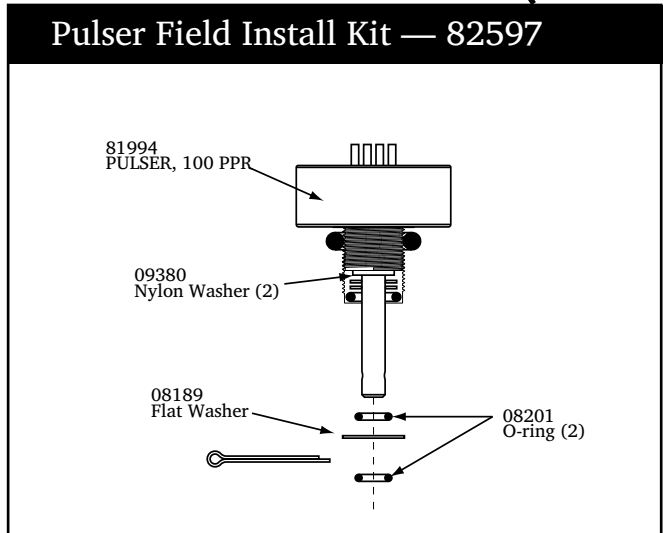
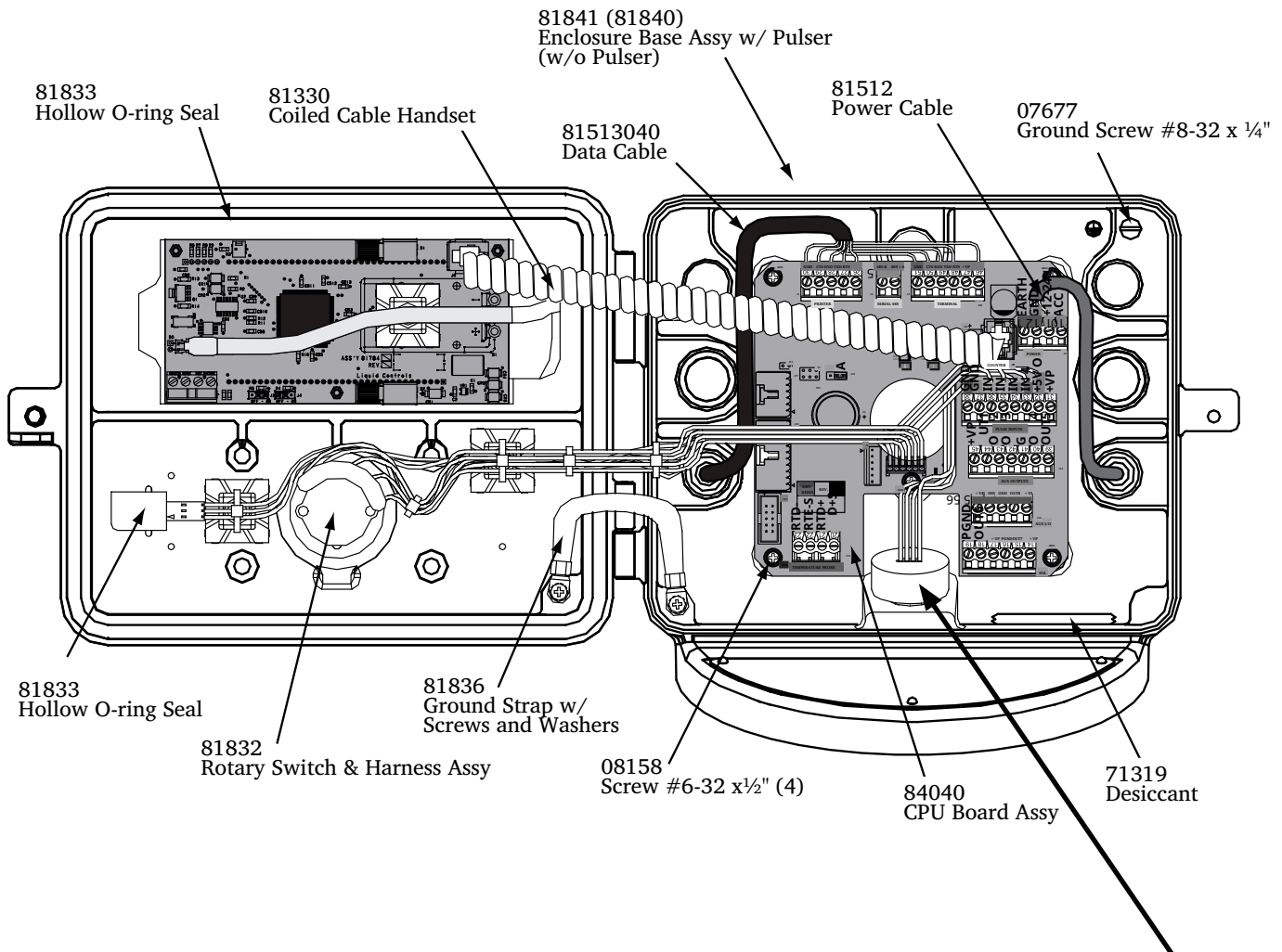

Optional Items (not shown)	
Description	Part Number
Printer Extension Cable	71237
Flash Cable	81885
Lap Pad Adapter	81514
Lap Pad	E40301
Lap Pad with Adapter	E403012

# Bill of Materials - CPU Boards

## 84040-4 (and 84040) CPU Board

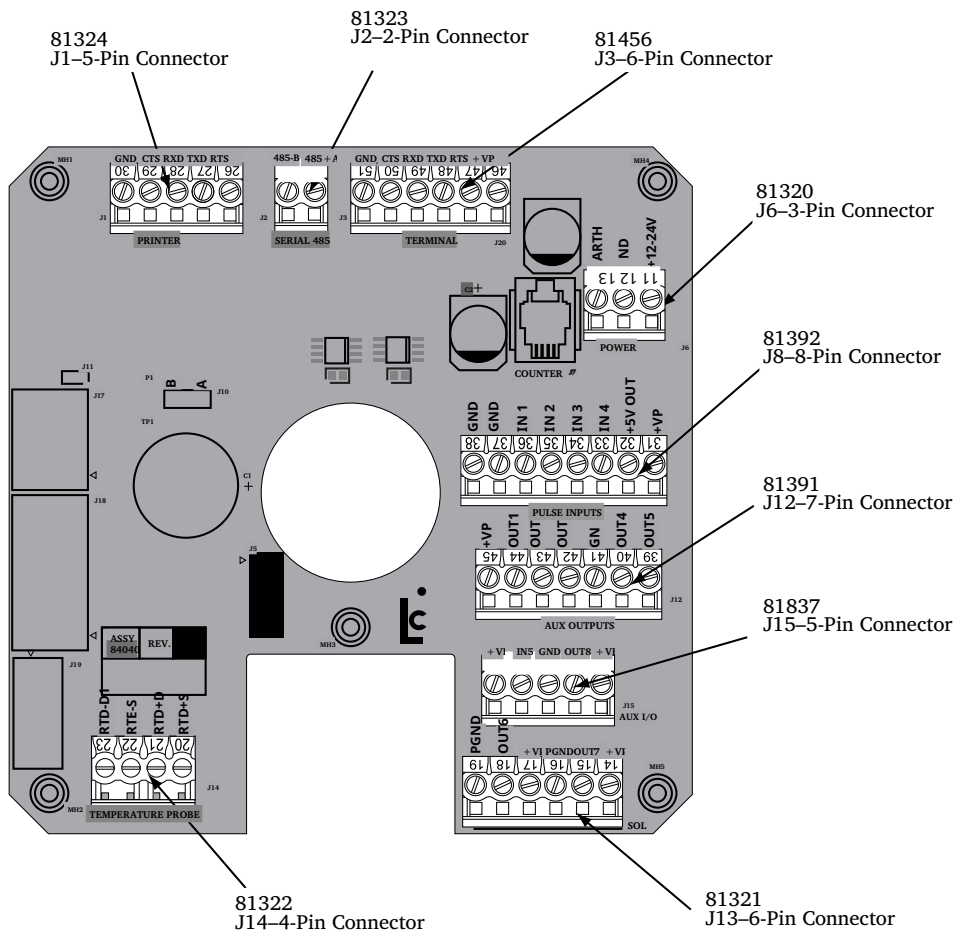

## 81547-2 CPU Board

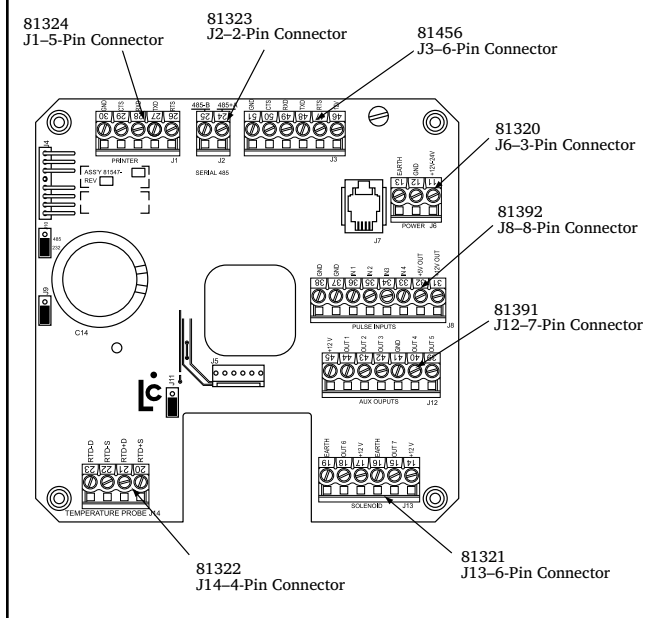

## 81920 CPU Board

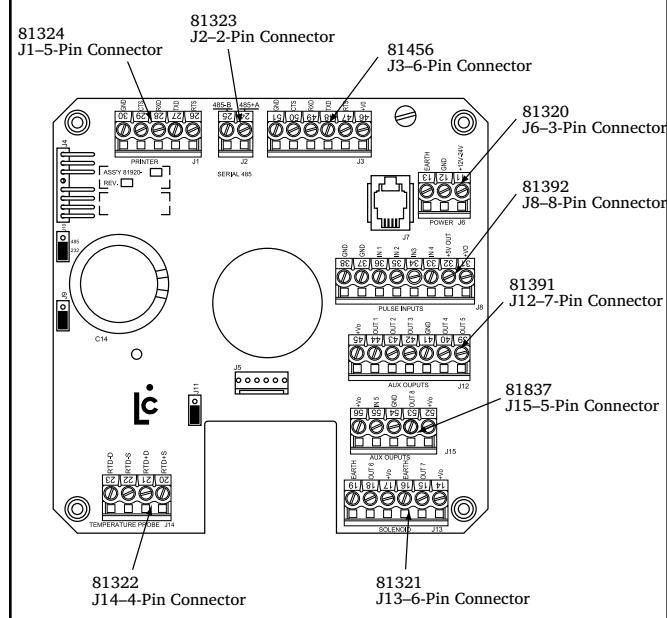

81547-2 is obsolete. CPU board shown here for maintenance reference

# **LIQUID CONTROLS GROUP**

**CORKEN · FAURE HERMAN · LIQUID CONTROLS · SAMPI · SPONSLER · TOPTech SYSTEMS**

**Liquid Controls**  
105 Albrecht Drive  
Lake Bluff, IL 60044  
(847) 295-1050

**SAMPI**  
Via Amerigo Vespucci 1  
55011 Altopascio (Lucca), Italy  
+ 39 0583 24751

**IDEX Fluid and Metering Pvt.  
Ltd. Survey No. 256, Alindra  
Savli GIDC, Manjusr Dist.  
Vadodara 391 770 Gujarat,  
India + 91 265 2631855**

**Toptech Systems**  
1124 Florida Central Parkway  
Longwood, FL 32750  
(407) 332-1774

Nateus Business Park  
Nieuwe Weg 1-Haven 1053  
B-2070 Zwijndrecht (Antwerp), Belgium  
+ 32 (0)3 250 60 60

**Faure Herman**  
Route de Bonnetable  
B. P. 20154  
72406 La Ferté-Bernard Cedex, France  
+ 33 (0)2 43 60 28 60

4708 North Sam Houston Parkway West  
Suite 100  
Houston, TX 77086  
(713) 623-0808

**Corken**  
3805 Northwest 36th St.  
Oklahoma City, OK 73112  
(405) 946-5576

105 Albrecht Drive  
Lake Bluff, IL 60044-2242  
1. 800.458.5262 • 847.295.1050  
Fax: 847.295.1057  
www.lcmeter.com

© 2010 Liquid Controls  
Pub. No. 502060  
(7/13)

