



Guid



CENTRILOGiO®

b LIQUI CONTROLS®

Table des matières

Ressources dans ce guide	3
Aperçu du registre	4
Mises à jour de publication	
5 Procédures de sécurité	
6 Spécifications	8
Conformité et certifications	12
Vérification d'une bonne mise à la terre	
.....	16 Conformité FCC
.....	17 Dimensions -
Montage sur panneau	19
Dimensions - Montage compteur	
22 Installation	23
Schéma de câblage	26 Kit
de bracelet de terre	28
Fixer le bracelet de terre	29
Utilisation de capteurs de sécurité intrinsèque	
.....	32 Vérification d'une bonne mise à la terre
.....	33 Aperçu du montage
.....	35 Montage du registre
.....	37 Câblage des câbles de données
et d'alimentation	42 Installation de l'ETVC
.....	44 Configuration des entrées
et sorties	47 Carte d'extension
SENSEiQ™	55 Commandes à distance -
Démarrage, Arrêt & Impression	58 Vannes
.....	59 Éliminateurs
optiques d'air et de vapeur	60 Dispositif à
sortie impulsionnelle	75
Transducteur de pression différentielle	82 Kit
antenne externe	83 Détecteurs
d'eau	92 Imprimantes
.....	94 Impression en
mode pass-through	97 Affichage
distant à grands chiffres	102
Alimentation électrique	
105 Finalisation de l'installation	
107 Identification de la carte d'interface	
111 Vérification des courts-circuits tension et masse	34

LCR.iQ Register

Congratulations on ownership of the new LCR.iQ electronic meter register and controller. This manual provides the technical details on installation, hardware, setup, operation, and regulatory information for your register.

NOTE: Throughout this manual, LCR.iQ is referred to as “Register” (unless otherwise specifically referenced by name).

The Register calculates, monitors and records volumetric data from bulk flow meters, provides fluid transfer process customization and automation, ties in critical system sensors and inputs, and bridges data communication between the operator, the equipment, and the operator’s back office if necessary.

The Register is specially designed to work with leading bulk fuel meters such as LC and Avery-Hardoll, but will easily retrofit into existing systems with other flow meter brands.

The Register provides many new features, yet supports backward compatibility with LCR-II and LCR-600.



Resources in this Guide

You can easily download PDF editions of the Installation Guide, Setup and Operations Guide, and wiring diagrams by clicking the links below.

Sinon, vous préférerez peut-être commencer par l'Aperçu du registre du Guide d'installation et du Guide de configuration et d'utilisation.

 , ou passer directement à la consultation

Guides Adobe PDF

Téléchargez l'un ou l'autre des guides en utilisant les liens ci-dessous :

- Installation Guide
- SPANISH Installation Guide
- Setup and Operations Guide

Wiring Diagrams

Download a high-resolution PDF edition of these wiring diagrams:

- Rev E board - Download the full-size wiring diagram .
- Rev J board - Download the full-size wiring diagram .

Register Overview

The Register is a microprocessor-based electronic meter register that can be used for Weights & Measures approved custody transfer actions in mobile or fixed installations. The Register is a self-contained unit. All operation, setup, and configuration functions can be carried out using the Register function keys and alphanumeric keypad. No lap pads, laptops, or other data entry devices are required.

A complete Liquid Controls meter system not only accurately measures product, it also regulates product flow and removes contaminants in order to produce the optimal conditions for measurement. Typical systems include an vapor/vapor eliminator, strainer, meter, register, and control valve.

Fonctions de base

Les fonctions principales des registres du Registre incluent :

- Transfert de garde Poids et Mesures (livraison de produit et génération de ticket)
- Collecte de données métrologiques
- Livraisons prédéfinies par volume
- Sélection multiple de produits
- Étalonnage multipoint du compteur
- Paramètres de sécurité
- Élimination d'air et de vapeur (avec accessoires appropriés)
- Contrôle de vanne monoétagé et biétagé (avec accessoires appropriés)
- Compensation électronique de volume par température (ETVC)

Mises à jour des publications

Les versions les plus récentes de toutes les publications de Liquid Controls sont disponibles sur notre site web, www.LCmeter.com/resources/technical/manuals . If there are questions about the language or interpretation of any LC manuals, instructions, or specification sheets, please first contact your local distributor for help with your inquiry.

For service related issues that require further support from the Liquid Controls Service Team, please call the number below.

Liquid Controls Corporate Office:

Phone: +1 847 295-1050 Toll-free: 800 458 5262 Address: Liquid Controls LLC, 105 Albrecht Drive, Lake Bluff, IL 60044 USA Website: www.LCmeter.com

Safety Procedures



BE PREPARED

Before using this product, read and understand the instructions. · All work must be performed by qualified personnel trained in the proper application, installation, and maintenance of equipment and/or systems in accordance with all applicable codes and ordinances.

· When handling electronic components/boards, always use proper Electrostatic Discharge (ESD) equipment and follow proper procedures.

Make sure that all necessary safety precautions have been taken. · Provide for proper ventilation, temperature control, fire prevention, evacuation, and fire management.

Provide easy access to appropriate fire extinguishers for your product. · Consult with your local fire department, state, and local codes to ensure adequate preparation.

Read this manual and all the literature provided in your owner's packet. · Conservez ces instructions pour référence future. · Le non-respect des instructions de cette publication pourrait entraîner des blessures personnelles, ou la mort par incendie et/ou explosion, des dommages matériels, ou d'autres dangers associés à ce type d'équipement.



VIDANGER SÉCURITAIREMENT LE SYSTÈME DE TUYAUTERIE

Avant le démontage de tout compteur ou composant accessoire : **TOUTES LES PRESSIONS INTERNES DOIVENT ÊTRE RELÂCHÉES ET TOUS LES LIQUIDES DOIVENT ÊTRE VIDANGÉS DU SYSTÈME CONFORMÉMENT À TOUTES LES PROCÉDURES APPLICABLES.**

La pression doit être de 0 (zéro) psi. · Fermez toutes les conduites de liquide et de vapeur entre le compteur et la source de liquide.

Le non-respect de cet avertissement pourrait entraîner des dommages matériels, des blessures personnelles ou la mort par incendie et/ou explosion, ou d'autres dangers pouvant être associés à ce type d'équipement.



RESPECTEZ LES NORMES NATIONALES ET LOCALES

Le câblage d'alimentation, d'entrée et de sortie (E/S) doit être conforme à la classification de zone pour laquelle il est utilisé (Classe I, Div 2). Pour l'Amérique du Nord, les installations doivent être conformes au National Electrical Code des États-Unis, NFPA 70, ou au Code canadien de l'électricité afin de maintenir les classements Classe I, Division 2. Cela peut nécessiter l'utilisation de connexions ou d'autres adaptations conformes aux exigences de l'autorité compétente.

L'équipement périphérique doit être adapté à l'emplacement dangereux où il est installé.

AVERTISSEMENT : Risque d'explosion

Lorsque vous vous trouvez dans des zones dangereuses, COUPER l'alimentation avant de remplacer ou de câbler les modules.

NE PAS déconnecter l'équipement à moins que l'alimentation n'ait été COUPÉE ou que la zone ne soit reconnue comme non dangereuse.

AVERTISSEMENT : Utiliser un couple de serrage de 3,5 in·lb (0,4 N·m) screws.

Preventing ESD Damage

Pour prévenir les dommages causés par les décharges électrostatiques (ESD), les installations sur camion doivent correctement mettre à la terre le coussin du siège et le châssis de l'imprimante Epson. Une exposition prolongée aux ESD sur des semaines, des mois ou des années peut corrompre la mémoire des registres et endommager les composants électroniques des caisses enregistreuses (ainsi que d'autres composants électriques du système électrique du camion).

Les sièges réglables et amortisseurs, s'ils ne sont pas correctement mis à la terre, génèrent des quantités importantes d'ESD. Les pivots et charnières de ces sièges isolent le coussin de la mise à la terre électrique. Sans liaison adéquate, une charge électrostatique s'accumule entre le coussin du siège et le

operator. This electric charge can enter the Register from any point in the truck electrical system, including register power and printer cabling.

Specifications

Mechanical

Housing and Keypad

The Register housing and bases are aluminum castings that are powder-coated with high durability, urethane powder. The cover internal hinge design provides easy access to the internal connections and keeps all moving hinge parts out of the elements to further prevent corrosion. Weights and Measures features are accessible by using a seal-able fastener on the side of the cover.

Construction Materials

- High grade A360 Die Cast Aluminum, enclosure cover, and enclosure base
- Finition chromate avec revêtement protecteur en poudre
- Vitrine en verre trempé
- Joint en silicone pour vitrine
- Support d'affichage en acier inoxydable
- Joint de porte en silicone
- Clavier - Commutateur à membrane avec revêtement en silicone
- Fixations/pièces de quincaillerie en acier inoxydable
- Rondelle d'étanchéité en silicone liée à l'acier inoxydable

Indice de température de fonctionnement certifié

- L'appareil est certifié pour un fonctionnement normal dans la plage de température de -40 à 140 °F (-40 à 60 °C) (-40 to 60 °C).

Display

- 7 inch heavy duty, high definition TFT/LCD (Thin Film Transistor Liquid Crystal Display) video display with LED backlight unit.

- 800 x 480 pixels (152.4 mm x 91.4 mm)
- Luminance: 1500 (cd/m²)
- Plage de température acceptable pour le fonctionnement ou le stockage : -40 °F à 185 °F (-40 °C à 85 °C).

Poids

- Environ 14 lbs / 6,5 kg (sans accessoires supplémentaires)

Entrées de câbles

- Dix (10) ports filetés 1/2 pouce NPT (1/2-14 NPT)

Clavier alphanumérique

Le clavier alphanumérique du terminal est fabriqué en silicone résistant aux hydrocarbures et comprend 12 grandes touches alphanumériques, 5 touches de navigation et 5 touches de fonction qui correspondent aux indicateurs d'affichage adjacents pour une fonctionnalité guidée par l'opérateur. Les touches, lorsqu'elles sont enfoncées, donnent à l'opérateur une confirmation tactile positive des frappes. La fonctionnalité multi-appui du clavier permet également aux utilisateurs de saisir jusqu'à quatre caractères alphanumériques sur une seule touche.

Electrical

Entrées

Les entrées sont configurables dans le registre pour gérer une variété d'accessoires externes qui fournissent des signaux de données dans le système de comptage, y compris l'entrée d'impulsions et divers capteurs externes.

Tension d'entrée du registre

- Tension – 9 à 28 VCC
- Courant maximum : 5 A max

Entrée d'impulsions

Afin de calculer les mesures de débit lorsqu'il est monté sur un compteur volumétrique, le registre reçoit une entrée d'impulsions d'un générateur d'impulsions en quadrature qui est mécaniquement connecté au

arbre de sortie du débitmètre (option montage sur compteur uniquement). Une entrée d'impulsions peut également provenir d'un dispositif externe tel qu'un Dispositif à Sortie d'Impulsions (POD) Liquid Controls ou d'un autre générateur d'impulsions monté en externe. Si un POD LC externe est acheté, ces matériaux sont nécessaires, mais ne sont pas fournis avec le POD :

- Câble blindé 4 conducteurs 16-22 AWG (Consultez le manuel du POD pour les spécifications complètes)
- Conduit flexible étanche aux intempéries ou gaine
- Raccords de conduit ½” ou presse-étoupes

Sonde de température RTD

Le registre est équipé d'une entrée pour une sonde de température, lui permettant de lire la température en temps réel et de compenser les mesures de volume en fonction de la température du produit.

- Capteur platine 4 fils
- 100 Ω de résistance à 0 °C
- Résistance de 138,5 Ω à 100 °C

Éliminateur d'air optique

Le registre est équipé pour traiter une entrée d'éliminateur d'air optique :

- Tension : 10 à 28 VCC
- Courant : 0,5 A maximum

Entrées numériques 1, 2, 3, 4, 5 et 6

- Actif à l'état bas, normalement maintenu à l'état haut
- Tension : 5 à 28 VCC
- Courant : 3 mA maximum (courant de puits)
- Fréquence maximale : 10 kHz

Outputs

The Register is equipped with six digital outputs and four solenoid outputs. These outputs allow the Register to communicate with meter system accessories such as solenoid- controlled valves, optical air and vapor eliminators, remote displays, printers, and third-party devices.

Digital Outputs 1, 2, 3, 4, 5, and 6

- Open drain output, active low to ground, thermally protected
- Voltage: 5 to 28 VDC
- Current: 500 mA maximum

Outputs for solenoids 1, 2, 3, and 4

- Open drain output, active low to ground, thermally protected
- Voltage: 12 VDC nominal
- Current: 1 A maximum
- Voltage: 24 VDC nominal
- Current: 0.5 A maximum

Pulse Output

- Voltage peak to peak – 5 to 28 V
- Frequency maximum – 7500 Hz

Scale Pulse Output

- Current sinking capability: 150 mA

Electrical Protection

- 5 A fuse on power cable

Communications

- RS-232
- RS-485
- CAN BUS – Consult the applicable Chassis Builder’s Guide, available from the truck chassis manufacturer.
- Ethernet (Gigabit)
- Bluetooth (wireless)
- Wi-Fi (wireless)

Printer (Epson Model 295)

- Voltage – 24 VDC
- Current – 0.8 Amp maximum
- Operating Temperature – -22 to 104 °F (-30 to 40 °C)

Regulatory & Certifications

The equipment is Listed by UL to applicable US and Canadian standards for use in hazardous locations under Liquid Controls file E180172.

LCR.iQ Serial Number tags

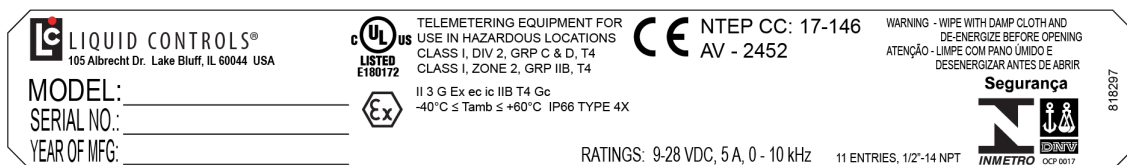
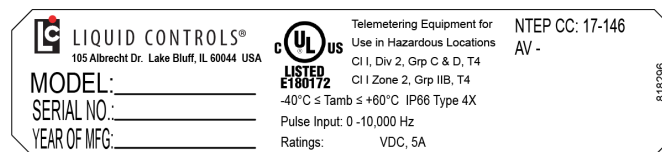



LIQUID CONTROLS®
105 Albrecht Drive, Lake Bluff, IL 60044 USA

BRAND: Avery-Hardoll®
MODEL: MASTERLOAD.iQ™
SERIAL NUMBER: XXXXXXXXX
YEAR OF MFG.: 2019
INPUT: 0-10 kHz, 9-28 VDC, 5A

 **E180172**

**TELEMETERING EQUIPMENT
FOR USE IN HAZARDOUS LOCATIONS:**
C1 I, Div. 2, Grp C & D, T4
C1 I, Zone 2, Grp IIB, T4
-40C < Tamb < +60 C IP66 Type 4X

NTEP CC: 17-146

Class I

- Potentially Explosive Gas/Vapor Atmospheres.

Division 2 and Zone II

- Gases and vapor are not normally present in an explosive concentration but may accidentally exist during abnormal operations.



(Explosive Atmospheres symbol)

- This equipment has been found to comply with the European Directive for Equipment For Potentially Explosive Atmospheres 2014/34/EU (ATEX), Certification Scheme for Explosive Atmospheres of INTERNATIONAL ELECTROTECHNICAL COMMISSION (IECEx) and

Brazil's Portaria 179, subject to the following condition of safe use: Wipe with damp cloth and de-energize before opening. Certificates (if applicable) are issued by DNV GL and are etched on the tag.

II

- Suitable for use in surface installations.

3G

- Equipment for explosive gas atmospheres, having a “high” level of protection, which is not a source of ignition in normal operation or during expected malfunctions.

Ex ec ic

- Explosion protection is provided by the increased safety method of protection with the “ec” level of protection.

GC

- Equipment Protection Level level, per IEC 60079-0, EN 60079-0, and ABNT NBR IEC 60079-0. Suitable for installations in Zone 2.

Grp C&D and Grp IIB

- Flammable/explosive Gas groups.

T4

- Temperature class for surface temperature limitations. T4 means that at the point at the rated maximum ambient temperature, the equipment will not generate temperature higher than 135 °C.

-40 °C ≤ Tamb ≤ 60 °C

- Safe limits of ambient temperature.

IP66

- Ingress protection: dust-tight and protected against powerful water jetting.

Type 4X

- The enclosure has been evaluated by UL for outdoor use to provide protection against water and dust and an increased level of protection against corrosion; and that will be undamaged by the external formation of ice.



- Indicates conformity with all applicable Directives for products sold within the European Economic Area.

Specifications

LCR.iQ [®] Specifications			
Enclosure			
Waterproof, corrosion resistant and dust-proof - meets IP66 and UL Type 4X requirements			
Display			
7 inch, 800 x 480 high-resolution, Full Color			
Temperature Range		Input Voltage	
-40°F (-40°C) to 140°F (60°C)		9-28 VDC	
Keypad			
LED Back-lit		Petroleum-resistant	
Non-conductive, UV resistant elastomer		Field Replaceable	
Communication		I/O	
RS232/485 Comm Ports	2	Solenoid Outputs (high current)	4
RS485 Dedicated Comm Ports	2	Programmable Digital Outputs	6
WiFi	Internal antenna	Digital Inputs	6
Bluetooth	Internal antenna	RTD Probe Input	1
Extended range antenna (externally mounted)	Optional accessory	Optical Sensor Input	1
4-20 mA inputs	1 expandable to 7	Scalable Pulse Output (Additive inj, display, PLC)	1
Processor & Storage			
Dual-Core Processor Speed		800 MHz	
Internal RAM		1GB	
Internal Storage		128MB Flash NAND 8GB eMMC Flash drive	
External Storage via Removable USB			

Check for a Good Ground

After installing the ground kits, use a multimeter to confirm that the seat and printer are both grounded properly.

Follow these steps to verify a good ground connection:

1. Turn OFF all accessories, including the dome light, to prevent other currents from distorting the reading.
2. Take a multimeter and measure the resistance between the brackets the two ground strap bolts are fastened to. Find a clean spot on the brackets without paint to use as contact points. Other bolts on the brackets are often suitable.

Turn off accessories

If the multimeter reads “MΩ” or “KΩ”, typically, one of the accessories is still on.

If the resistance is less than 3Ω , the system is grounded adequately. · If the resistance is still greater than 3Ω , check for proper metal to metal contact on both

ends of the ground strap. Clean any paint, dirt, or oxidation that may block the grounding point. If the resistance remains above 3Ω , attach the ground strap to a different ground point. Repeat the process until the ground resistance is below 3Ω .

Verify good contact

If operator receives a ESD discharge when leaving the seat, the ground strap is not installed correctly.

FCC Compliance



Unique Identifier: MASTERLOADx.iQ

Responsible Party:

Liquid Controls LLC

105 Albrecht Drive

Lake Bluff, IL 60044 USA

www.LCmeter.com

FCC Compliance Statement: This device complies with Part 15 of the FCC Rules. Operation is subject to the following two conditions: (1) This device may not cause harmful interference, and (2) this device must accept any interference received, including interference that may cause undesired operation.

This device contains FCC ID Z64-WL18DBMOD, IC: 451I-WL18DBMOD, and may optionally contain FCC ID MCQ-XBPS3B, IC: 1846A-XBPS3B (DIGI Module).

This equipment has been tested and found to comply with the limits for a Class B digital device, pursuant to part 15 of the FCC Rules. These limits are designed to provide reasonable protection against harmful interference in a residential installation. This equipment generates, uses, and can radiate radio frequency energy and, if not installed and used in accordance with the instructions, may cause harmful interference to radio communications. However, there is no guarantee that interference will not occur in a particular installation. If this equipment does cause harmful interference to radio or television reception, which can be determined by turning the equipment off and on, the user is encouraged to try to correct the interference by one or more of the following measures:

- Reorient or relocate the receiving antenna.
- Increase the separation between the equipment and receiver.
- Connect the equipment into an outlet on a circuit different from that to which the receiver is connected.
- Consult the dealer or an experienced radio/TV technician for help.

Any changes or modifications to this equipment, not expressly approved by Liquid Controls could void the user's authority to operate the equipment.

This device complies with the ISED Canada license-exempt RSS standard(s). Operation is subject to the following two conditions: (1) This device may not cause harmful interference, and (2) this device must accept any interference received, including interference that may cause undesired operation.

Cet appareil est conforme à la norme RSS exempte de licence d'ISED Canada. L'opération est sous réserve des deux conditions suivantes: (1) Cet appareil ne doit pas causer d'interférences; et (2) Cet appareil doit accepter toute interference fonctionnement indésirable de l'appareil CAN ICES-3(B)/NMB-3(B)

This device could automatically discontinue transmission in case of absence of information to transmit or operational failure. Note that this is not intended to prohibit transmission of control or signaling information or the use of repetitive codes where required by the technology.

The device for operation in the band 5150-5250 MHz is only for indoor use to reduce the potential for harmful interference to co-channel mobile satellite systems.

High power radars are allocated primary users (i.e. priority users) of the bands 5250-5350MHz and 5650-5850MHz and that these radars could cause interference and or damage to the Wi-Fi transceiver.

This equipment complies with the FCC/IC radiation exposure limits set forth for an uncontrolled environment.

Only antennas specified by Liquid Controls shall be used with this equipment. The antenna for this equipment shall be installed and operated to maintain a separation distance of 20 cm or greater between the antenna and any person.

The antenna for this equipment shall not be co-located with or operated in conjunction with any other antenna or transmitter. The antennas shall be installed and operated to maintain a separation distance of 20 cm or greater between any other radiating antenna.

The FCC ID and IC can also be viewed on the Register by pressing then then .

Dimensions - Panel Mount

FRONT VIEW

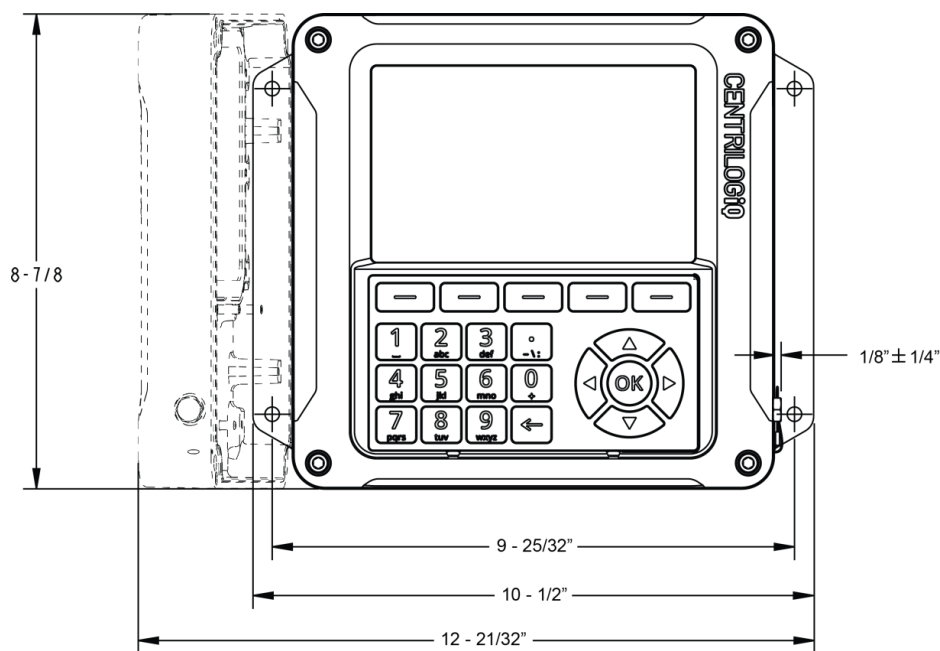

BACK VIEW

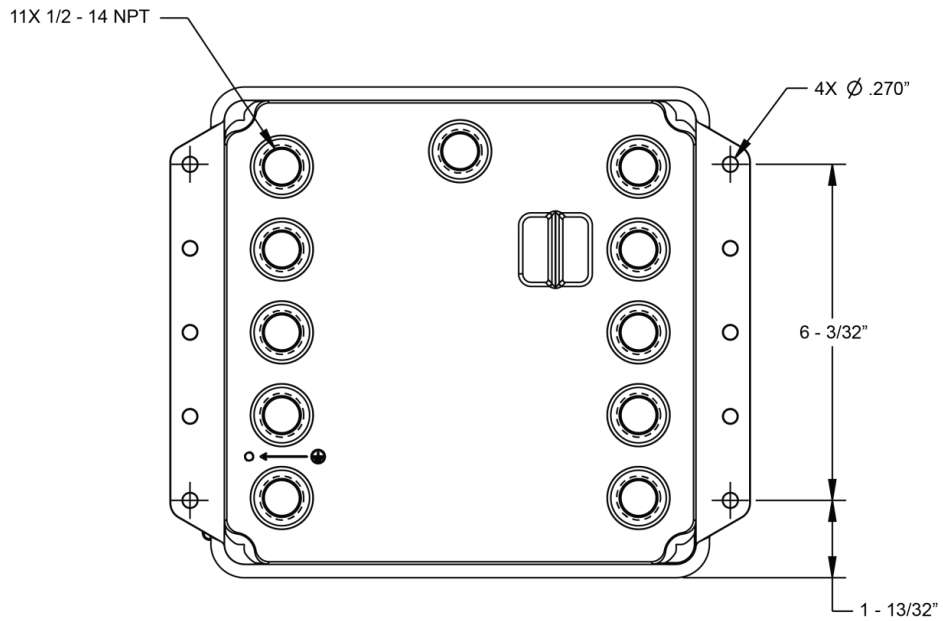

SIDE VIEW

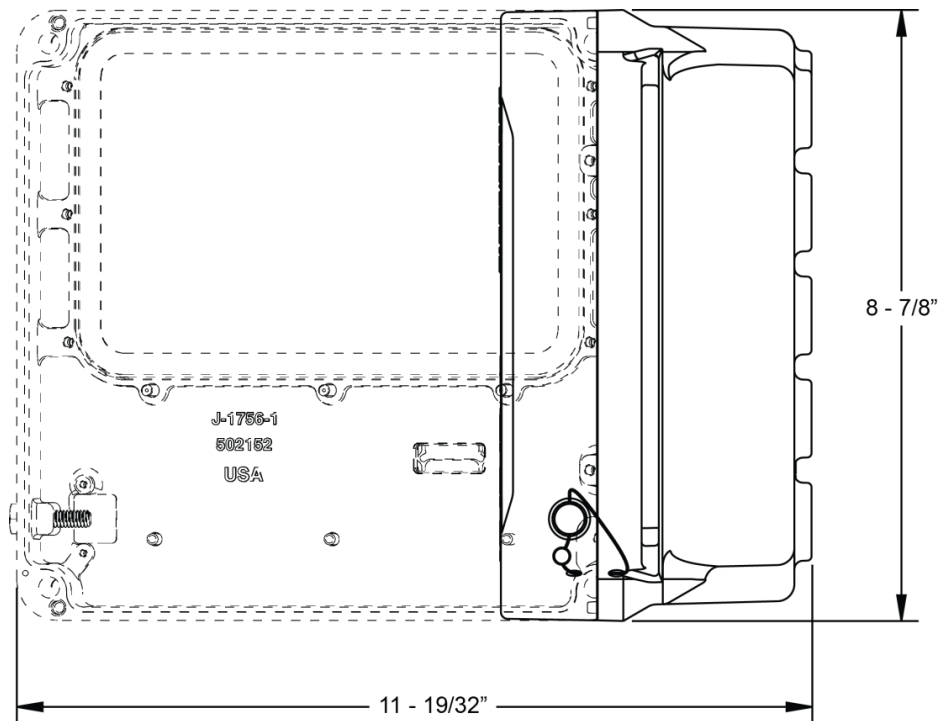

TOP VIEW

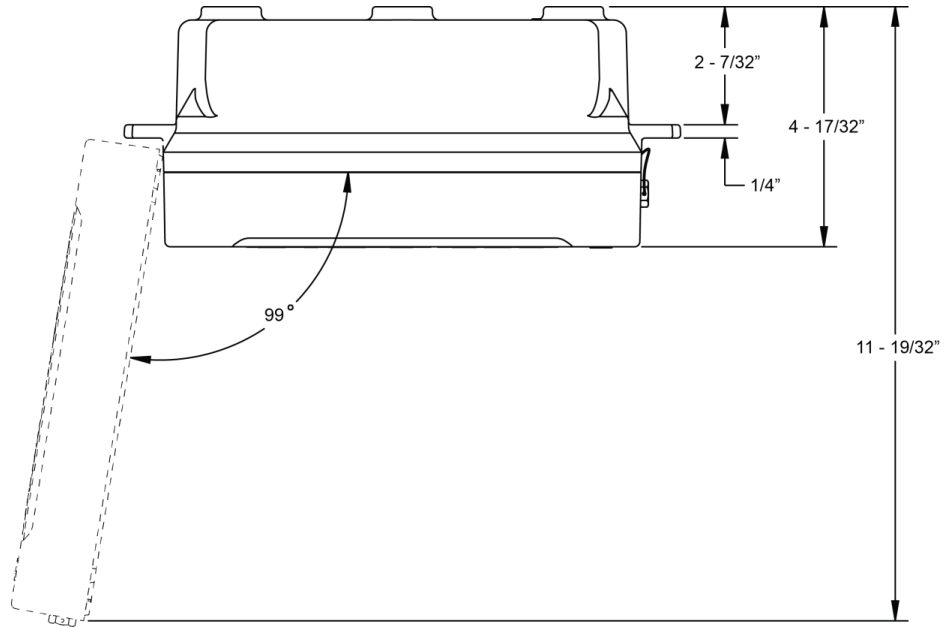

Dimensions - Meter Mount

Front View

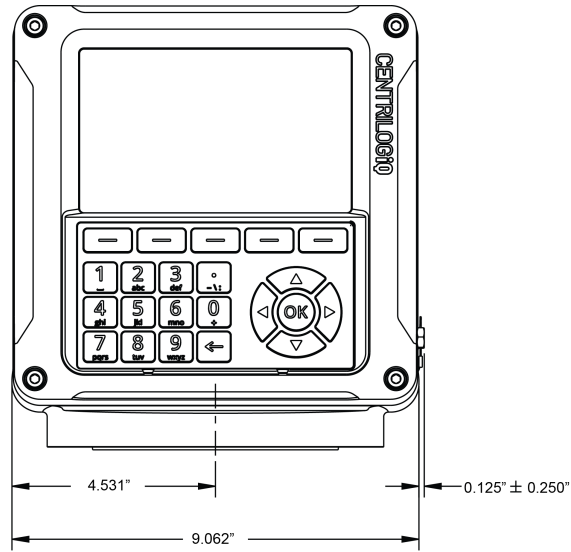

Back View

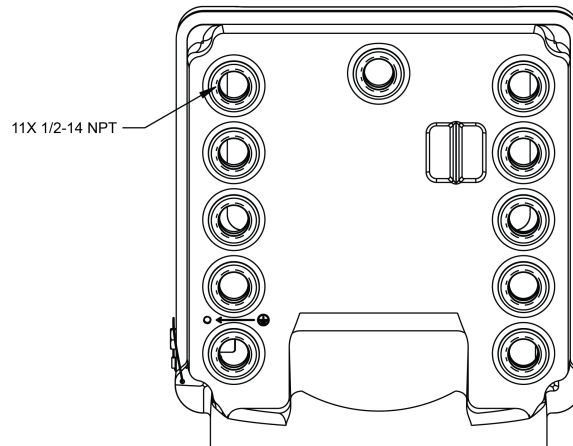

Side view

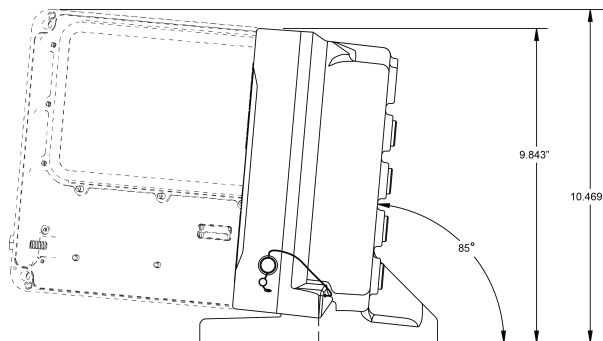

Top View

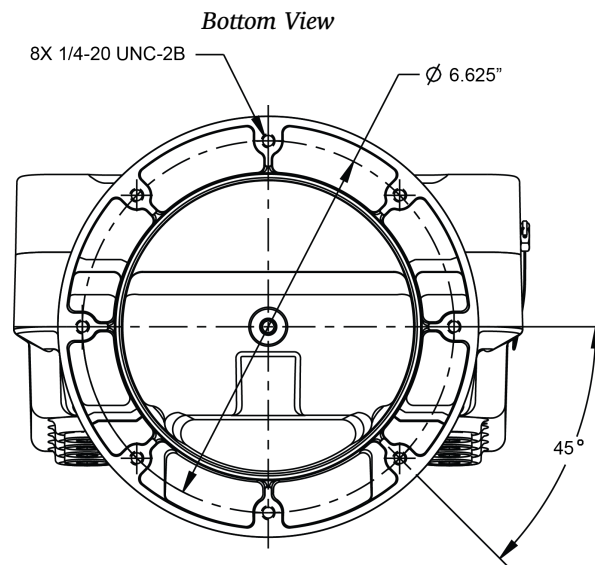
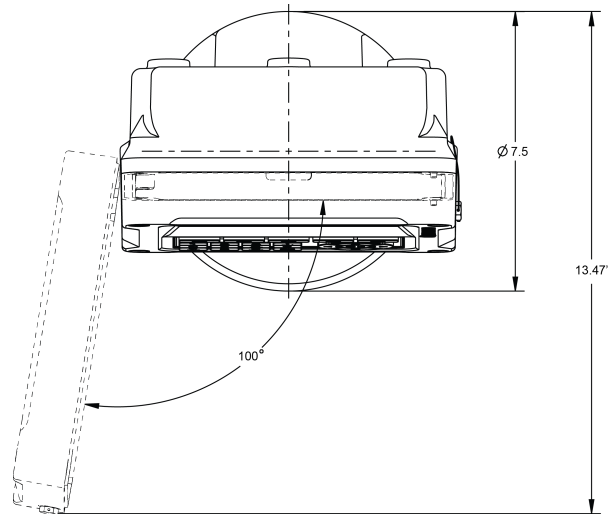





Installation

Check Each Shipment

Before installation, check your shipment against the packing list and ensure that no parts are missing. The packing list is inside the red information packet along with the Installation and Operation Manuals.





If the Register was ordered as part of a metering system, it may arrive mounted on the meter and pre-wired to peripheral equipment such as an ETVC probe, air eliminator, and valve.

Installation overview for Register ordered with meter system:

1. Ground truck seat cushion. See Ground Strap Kit  28 .
2. Install meter system onto truck or fixed installation. Refer to the Meter manual. 3. Run the data and power Cables from the Register to the truck cab or power supply. See [Routing Data and Power Cables](#)  41 .
4. Connect any additional components to the Register board.
5. Mount printer and connect printer data cable. See Printers  93 .
6. Connect the Register and the printer to power supply. See Power Supply  104 .
7. Setup and calibrate the Register.

If you are replacing an existing register, you must mount the register onto the meter and make the proper connections to all of the components.

Installation overview for a Register ordered without a meter system:

1. Ground truck seat cushion. See Ground Strap Kit  28 .
2. Mount the Register to the meter. See Mounting Overview  34 .
3. Run the Data and Power Cables from the Register to the truck cab or power supply. See [Routing Data and Power Cables](#)  41 .
4. Connect all components to the Register CPU board.
5. Mount printer and connect printer data cable. See Printers  93 .
6. Connect the Register and the printer to power supply. See Power Supply  104 .
7. Setup and calibrate the Register.

What this chapter covers

This chapter explains and details the mechanical installation of the Register and the temperature probe as well as the electrical and data installation of all components that connect to the Register. For additional installation information, refer to the manuals of the other components. All manuals are available at www.LCmeter.com .

Installation requirements will vary

Specific installation requirements will vary with the model of the truck, the physical layout of a fixed installation, the configuration of any existing metering equipment, the options selected, and the type of fluid being metered.

Ground Strap Kit

All seat cushions are grounded in a similar manner. The illustrations below detail the following instructions for grounding three typical types of truck seats.

ESD Precaution
Install the Ground Strap Kit before installing the register.

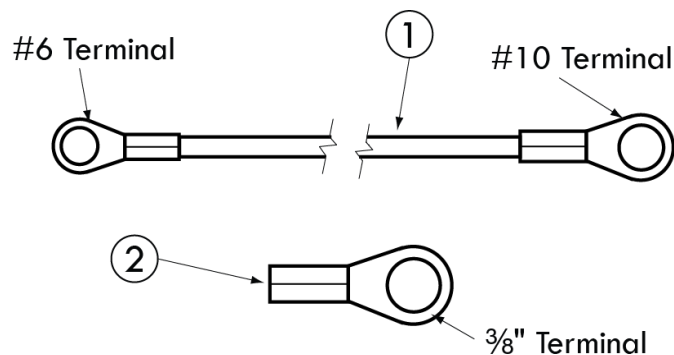

Follow these steps to ground a truck seat:

1. Identify any adjustable, shock absorbing seat in the truck cab. These seats will typically have pivot points, hinges, or other mechanical design features that make seat adjustments possible.

Grounded Passenger Seats

Some truck seats, typically passenger seats, are not adjustable and do not nécessite une mise à la terre.

2. Repérez une vis ou un trou existant à l'arrière du cadre du siège, près du plancher de la cabine. Si un trou ou une vis n'existe pas déjà, percez un trou de 9/32" dans le cadre du siège.
3. Fixez une extrémité de la tresse de mise à la terre au support du cadre du siège à l'aide de la rondelle frein, de la rondelle plate et de l'écrou fournis.

Assurez une Bonne Mise à la Terre

Remove any dirt or oxidation from the ground strap contact point. Lock washers should penetrate any paint to ensure a good electrical connection.

4. Find an existing screw or hole, or drill a 9/32" hole, in the part of the seat frame—above all pivots and adjustments—that is attached directly to the seat cushion. Make sure that there are no intervening pivot points, guides, adjustment mechanisms, etc., which could interfere with the ground path between the seat cushion and the ground strap.
 - If the seat cushion has a wooden base, use a wood screw and washer to attach the strap lug to the bottom of the seat at a point where the seat fabric is attached to the wood. There must be good contact between the seat fabric and ground strap lug.
5. Use the wire ties provided with the kit and tie off the strap so that it doesn't interfere with the movement of the seat and is clear of traffic areas in the cab.
6. Check the strap for a good ground connection (see below).

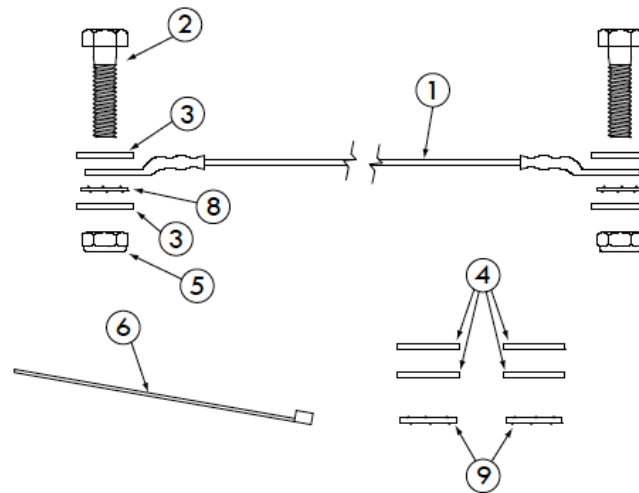

LectroCount Ground Strap Kit - 82185

Attach Ground Strap

Typical Adjustable Truck Seats

The diagrams below demonstrate how to attach the ground strap to typical truck seats.

Air Cushion Seat - Adjustable for Height

(Bostrom 914 Series, National 2000 Series, or equivalent)

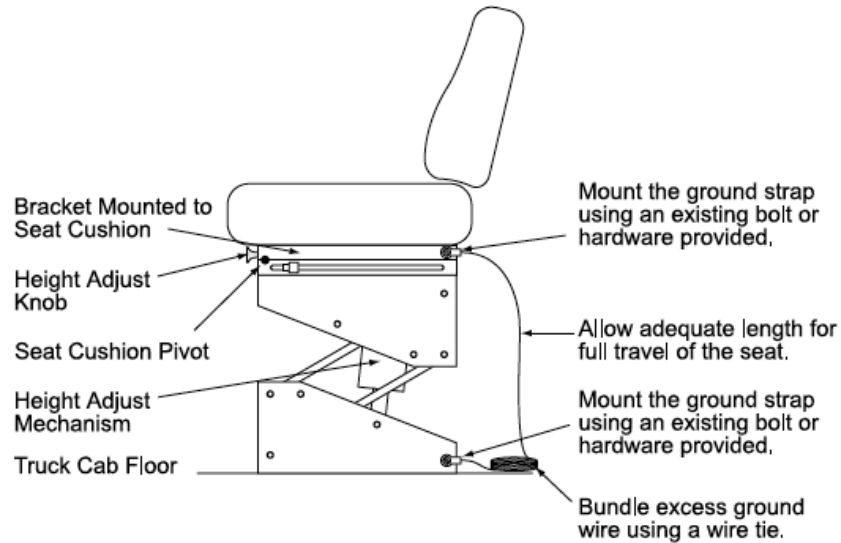

Air Cushion Seat - Adjustable for Height

(Dura-Form or equivalent)

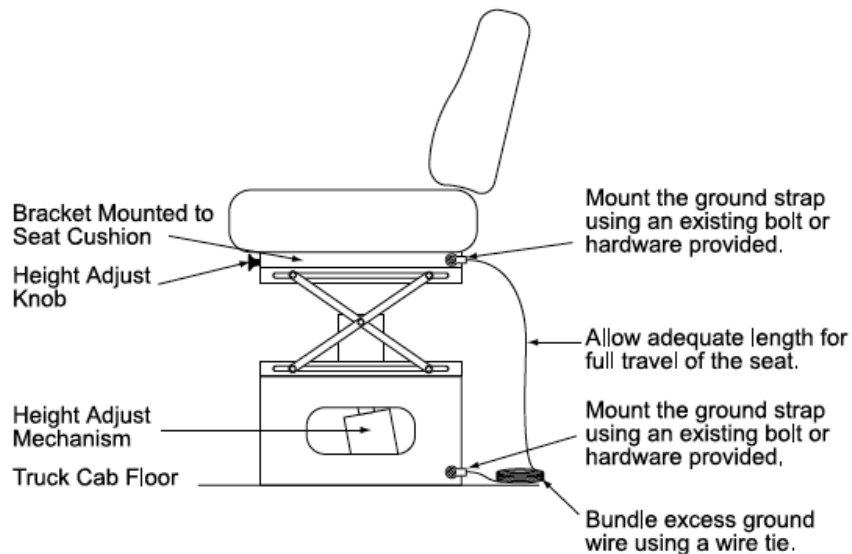

Bench Seats - Adjustable for Distance to the Steering Wheel

(Manufacturer Standard or equivalent)

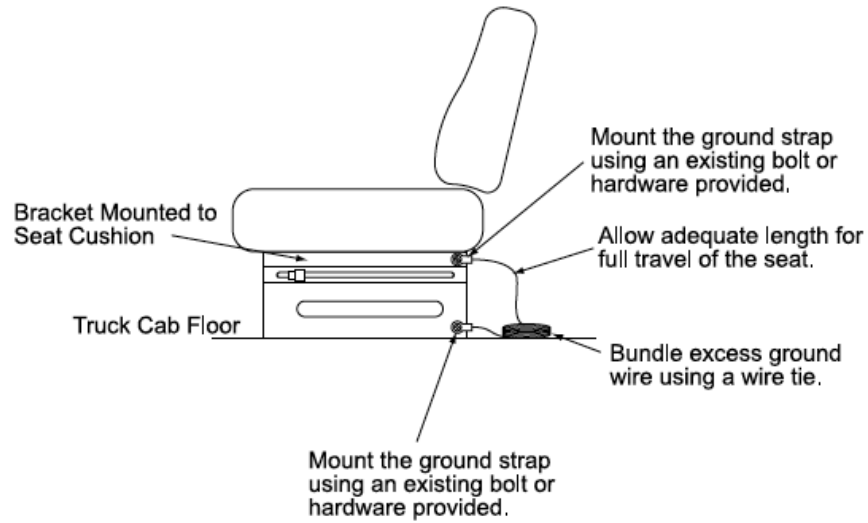

Use of Intrinsically Safe Sensors



WARNING

When wiring an intrinsically safe sensor to the register, follow the following precautions:

- When placing an intrinsically safe sensor in Zone 1 or Zone 2 area, use certified intrinsically safe barrier suitable for the installation.
- Use installation methods in accordance with IEC 60079-14 and its regional equivalents.

If available, follow sensor manufacturer instructions when selecting the barrier.

- If you must locate the barrier in Zone 1 or Zone 2, use appropriately certified enclosure to house the barrier.
- Ensure that the addition of the barrier does not affect the functional performance of the sensor.

Check for a Good Ground

After installing the ground kits, use a multimeter to confirm that the seat and printer are both grounded properly.

Follow these steps to verify a good ground connection:

1. Turn OFF all accessories, including the dome light, to prevent other currents from distorting the reading.
2. Take a multimeter and measure the resistance between the brackets the two ground strap bolts are fastened to. Find a clean spot on the brackets without paint to use as contact points. Other bolts on the brackets are often suitable.

Turn Off Accessories

If the multimeter reads “M Ω ” or “K Ω ”, typically, one of the accessories is still on

If the resistance is less than 3 Ω , the system is grounded adequately. · If the resistance is still greater than 3 Ω , check for proper metal to metal contact on both

ends of the ground strap. Clean any paint, dirt, or oxidation that may block the grounding point. If the resistance remains above 3 Ω , attach the ground strap to a different ground point. Repeat the process until the ground resistance is below 3 Ω .

Verify good contact

If operator receives a ESD discharge when leaving the seat, the ground strap is not installed correctly.

Voltage and Ground Short Verification

1. Verify that supply voltage is not shorted to ground on the Cart/Truck between the Power Supply voltage and Chassis .

To do this:

1. Perform a visual inspection of the wiring from the Power Source to end of termination inside the LCR.iQ to ensure that no exposed wires due to a break in the protective insulation.

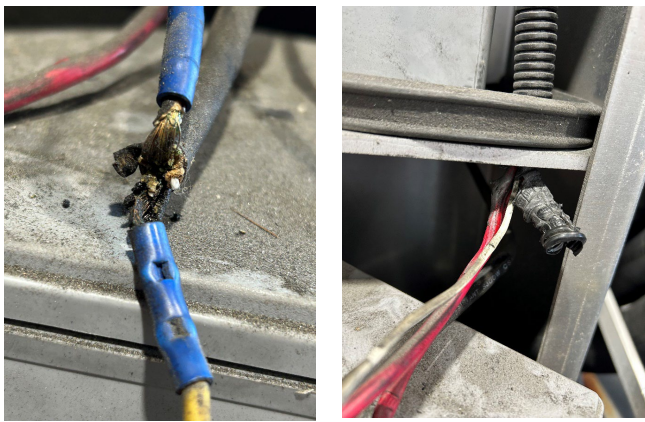

Fig. 1 - Examples of damaged wiring insulation

2. Verify that the Power Source and Chassis are not shorted together.

To do this:

- Disconnect the Positive Cable from the battery or Power Source (+ 12V/24V).
- Set the multimeter to Continuity mode.
- Probe both the Power Source cable and the Chassis of the cart/truck to ensure they are not shorted to each other.

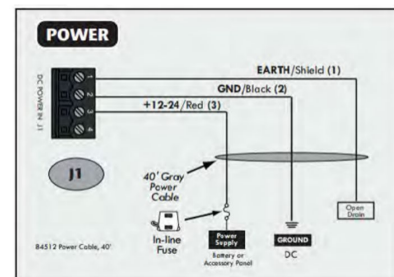

Fig. 2 - Wiring diagram for power supply

3. If the LCR.iQ is already installed on the cart/truck, proceed by measuring the voltage between J1 pin 1 (EARTH) and J1 pin 3 (+VBAT) on the J1 terminal block. This voltage should equal the Power Supply Voltage. If the measured voltage is zero or near-zero volts, the chassis is "hot" and is shorted to the Power Supply Voltage external to the register.

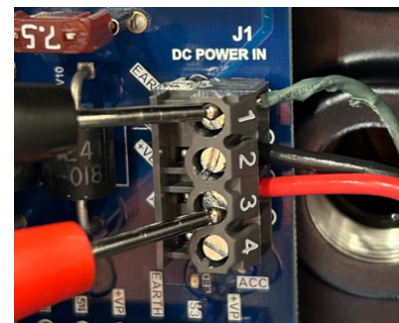

Fig. 3 - Wiring for power supply

Mounting Overview

The Register is available in two separate mounting options: meter mount and panel mount .

The Register can be mounted directly onto a flow meter; however, it may also be mounted away from the meter in a more ergonomic or advantageous position, on a control panel or control pedestal. If the meter is equipped with an external POD pulser, the Register can be mounted up to 1000 feet (304 meters) away from the meter (actual distance depends on pulser specifications and wire type).

- The meter mount design consists of an enclosure base with a round mounting surface that mates perfectly with standard LC register adapter bracket or industry standard register mount and can be mounted in 45° increments.
- The panel mount design consists of an enclosure base with mounting tabs to allow the register to be conveniently mounted on a flat panel from the front or rear of the panel for a very clean and wire-free installation from the operator's point of view.

Meter Mount Housing



Panel Mount Housing



Adapters are available for other PD meters such as Neptune (PNs 81364, 82641, 82642), FMC Smith (PN 81370), and Brooks/Brodie (PN 81800) meters. Each kit includes installation instructions.

Tips for mounting a Register

- Leave the cover assembly fastened to the base to protect the internal components.
- Ensure that the vertical drive shaft from the meter is attached to the pulser drive shafts.
- Before securing the Register to the meter or mounting bracket, ensure that the counter is visible and the keypad and calibration screw can be easily operated.



WARNING

Relieving Internal Pressure

All internal pressure must be relieved to zero pressure before disassembly or inspection of the strainer, vapor eliminator, any valves in the system, the packing gland, and the front or rear covers.

WARNING: Serious injury or death from fire or explosion could result in performing maintenance on an improperly depressurized and evacuated system.

Relieving Internal Pressure Procedure for LPG and NH 3 Meters

Follow these steps:

1. Close the belly valve of the supply tank.
2. Close the valve on the vapor return line.
3. Close the manual valve in the supply line on the inlet side of the meter. If no manual valve exists on the inlet side, consult the truck manufacturer for procedures to depressurize the system.

4. Slowly open the valve/nozzle at the end of the supply line.
5. After product has bled off, close the valve/nozzle at the end of the supply line.
6. Slowly crack the fitting on top of the differential valve to relieve product pressure in the system. Product will drain from the meter system.
7. As product is bleeding from the differential valve, slowly reopen and close the valve/nozzle on the discharge line. Repeat this step until the product stops draining from the differential valve and discharge line valve/nozzle.
8. Leave the discharge line valve/nozzle open while working on the system.



APPLY Anti-seize

Always apply anti-seize to all bolt threads to ensure easy removal at a later date.

Mounting the Register

Mounting Bolt Pattern

The Register base housing contains eight bolt holes in an industry standard bolt pattern. This design allows for horizontal rotation of the housing in 45° increments to conveniently mount the register in various orientations. The holes are ½" deep and take ¼"-20 screws.

If the installation requires that you fabricate a bracket, refer to the drawing below.

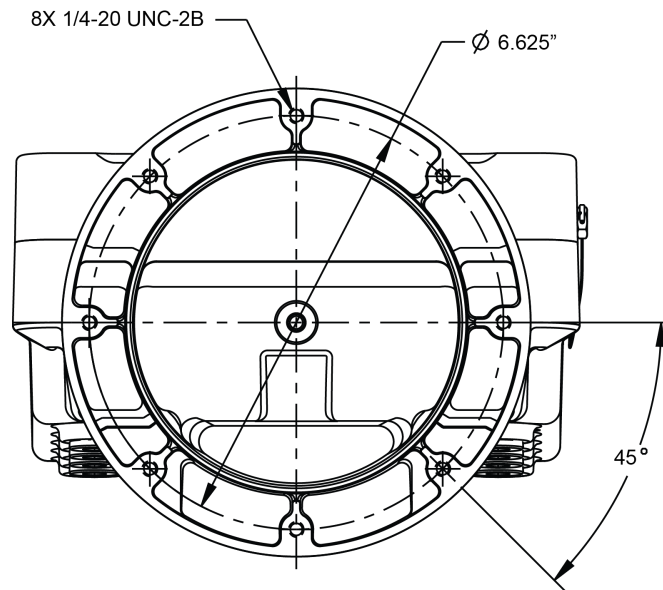

Installing the Register on existing LC meter installations

Remove Existing Registration Equipment

Follow these steps:

1. Depressurize the meter completely. See the Warnings in Mounting Overview 34
2. Remove the four bolts on the bottom that fasten the register to the meter. 3. If replacing a mechanical register, remove the adjuster from the meter. 4. If the meter has a Temperature Volume Compensator (TVC), remove it as well.

Mount the Register

Follow these steps:

1. Place the end of the shaft adapter on the pulser drive shaft located on the bottom of the register.
2. Place the cotter pin through the hole, and bend open the ends of the cotter pin. 3. Lower the register onto the meter, and insert the shaft adapter onto the hex shaft on the meter.
4. Securely bolt down the register.

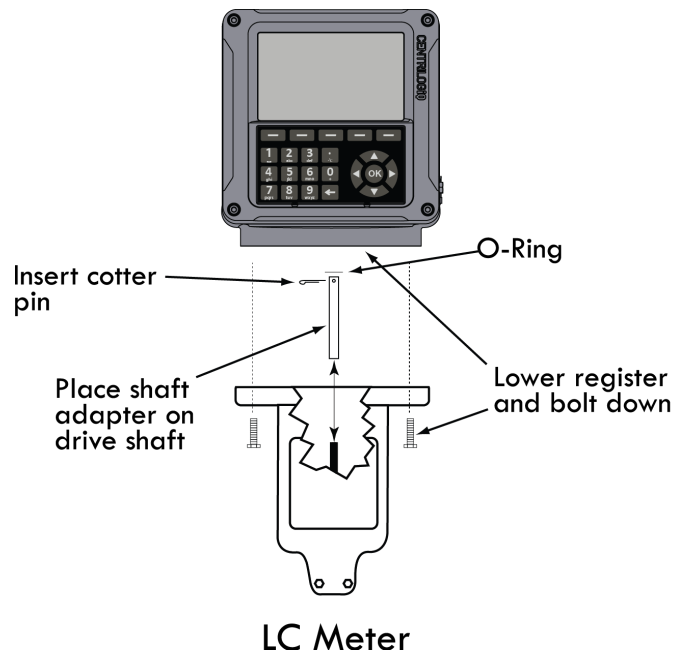

Apply Anti-seize

Apply anti-seize to all bolt threads to ensure easy removal at a later date.

Neptune Meters

Remove Existing Registration Equipment

Follow these steps:

1. Depressurize the meter completely. See the Warnings in Mounting Overview
2. Remove the mechanical register from the meter.
3. Leave the star-shaped gear and the two square-head studs.
4. Remove the bellows from the front of the meter.
5. Remove the compensator.



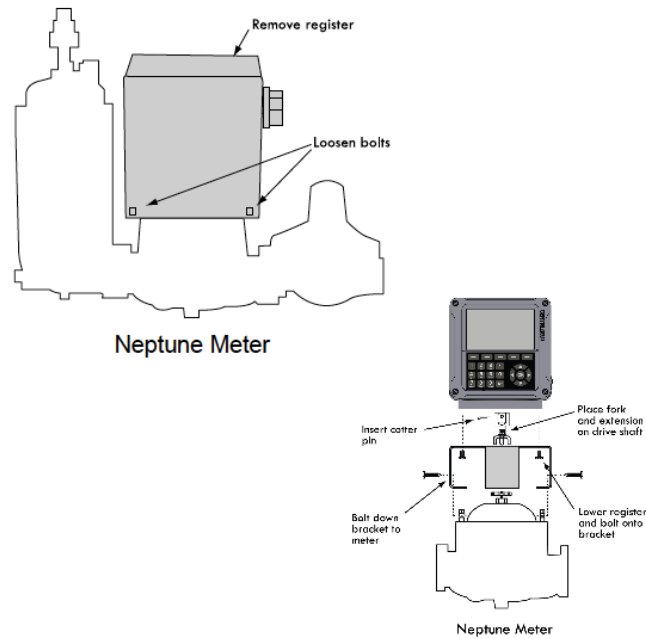

Mount the Register

Follow these steps:

1. Install the drive fork and extension piece (pictured below) on the pulser drive shaft located on the bottom of the Register.

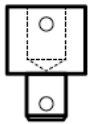

Neptune Drive Shaft
Extension

2. Install the bracket on the meter, and fasten with the bolts provided in the kit. 3. Lower the Register on to the bracket, and securely fasten using the four bolts ($\frac{1}{4}$ " x $\frac{3}{4}$ "") provided.

Star Gear and Drive Fork

When the register is lowered onto a Neptune meter, make sure the drive fork is not pressed against the star gear on the meter. There must be a small gap between these two parts. To lower the star gear, loosen the set screw on the side of the star gear. Failure to do so will eventually damage the internal pulser and/or the meter gear train.

APPLY Anti-seize

Apply anti-seize to all bolt threads to ensure easy removal at a later date.

Mount the Register on previously temperature compensated Neptune meters

Follow these steps:

1. Place the shaft adapter on the pulser drive shaft under the Register. 2. Place the cotter pin through the hole, and bend open the ends of the cotter pin. 3. Pass the other end of the shaft adapter through the flange assembly and the weather plate.
4. Loosely bolt to register.
5. Place the drive fork and extension piece on the shaft using two more cotter pins. 6. Bolt the flange to the meter and tighten all bolts.

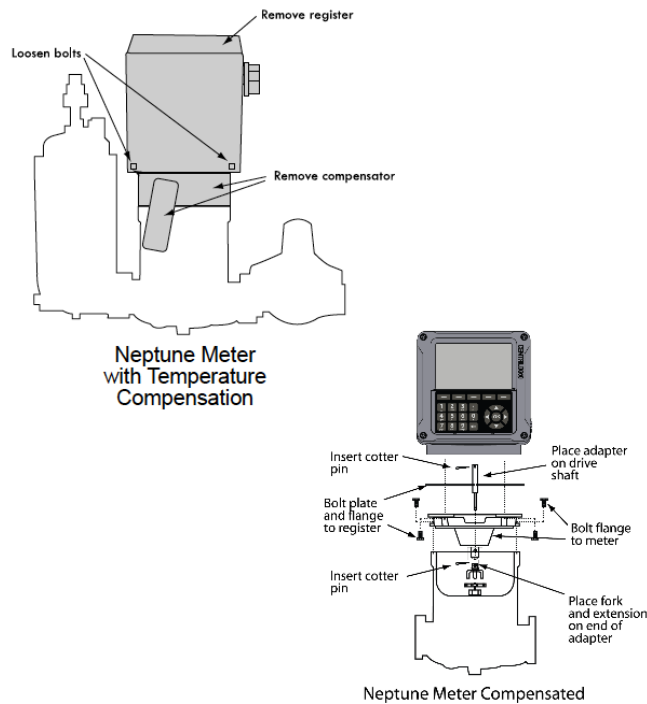

Installation kits 82641 (E-26 series) & 82642 (E-36 series) are specifically designed for previously temperature compensated Neptune meters.

Routing the Data and Power Cables

Data and Power Cables

The Register shipment typically includes a gray 50-foot power cable and a 50-foot black data cable, pre-wired to terminal blocks on the Register CPU board. On typical truck installations, the cables must be routed from the back of the truck—where the Register is installed—to the front of the truck, where the accessory panel is and the printer is typically installed. The black data cable connects to the printer, typically mounted in the truck cab. The gray power cable hooks up to a power source. During installation, follow these guidelines and ensure the cables remain undamaged.

During installation, follow these guidelines and ensure the cables remain undamaged.



Guidelines for routing the data and power cables on the outside of the truck

- LC recommends that both cables be run through 1/2" automotive plastic corrugated split loom or through flexible liquid-tight conduit for protection.
- Make sure the loom or conduit runs down the inside edge of the trucks frame rail and fasten every 2' with cable ties.
- Install rubber grommets to protect the cables where they pass through the cab wall, meter box, etc.
- Keep the cables away from heat sources such as the engine exhaust, manifold, exhaust pipe, mufflers, etc.
- Keep cables away from moving suspension components and other moving truck components.
- If the cables are shortened, ensure that you use the proper tool for stripping off the insulation on the cables.
- Ensure that all cabling and wiring connections are connected to the proper terminal locations.

Guidelines for routing the data and power cables inside the cab

- Before you begin, layout positions for the component and pathways for the cable.
- Ensure that the printer and the wires will not obstruct other vehicle components.
- Keep cable pathways away from heavy traffic areas and locations where they may be vulnerable to damage.

- Remember to provide plenty of room around the components, so the cables can be easily connected.

Avoid installing the cable where it will be exposed to excessive flexing. · Ensure that cables are not pulled too tight in areas that will move. For example, when

wiring cab-over trucks, leave enough slack so the cab can be tilted without damaging the cable.

- Ensure cables are not fastened to adjustable seats.

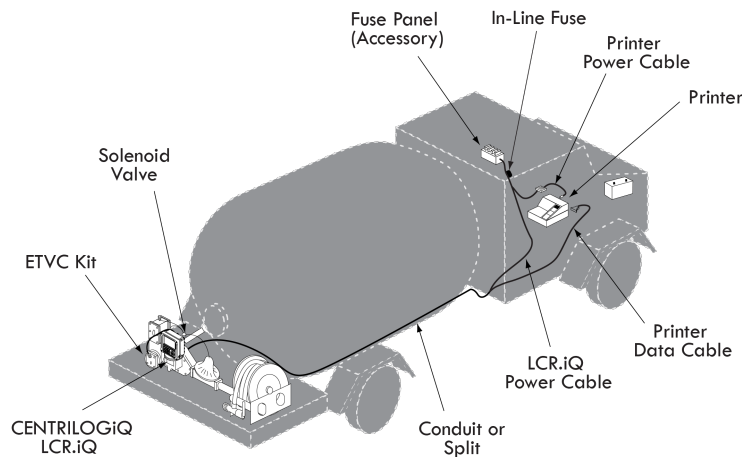

ETVC Installation

Electronic Temperature Volume Compensation (ETVC) Installation

When ordered as part of a meter system with a Register, the ETVC kit is typically bolted onto the strainer and wired to the Register at the factory. ETVC kits can also be ordered and retrofit onto meter systems already in service. Kits are specified according to meter size and application and are all installed in the same manner. For meter systems that do not include an LC supplied Strainer mounting kit, Liquid Controls also offers an ETVC kit for pipe mount.

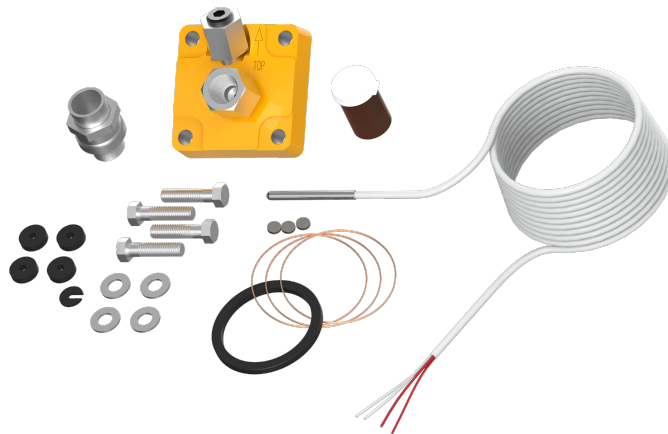

A conduit kit (PN 81024)—with a 30-inch length of weatherproof flexible conduit—is available from Liquid Controls to provide protection for the RTD temperature probe wire between the strainer cover and the Register.



Follow these steps to install the ETVC kit:

1. Depressurize the meter completely. See the Warnings in Mounting Overview
2. Remove the old strainer cover.
3. Clean the strainer basket and replace it into the housing.
4. Lightly coat the new cover gasket (included with the ETVC kit) with lubricant. **DO NOT** use the included copper grease.
5. Fit the new cover gasket into the strainer cover groove.



6. Bolt the strainer cover in place. Make sure the weights & measures Thermowell port is at the top of the cover.
7. Assemble the Thermowell kit.

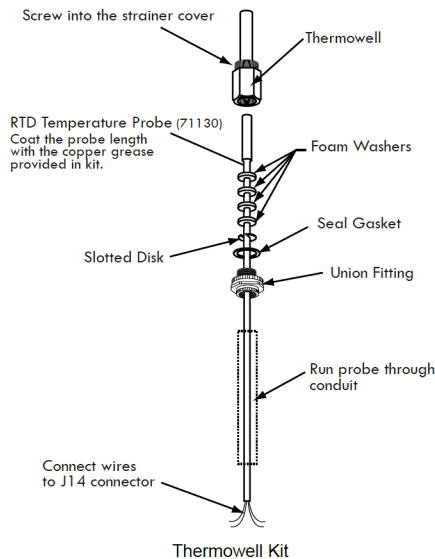

8. Coat the entire probe length with the copper grease provided. Insert and recoat the probe 2 or 3 times to provide a uniform coating inside the Thermowell and to ensure proper heat transfer from the liquid to the probe.
9. Connect the assembled Thermowell to the fitting in the middle of the strainer cover. The angled fitting at the top of the cover is for weights & measures purposes. See Step 6 above.
10. Connect the conduit to a 1/2" NPT port on the back of the Register using the elbow fittings provided with the conduit kit (PN 81024). Be sure to use thread sealant on NPT threads.
11. Wire the temperature probe to the Register internal board on connector J15. See the circuit board diagrams below.

Disconnect Power

Disconnect the power before working with the CPU board.

Diagram for Rev E boards

Diagram for Rev J or later boards

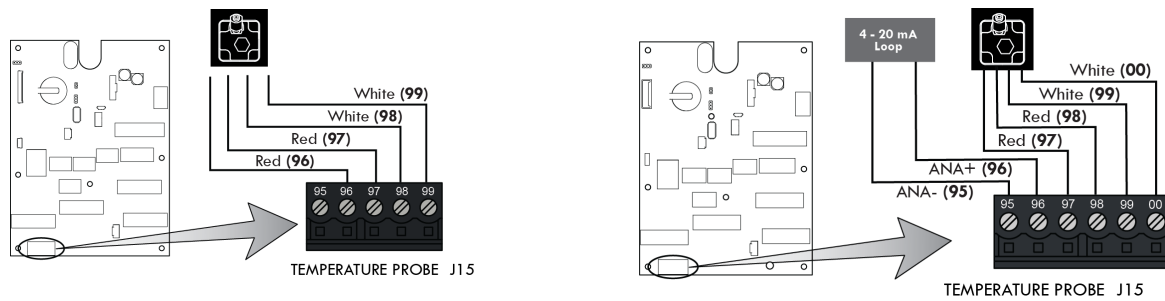

Input and Output Setup

Digital Inputs

LCR.iQ digital inputs are *active-low*, which means the input signal is normally high unless it is forced low by an external device.

Each digital input is pulled high through a 2200-ohm resistor to supply voltage.

Devices connected to an LCR.iQ digital input must be able to sink the following current:

- 18 mA for 24-volt electrical systems
- 7.3 mA for 12-volt electrical systems

Examples of external devices include:

- Input pulser channels (pulse train signals, up to 10 kHz).
- Optical Air Eliminator sensor (output low when no air present). Any device which sets an output to ground, such as a relay or solid-state switch.

Solid-state switches may be either of the "totem-pole" or "open drain" type.

**WARNING**

Although the digital input signal lines contain protection against high-voltage transients, an active signal should not exceed the main supply voltage value.

Digital Input 7

Digital Input 7 is reserved for low-speed signals as used by Liquid Controls optical Air/Vapor eliminator.

Digital Outputs

LCR.iQ digital outputs are ‘active-low open drain’, which means the output signal is normally high. The digital outputs provide a path to ground for devices powered by the systems supply voltage.

Each digital output is pulled high by an internal resistor. This provides a method to check for proper operation of a digital output with no load attached. Connecting a voltmeter to the desired port and ground will verify proper operation of the digital output:

- If the voltage is high (vehicle battery), the output is inactive.
- If the voltage is low (less than 1 volt), the output is active.

Each digital output contains a diode clamp, so connecting inductive loads (such as relay coils or solenoids) will not damage the register electronics.

Each digital output is also protected against accidental faults to battery or ground. If a fault occurs, the output shuts down automatically. The output resumes normal operation after clearing the fault.

Examples of digital outputs include:

- Calibrated Pulse Output – Select the desired digital output line (D-OUT-1 through D-OUT-6) and desired scale factor.

- Liquid Controls XL Display (E1615) – Set two of the digital outputs (D-OUT-1 through D-OUT-6) to LC Display A and LC Display B when utilizing the XL Displays digital signal. Both channels A and B are required for operation.
- Relay coil – to control high-current loads.

Solenoid Outputs

LCR.iQ solenoid outputs are *active-low open drain*, which means the output signal is normally high. The solenoid outputs provide a path to ground for devices powered by the systems supply voltage.

Each solenoid output is pulled high by an internal resistor. This provides a method to check for proper operation of a solenoid output with no load attached. Connecting a voltmeter to the desired port and ground will verify proper operation of the digital output:

- If the voltage is high (vehicle battery), the output is inactive.
- If the voltage is low (less than 1 volt), the output is active.

Each digital output contains a diode clamp, so connecting inductive loads (such as relay coils or solenoids) will not damage the register electronics.

Each solenoid output is also protected against accidental faults to battery or ground. If a fault occurs, the output shuts down automatically. The output resumes normal operation after clearing the fault.

Examples of solenoid outputs include:

- Single stage and Two stage valve control solenoids
- Vapor purge valve solenoids for optical Air Elimination

Analog Input (LCR.iQ)

The LCR.iQ register has one 4-20 mA current loop input. This input can accommodate loop powered sensors, or sensors that require separate DC power connections.

Examples of analog input sensors include:

- Water detection in fuel
- Tank level (Near Future)

LCR.iQ Analog Input – Loop Powered Sensor using Onboard DC Power

The diagram shows how to connect a loop-powered sensor to a 4-20 mA analog input channel, using the voltage available from the register power bus.

Use the Digital Output terminal block to obtain DC power for the sensor. Voltage on the + VP terminal will be the same as the register power supply voltage. See the diagram below. Refer to the sensor manufacturer's installation manual for specific connection details.



WARNING

Do not connect a sensor rated for +12V to a register operating from a +24 V power supply. Use a separate +12V DC power supply to properly operate the sensor.

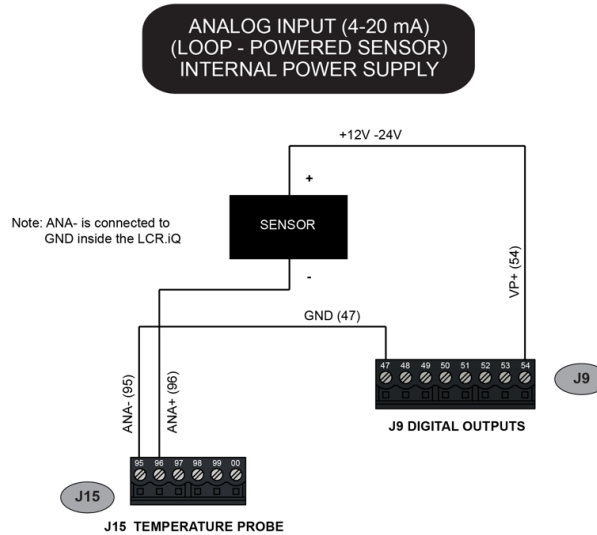

LCR.iQ Analog Input- Loop-Powered Sensor with External Power Supply

The diagram below shows how to connect a loop-powered sensor to a 4-20 mA analog input channel, using an external DC power supply. Refer to the sensor manufacturer's installation manual for specific connection details.

Power Supply Rating

Use an external DC power supply with the proper rating for the sensor. Connect the ground wire as shown in the diagram below to make a stable voltage reference.

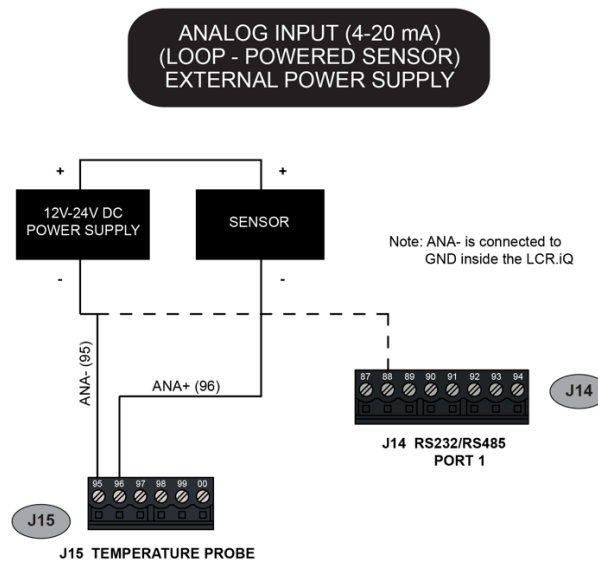

Refer to the sensor manufacturer's installation manual for specific connection details.

LCR.iQ Analog Input – 3-Wire Sensor

The diagram shows how to connect a three-wire sensor to a 4-20 mA analog input channel, with DC power provided by the register.

Use the Digital Output terminal block to obtain DC power for the sensor. Voltage on the + VP terminal will be the same as the register power supply voltage. Refer to the sensor manufacturer's installation manual for specific connection details.

**WARNING**

Do not connect a sensor rated for +12V to a register operating from a +24 V power supply. Use a separate +12V DC power supply to properly operate the sensor.

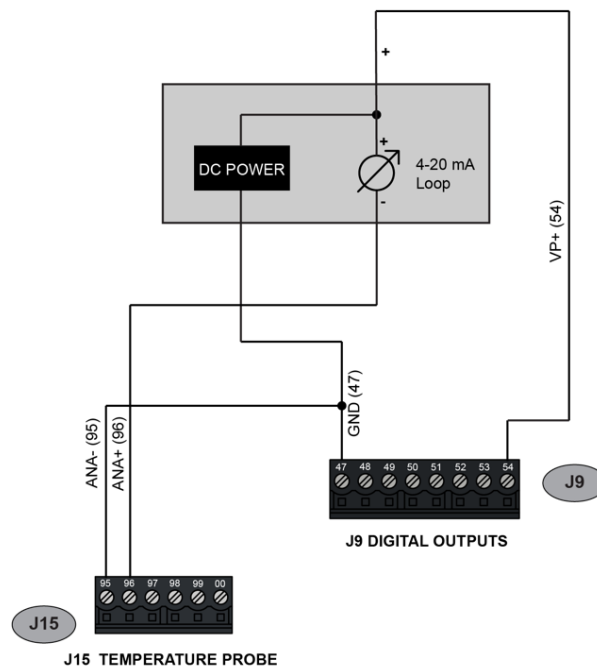
**ANALOG INPUT (4-20 mA)
3-WIRE SENSOR**

Refer to the sensor manufacturer's installation manual for specific connection details.

LCR.iQ Analog Input – 4-Wire Sensor

The diagram shows how to connect a four-wire sensor to a 4-20 mA analog input channel, with DC power provided by the register.

Use the Digital Output terminal block to obtain DC power for the sensor. Voltage on the +VP terminal will be the same as the register power supply voltage. Refer to the sensor manufacturer's installation manual for specific connection details.



WARNING

Do not connect a sensor rated for +12V to a register operating from a +24 V power supply. Use a separate +12V DC power supply to properly operate the sensor.

ANALOG INPUT (4-20 mA) 4-WIRE SENSOR

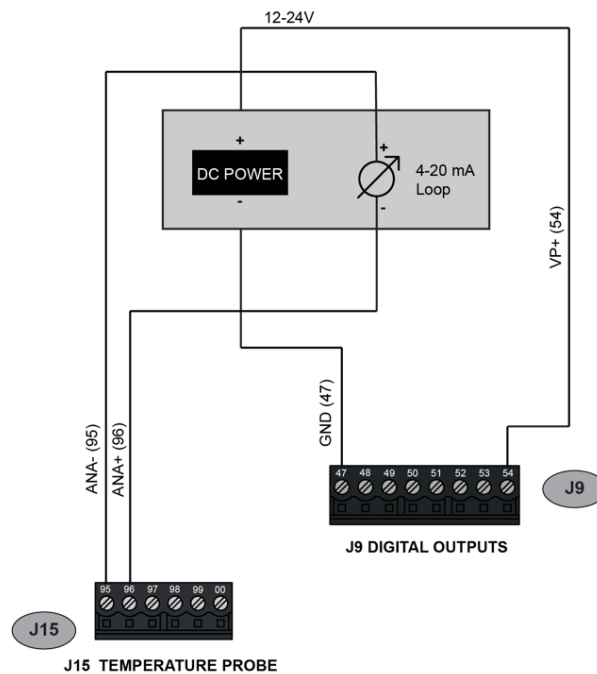

Refer to the sensor manufacturer's installation manual for specific connection details.

SENSEiQ™ Expansion Board

Analog Inputs with SENSEiQ™ I/O Expansion Board

The SENSEiQ board has six 4-20 mA current loop inputs. These inputs can accommodate loop powered sensors—or sensors that require separate DC power connections.

Examples of analog input sensors include:

- Water detection sensors
- Tank level sensors

SENSEiQ™ Analog Input – Loop Powered Sensor Using Onboard DC

Power

The diagram below shows how to connect a loop-powered sensor to a 4-20 mA analog input channel, using the voltage available from the register power bus.

Use the Digital Output terminal block to obtain DC power for the sensor. Voltage on the + VP terminal will be the same as the register power supply voltage.

For specific connection details, refer to installation manual from the sensor manufacturer.

Use a 12V power supply

Do not connect a sensor rated for +12V to a register operating from a +24 V power supply. Use a separate +12V DC power supply to properly operate the sensor.

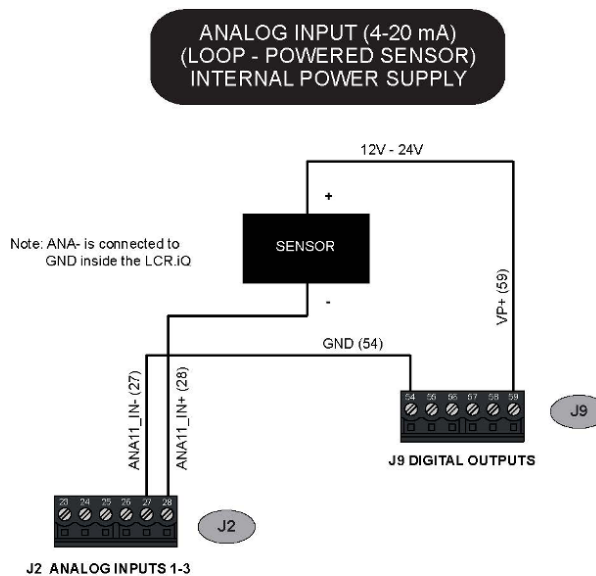

Refer to the sensor manufacturer's installation manual for specific connection details.

SENSEiQ™ Analog Input- Loop-Powered Sensor with External Power

Supply:

The diagram below shows how to connect a loop- powered sensor to a 4-20 mA analog input channel, using an external DC power supply.

For specific connection details, refer to installation manual from the sensor manufacturer.

NOTES

1. Use an external DC power supply with the proper rating for the sensor.
2. Connect the ground wire as shown to make a stable voltage reference.

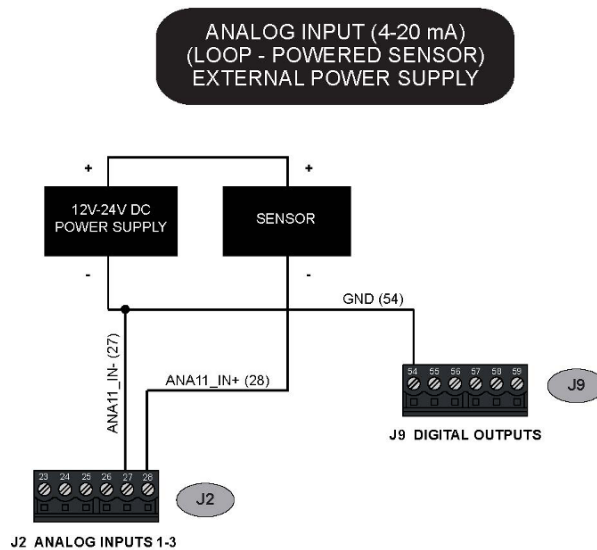

Refer to the sensor manufacturer's installation manual for specific connection details.

SENSEiQ™ Analog Input – 3-wire sensor

The diagram below shows how to connect a 3-wire sensor to a 4-20 mA analog input channel, using the voltage available from the register power bus.

Use the Digital Output terminal block to obtain DC power for the sensor. Voltage on the + VP terminal will be the same as the register power supply voltage.

For specific connection details, refer to installation manual from the sensor manufacturer.

Use a 12V power supply

Do not connect a sensor rated for +12V to a register operating from a +24 V power supply. Use a separate +12V DC power supply to properly operate the sensor.

ANALOG INPUT (4-20 mA) 3-WIRE SENSOR

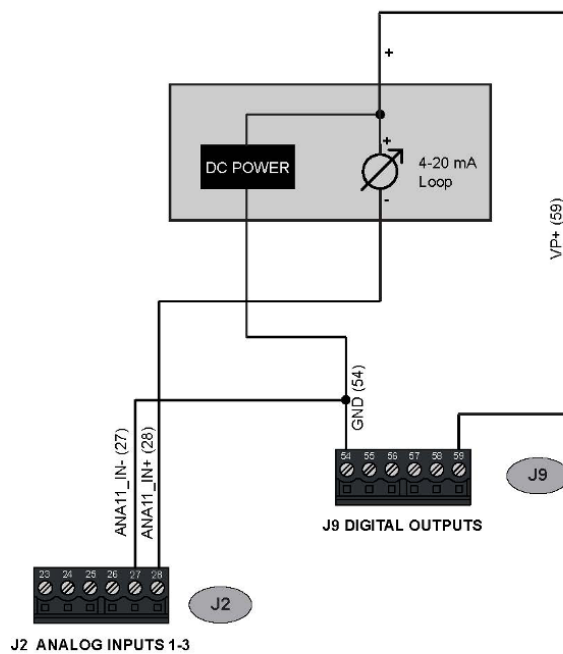

Refer to the sensor manufacturer's installation manual for specific connection details.

SENSEiQ™ Analog Input – 4-wire sensor

The diagram below shows how to connect a 4-wire sensor to a 4-20 mA analog input channel, using the voltage available from the register power bus.

Use the Digital Output terminal block to obtain DC power for the sensor. Voltage on the +VP terminal will be the same as the register power supply voltage.

For specific connection details, refer to installation manual from the sensor manufacturer.

Use a 12V power supply

Do not connect a sensor rated for +12V to a register operating from a +24 V power supply. Use a separate +12V DC power supply to properly operate the sensor.

ANALOG INPUT (4-20 mA) 4-WIRE SENSOR

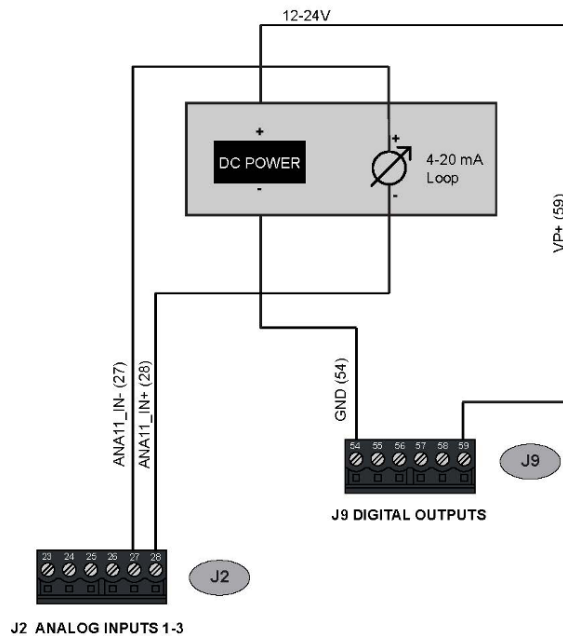

Refer to the sensor manufacturer's installation manual for specific connection details.

Wiring Diagram

Download a full-size, high-resolution PDF of the wiring diagram .

Remote Controls - Start, Stop & Print

Before setting up this feature, first install the hardware by connecting one or more momentary contact switches to the digital input(s)—either on the I/O board or the SENSEiQ board. Both boards use connector J11 for the digital inputs.

To verify that the push button has been connected successfully, go to the Diagnostics screens. While the button is pressed, the box corresponding to that digital input should be yellow in color.

To configure the software to use this feature, go to the I/O Setup screens and find the corresponding Digital Input. Use the **Up** and **Down** arrows to highlight that input, and then press **Enter** . Multiple inputs may be used for the same purpose, if desired.

Options:

- Remote End/Print – This ends the delivery (if a delivery is active). Otherwise, prints a duplicate ticket of the previous delivery.

Remote Start – Checks the start conditions and then begins a delivery

- **Remote Stop** – Pauses the delivery (if a delivery is active).

Valves

When ordered as part of a meter system with a Register, Liquid Controls control valves are bolted onto the meter and wired to the Register at the factory. Electronic control valves can also be ordered separately and retrofitted onto meter systems already in service. These valves will need to be piped and wired in the field. For piping instructions, refer to the valve manual. This manual includes wiring instructions for the valves.

Liquid Controls offers single-stage and two-stage electronic valves. Single stage valves have one solenoid valve (S1) and two positions—an open position and a closed position. Two-stage valves have two solenoid valves (S1 & S2) and three positions—open, closed, and dwell flow. Dwell flow is a low flow rate setting controlled by the S2 solenoid and initiated shortly before the register reaches a preset value.

Compatibility

The Register is also compatible with many other brands and types of valves.

This chapter covers:

- Single-Stage Valves
- Two-Stage Valves
- Valve Installation

Optical Air and Vapor Eliminators

Optical Air and Vapor Eliminator Installations

When ordered as part of a meter system with a Register, the Liquid Control optical air and vapor eliminators are bolted onto the strainer and wired to the Register at the factory. Optical air and vapor eliminators can also be ordered separately and installed onto meter systems already in service. For mechanical installation instructions, refer to the manual specific to the optical air and vapor eliminator. Instructions for wiring optical air and vapor eliminators to the Register are provided below.

Optical Air Eliminator (Refined Fuels)



Optical Vapor Eliminator (LPG and NH 3)



Materials needed for wiring valves

These materials are necessary, but are not supplied with the valve:

- 20 AWG stranded wire—3 per solenoid. Unnecessary for 3-way solenoid valves. Only 2 are necessary for E7 solenoids.
- Weatherproof flexible conduit, ½" diameter.
- ½" NPT conduit connectors or cable glands.
- PTFE tape or pipe sealant.

M7 meter system with optical air eliminator



Wire optical air and vapor eliminators to the Register

Refer to the figure below, and follow these steps:

1. Attach cable glands and/or conduit connectors to the S3 solenoid valve, the optical sensor, and the Register ports. Be sure to use thread sealant on NPT threads.
2. Thread the 20 AWG wires through a piece of weatherproof conduit cut-to-length from the S3 solenoid to a Register port
3. Run the weatherproof conduit between the S3 solenoid operated valve and the Register housing. Pull the wires through the ports, and tighten the connectors. Liquid Controls recommends running the optical sensor wire through weatherproof conduit as well.
4. Connect the two 20 AWG wires to the S3 solenoid operated valve terminals and to terminals 17 and 18 on the J2 terminal block of the Register board.
5. Connect the optical sensor wires to terminals 10, 11, and 12 on the J2 terminal block of the Register board.

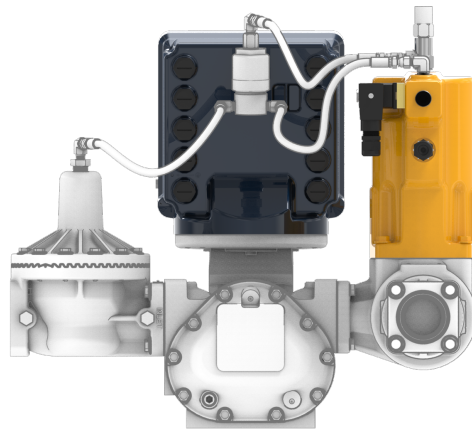

Disconnect Power

Disconnect the power before working on the CPU board.

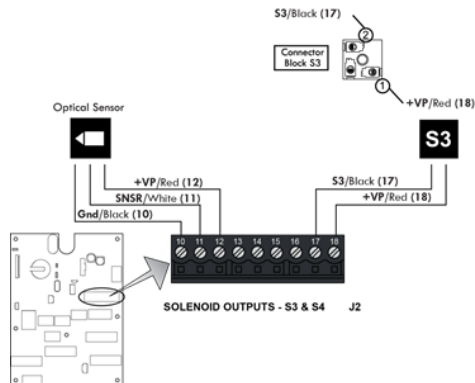

New Installations - Air Eliminators

When ordered with a new meter, the optical air eliminator is mounted atop a strainer on the inlet side of the meter. An example is the meter with high-capacity strainer, two-stage valve, and Lectro-Count LCR-II® Electronic Register shown in the Figure 6.

A vent line must be connected from the output port of the optical air eliminator. This connection is ½” NPT. The vent line must be connected to an appropriate receptacle, such as an overflow tank on a truck.

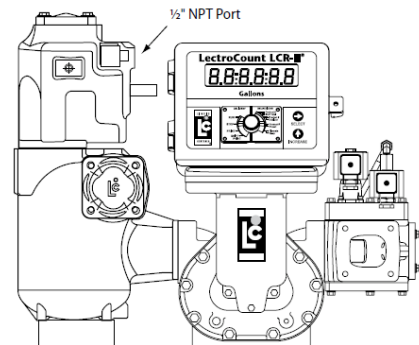

Figure 6: New Assembly

The optical air eliminator solenoid valve and optical sensor are supplied pre-wired to the Lectro-Count Electronic Register.

Retrofit Installations

Depending on the existing configuration, adding an optical air eliminator valve may require modification of the vent piping, modification or change of the outlet valve, and/or modification or change of the register.

The optical air eliminator requires the following components to operate:

- Lectro-Count LCR/LCR-II Electronic Register, with internal CPU board Part Number 81920 or LC³ with CPU board Part Number 81924.
- Electronically-controlled outlet valve such as the A2982-11 or A2848-11.

Refer to the manuals accompanying these items for proper installation and configuration. Read the warning below, and then continue on to the instructions for retrofitting an old air eliminator.



RELIEVING INTERNAL PRESSURE

All internal pressure must be relieved to zero pressure before disassembly or inspection of the strainer, vapor eliminator, any valves in the system, the packing gland, and the front or rear covers.

Serious injury or death from fire or explosion could result in performing maintenance on an improperly depressurized and evacuated system.

Strictly follow this procedure Relieving Internal Pressure Procedure for LPG and NH3 Meters:

1. Close the belly valve of the supply tank.
2. Close the valve on the vapor return line.
3. Close the manual valve in the supply line on the inlet side of the meter. If no manual valve exists on the inlet side, consult the truck manufacturer for procedures to depressurize the system.
4. Slowly open the valve/nozzle at the end of the supply line.
5. After product has bled off, close the valve/nozzle at the end of the supply line.
6. Slowly crack the fitting on top of the differential valve to relieve product pressure in the system. Product will drain from the meter system.
7. As product is bleeding from the differential valve, slowly reopen and close the valve/nozzle on the discharge line. Repeat this step until the product stops draining from the differential valve and discharge line valve/nozzle.
8. Leave the discharge line valve/nozzle open while working on the system.

These retrofit instructions will indicate a system using a Hi-Cap strainer/air eliminator. However, the optical air eliminator may also be installed on other LC strainer assemblies used for refined petroleum products.

Step 1 - Remove Old Air Eliminator and Baffle

Cup

After the internal pressure has been relieved from the system and the assembly drained of liquid, remove the four bolts and washers used to fasten the old air eliminator to the top of the strainer. Inspect the O-ring and replace if necessary.

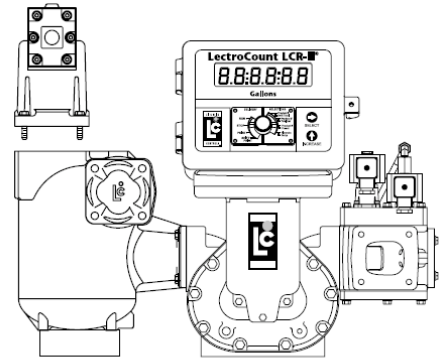

Figure 7: Remove Old Eliminator

Step 2 - Mount the Optical Air Eliminator

Depending on the strainer being used, the optical air eliminator may be fastened to the strainer/air eliminator in any of four 90° rotational increments. Select the most suitable orientation for ease of final installation of wiring and vent piping.

Fasten the optical air eliminator to the strainer using the four bolts and washers. Tighten the bolts to a torque of 27 lbf-ft (37 Nm).

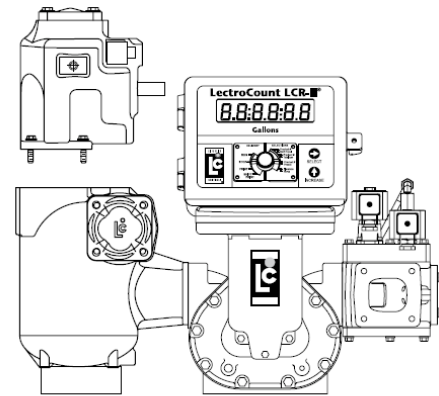

Figure 8: Orient the Optical Eliminator

Step 3 - Connect the Vent Piping/Tubing

This connection is 1/2" NPT. Remove the pipe thread protector and then connect the piping/tubing to the vent port. This piping typically connects directly to an overflow tank on a truck.

Step 4 - Wire the Solenoid and Sensor to the Register

The wiring instructions are given in below.

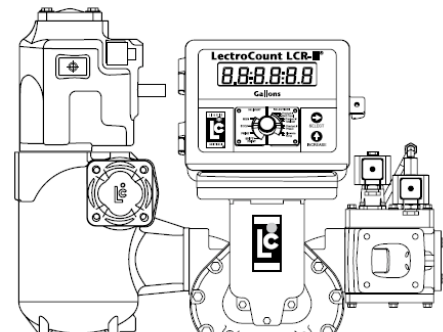

Figure 9: Fasten the Optical Eliminator

Wiring



WARNING

Incorrect wiring can damage the optical sensor.

For North American Installations, the installation must be fully in accordance with the National Electrical Code (US) or the Canadian Electrical Code respectively to maintain the hazardous location ratings on the product. This may involve using rigid conduit for all connections.

The optical air eliminator requires a Lectro-Count LCR/ LCR-II Electronic Register with CPU board part number 81920 (LC³ with 81924). If the LectroCount does not contain an 81920 CPU board (LC³ with 81924), this board must be ordered as a replacement to the existing CPU board.

The 81920 CPU board has an additional connector, connector J15, not present on other board models. On the LC³ 81924 CPU board, it is connector J11.

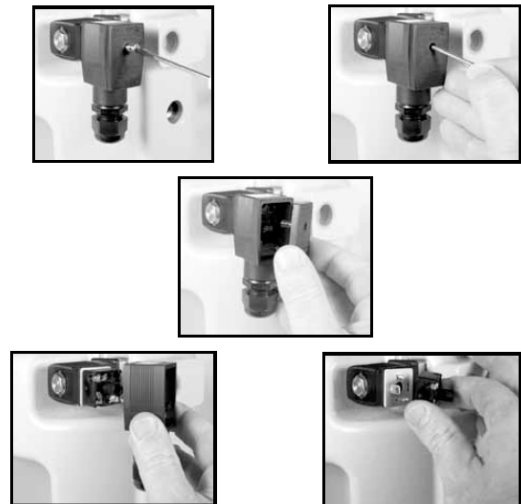

To make the connection to a Lectro-Count Register, the optical sensor comes supplied with a 24-inch cable. The cable is potted in the optical sensor assembly at one end. A threaded cord grip is included to fasten the other end of the cable into the back of the Lectro-Count Register. The solenoid requires a 12 AWG, two-wire, braided cable, approximately 24 to 36" in length.

Step 1 - Remove Cable Plug

Loosen and remove the screw from the cover of the S3 solenoid valve cable plug. Remove the cable plug from the solenoid valve coil. Remove the cover from the cable plug housing and then remove the terminal block. Be sure to note its orientation in the housing. Leave the flat gasket in place on the coil.

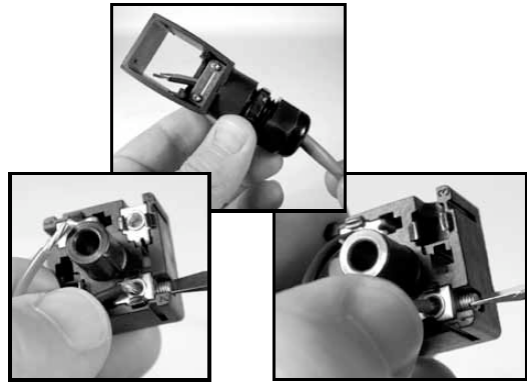

Step 2 - Connect Cable to Cable Plug

Route one end of the cable through the conduit fitting and into the cable plug housing. Connect the cable wires to the terminal block. Connect the BLACK wire to Terminal 2 and the RED wire to Terminal 1. These indicators are marked on the terminal block.

Step 3 - Reassemble Cable Plug

Reinstall the terminal block into the cable plug housing in the same orientation you found it. Tighten the strain relief strap inside the cable plug using the two screws. Tighten the cable gland on the bottom of the cable plug so that it seals around the cable.

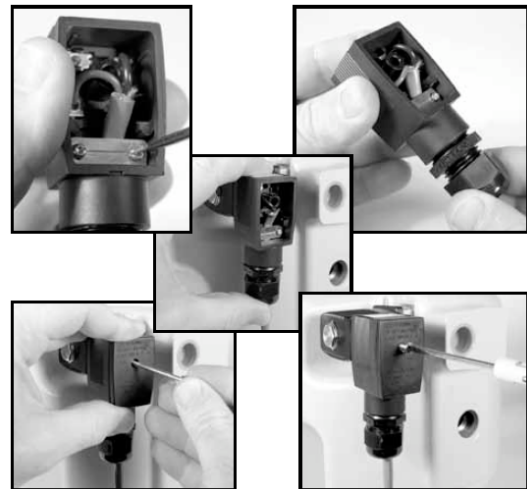

Reconnect the cable plug to the coil. Place the cover over the cable plug and fasten with the screw to a torque of 8.8 in-lbs (1 Nm).

Step 4 - Connect to Lectro-Count

Electronic Register

Route the cables from the optical sensor and solenoid valve to the back of the Lectro-Count register. Connect these to two open ports on the back of the register using the appropriate connectors.

LCR-II Connections

Connect the wires to terminal block J15 on the Lectro-Count CPU board. Refer to Figure 11a for additional clarification.

Optical Sensor Connection	
Wire Color	J15 Pin Connection
Red	56
White	55
Black	54

S3 Solenoid Connection	
Terminal	J15 Pin Connection
1 (Red)	52
2 (Black)	53

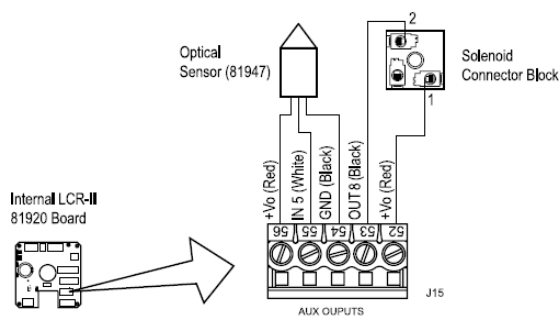

Figure 11: LCR-II to Optical Air Eliminator Wiring

LC 3 Connections

Connect the wires to terminal block J11 on the Lectro-Count CPU board. Refer to Figure 11b for additional clarification.

Optical Sensor Connection	
Wire Color	J11 Pin Connection
Red	33
White	34
Black	35

S3 Solenoid Connection	
Terminal	J11 Pin Connection
1 (Red)	31
2 (Black)	32

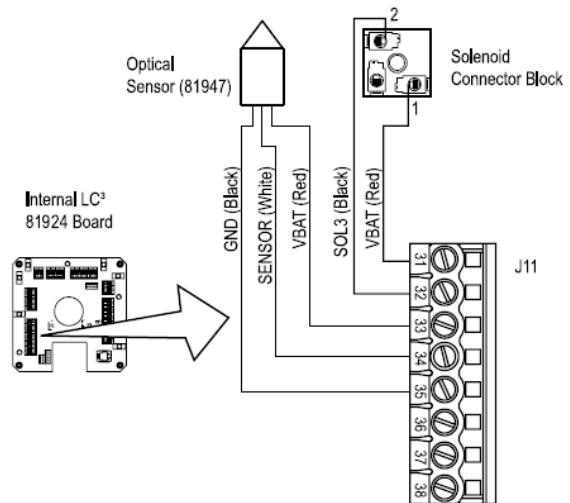

Figure 12: LC³ to Optical Air Eliminator Wiring

New Installations - Vapor Eliminators

When ordered with a new meter, the optical vapor eliminator is mounted atop a strainer on the inlet side of the meter. An example is the meter with high-capacity strainer, two-stage valve, and Lectro-Count LCR-II® Electronic Register shown in the Figure 6.

A vent line must be connected from the output port of the optical vapor eliminator. This connection is ½” NPT. The vent line must be connected to an appropriate receptacle on a supply or storage tank.

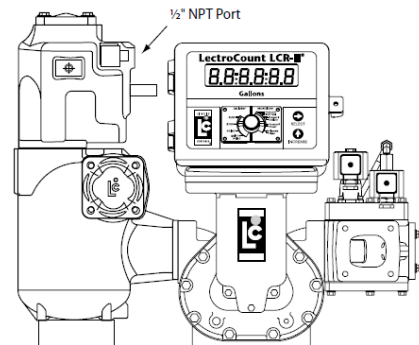

Figure 6: New Assembly

The optical vapor eliminator solenoid valve and optical sensor are supplied pre-wired to the Lectro-Count Electronic Register.

Retrofit Installations

Depending on the existing configuration, adding an optical vapor eliminator valve may require modification of the vent piping, modification or change of the outlet valve, and/or modification or change of the register.

The optical vapor eliminator requires the following components to operate:

- Lectro-Count LCR/LCR-II Electronic Register, with internal CPU board Part Number 81920 or 84040m or LC³ with CPU board Part Number 81924, or LCR 600 with CPU board 84040.
- Electronically-controlled outlet valve.

Refer to the manuals accompanying these items for proper installation and configuration. Read the warning below, and then continue on to the instructions for retrofitting an old vapor eliminator.



RELIEVING INTERNAL PRESSURE

All internal pressure must be relieved to zero pressure before disassembly or inspection of the strainer, vapor eliminator, any valves in the system, the packing gland, and the front or rear covers.

Serious injury or death from fire or explosion could result in performing maintenance on an improperly depressurized and evacuated system.

Strictly follow this procedure Relieving Internal Pressure Procedure for LPG and NH3 Meters:

1. Close the belly valve of the supply tank.
2. Close the valve on the vapor return line.
3. Close the manual valve in the supply line on the inlet side of the meter. If no manual valve exists on the inlet side, consult the truck manufacturer for procedures to depressurize the system.
4. Slowly open the valve/nozzle at the end of the supply line.
5. After product has bled off, close the valve/nozzle at the end of the supply line.
6. Slowly crack the fitting on top of the differential valve to relieve product pressure in the system. Product will drain from the meter system.
7. As product is bleeding from the differential valve, slowly reopen and close the valve/nozzle on the discharge line. Repeat this step until the product stops draining from the differential valve and discharge line valve/nozzle.
8. Leave the discharge line valve/nozzle open while working on the system.

To retrofit an optical vapor eliminator:

Step 1 - Remove Old Vapor Eliminator and Baffle Cup

After the internal pressure has been relieved from the system and the assembly drained of liquid, remove the four bolts and washers used to fasten the old vapor eliminator to the top of the strainer. Inspect the O-ring and replace if necessary.

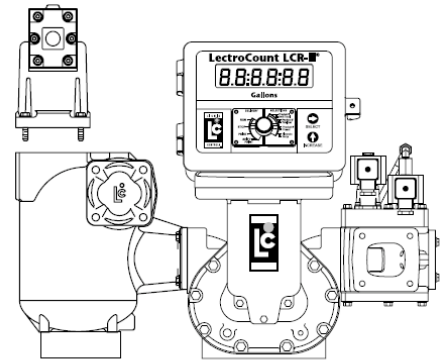

Figure 7: Remove Old Eliminator

Step 2 - Mount the Optical Vapor Eliminator

Depending on the strainer being used, the optical vapor eliminator may be fastened to the strainer/vapor eliminator in any of four 90° rotational increments. Select the most suitable orientation for ease of final installation of wiring and vent piping.

Fasten the optical vapor eliminator to the strainer using the four bolts and washers. Tighten the bolts to a torque of 27 lbf-ft (37 Nm).

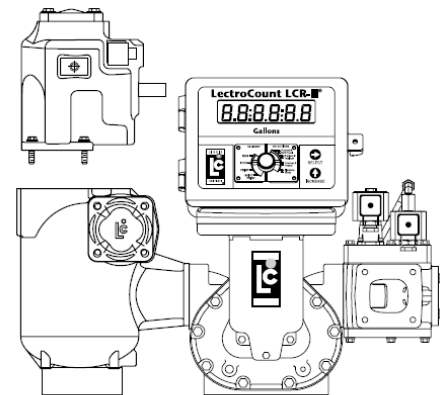

Figure 8: Orient the Optical Eliminator

Step 3 - Connect the Control Piping/Tubing for LPG

Make plumbing connections from the 3-way solenoid valve assembly to vapor eliminator and differential valve assembly. Follow the lettered designations in Figure 10.

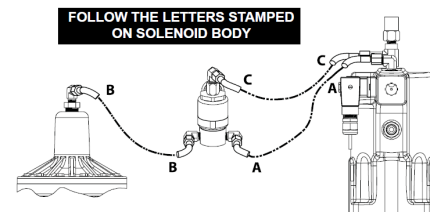

Figure 10: LPG Plumbing Connections

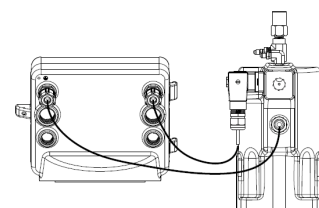

Figure 11: Optical Sensor and Solenoid Valve

Step 4 - Wire the Solenoid and Sensor to the Register

The wiring instructions are given in below.

Wiring



WARNING

Incorrect wiring can damage the optical sensor.

For North American Installations, the installation must be fully in accordance with the National Electrical Code (US) or the Canadian Electrical Code respectively to maintain the hazardous location ratings on the product. This may involve using rigid conduit for all connections.

The electrical installation of the optical vapor eliminator includes connecting the S3 solenoid and the optical sensor to the LectroCount register.

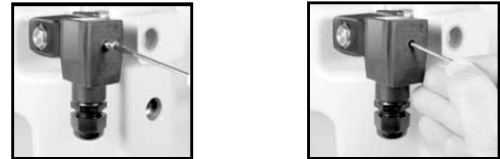

The optical sensor has a 24" cable potted to the inside the optical sensor assembly at one end. The other end of the cable has a threaded cord grip that fastens into the back of the LectroCount® register.



The S3 solenoid-operated valve requires a 12 AWG, two-wire, braided cable, approximately 24 to 36" in length.



The S3 solenoid-operated valve requires a LectroCount® LCR/LCR-II electronic register with CPU board part number 81920 or 84040 (LC³ with 81924). If the LectroCount® does not contain a proper CPU board (LC³ with 81924), replacement CPU boards can be ordered.

Both the 81920 and 84040 CPU board have an additional terminal, J15 (J11 on the LC³ 81924 CPU board). The extra terminal vital for operating the optical vapor eliminator, and it is not present on other board models.

Follow these steps to wire the S3 solenoid and the optical sensor:

Step 1 - Remove Cable Plug

Loosen and remove the screw from the cover of the S3 solenoid valve cable plug. Remove the cable plug from the solenoid valve coil. Remove the cover from the cable plug housing and then remove the terminal block. Be sure to note its orientation in the housing. Leave the flat gasket in place on the coil.

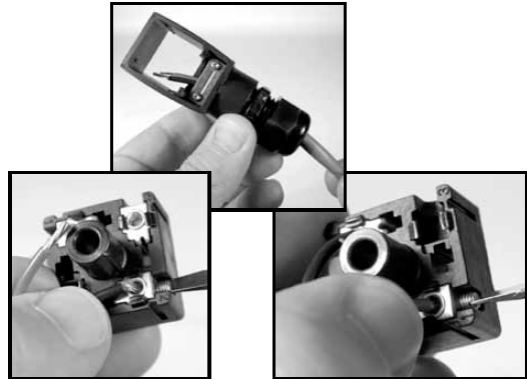

Step 2 - Connect Cable to Cable Plug

Route one end of the cable through the conduit fitting and into the cable plug housing. Connect the cable wires to the terminal block. Connect the BLACK wire to Terminal 2 and the RED wire to Terminal 1. These indicators are marked on the terminal block.

Step 3 - Reassemble Cable Plug

Reinstall the terminal block into the cable plug housing in the same orientation you found it. Tighten the strain relief strap inside the cable plug using the two screws. Tighten the cable gland on the bottom of the cable plug so that it seals around the cable.

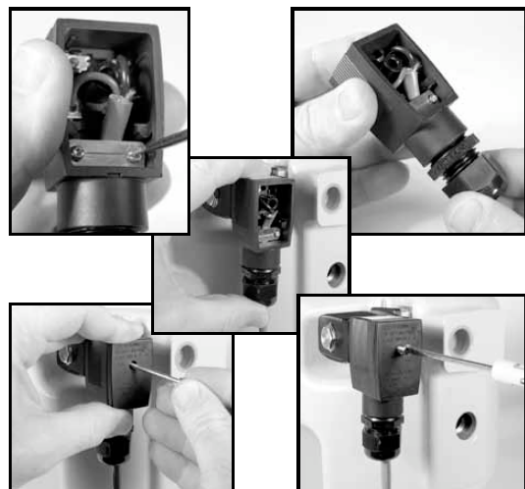

Reconnect the cable plug to the coil. Place the cover over the cable plug and fasten with the screw to a torque of 8.8 in-lbs (1 Nm).

Step 4 - Connect to Lectro-Count Electronic Register

Route the cables from the optical sensor and solenoid valve to the back of the Lectro-Count register. Connect these to two open ports on the back of the register using the appropriate connectors.

LC 3 Wiring

Optical Sensor Connection

Wire Color	J11 Pin Connection
Red	33
White	34
Black	35

S3 Solenoid Connection

Terminal	J11 Pin Connection
1 (Red)	31
2 (Black)	32

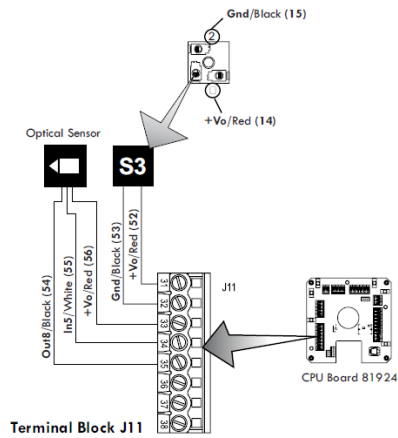

LCR Wiring

Optical Sensor Connection

Wire Color	J15 Pin Connection
Red	56
White	55
Black	54

S3 Solenoid Connection

Terminal	J15 Pin Connection
1 (Red)	52
2 (Black)	53

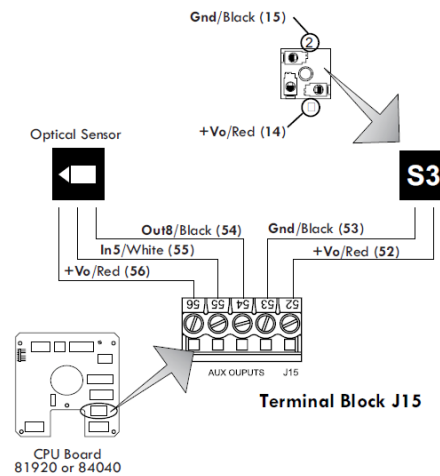

Pulse Output Device

Pulse Output Device (POD) Installation

When ordered as part of a meter system with a Register, the Liquid Controls Pulse Output Device (POD) is typically installed onto the meter and wired to the Register at the factory. The POD can also be ordered separately and installed onto meter systems already in service. For mechanical installation instructions, refer to the POD manual. Instructions for wiring the POD to the Register are given below.



Disconnect Power

Disconnect the power before working on the CPU board.

These materials are necessary, but are not supplied with the POD:

- 16-22 AWG 4 conductor Shielded Cable (Consult the POD manual for complete specifications)
- Weather Proof flexible conduit or loom
- ½” Conduit connectors or cable glands
- PTFE tape or thread sealant

Single Channel Pulse Inputs

The Register is compatible with the many single channel pulse output devices.

To wire a single channel pulse output to the Register:

1. Go to Main Menu / Setup Menu / Meter Settings. Select Pulse Input Type, Single Channel.
2. Connect the three pulser terminals (V out, Channel A, and ground) as follows:

- Pulser channel A to Register terminal 69

- Pulser voltage out to Register terminal 70
- Pulser ground to Register terminal 63

New Installations



When ordered with the flowmeter, the POD comes factory installed on the meter and ready for wiring. Wiring instructions begins on page 10.



RELIEVING INTERNAL PRESSURE

All internal pressure must be relieved to zero pressure before disassembly or inspection of the strainer, vapor eliminator, any valves in the system, the packing gland, and the front or rear covers.

Serious injury or death from fire or explosion could result in performing maintenance on an improperly depressurized and evacuated system.

Strictly follow this procedure Relieving Internal Pressure Procedure for LPG and NH3 Meters:

1. Close the belly valve of the supply tank.
2. Close the valve on the vapor return line.
3. Close the manual valve in the supply line on the inlet side of the meter. If no manual valve exists on the inlet side, consult the truck manufacturer for procedures to depressurize the system.
4. Slowly open the valve/nozzle at the end of the supply line.
5. After product has bled off, close the valve/nozzle at the end of the supply line.
6. Slowly crack the fitting on top of the differential valve to relieve product pressure in the system. Product will drain from the meter system.
7. As product is bleeding from the differential valve, slowly reopen and close the valve/nozzle on the discharge line. Repeat this step until the product stops draining from the differential valve and discharge line valve/nozzle.
8. Leave the discharge line valve/nozzle open while working on the system.

Retrofit Installations

Follow these procedures to remove the existing hardware:

1. Relieve the pressure from the process piping to the meter.
2. Drain the meter by opening the meter's drain plugs.

NOTE 1: Meters with only two packing gland

mounting screws are limited to four orientations.

NOTE 2: When using a cable gland to seal the wire entrance, any of the eight orientations can be used. However, when using conduit, the hub should face down so moisture that may accumulate in the conduit will drain away from the POD electronics.



Remove Packing Gland Mounting Screws

3. Remove the mechanical counter, adjuster, and adjuster drive shaft from the front of the meter.
4. Some meters have a counter adapter bracket which is bolted on. If this is the case, remove the counter bracket by removing the bolts that hold it in place. If the counter adapter bracket is integral to the meter, it cannot be removed. In this case, one of four POD Pulser Extensions will be required.



Packing Gland Removed

1. Remove the packing gland mounting screws. Pull the packing gland out of the meter. If the O-Ring does not come out with the packing gland, be sure to remove it from the packing gland well before installing the POD.

Installing the POD

POD Extension Kits

If a POD Extension Kit is necessary, it must be installed prior to installation of the POD. See POD Extension Kit Installation.

Follow these steps to install the POD onto a flowmeter:

1. Verify that the proper POD Model was obtained by comparing the driver tang on the POD to the driver tang on the packing gland that was removed in Step 5 of the **Retrofit Installations** section above. There are two types of packing

gland/POD driver tangs: blade type and fork type. Blade type packing glands must be replaced with blade type PODs. Fork type packing glands must be replaced with fork type PODs.



Blade Style Tang (Left) and Fork Style Tang (Right)

2. Determine the desired orientation of the conduit hub. The hub can be positioned in one of eight possible orientations as shown in the figure to the right.

3. Position the O-Ring over the bottom of the POD as shown to the right.

4. Align the fork style or blade style driver with the drive mechanism in the meter and guide the POD into the opening in the meter cover. When properly aligned, the POD will go in until its mounting flange abuts the meter cover.

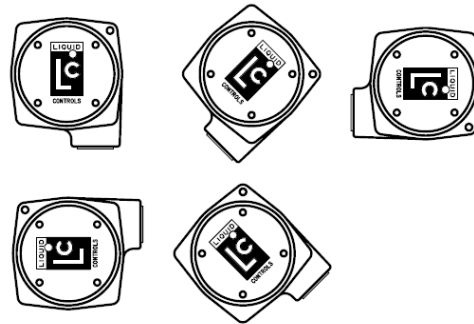

Recommended POD Conduit Hub Orientations

5. Rotate the POD to the desired orientation and thread in the mounting screws until they are snug. Using a 7/32" box end wrench, tighten the screws and torque them to 21-25 inch-pounds.

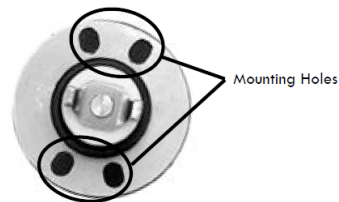
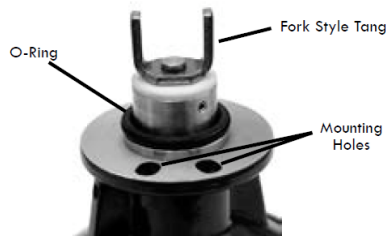

Wiring the Pulse Output Device to a register

Follow these steps:

1. Go to Main Menu / Setup Menu / Meter Settings. Make sure Pulser Input Type is set to Dual Channel.
2. Attach cable glands and/or conduit connectors to the POD and the Register port(s). Make sure to use thread sealant on NPT threads.
3. Thread the wires through a piece of weatherproof conduit cut-to-length from the POD port to a Register port.
4. Run the weatherproof conduit between the POD and the Register housing, pull the wires through the ports, and tighten the connectors.
5. Connect the four POD terminals to four terminals on the J11 terminal block of the Register CPU board.
 - POD terminal 20 to Register terminal 70
 - POD terminal 21 to Register terminal 68
 - POD terminal 22 to Register terminal 69
 - POD terminal 23 to Register terminal 63

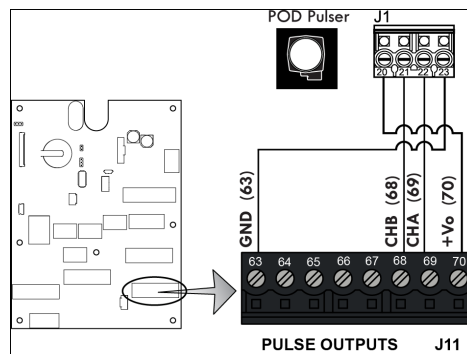

Differential Pressure Transducer

Differential Pressure (Δ P) Transducer Installation

When ordered as part of a meter system with a Register, the Liquid Control Δ P transducer is wired to the Register at the factory. The Δ P transducer can also be ordered separately and installed onto a meter system already in service. Refer to the Δ P transducer manual for complete installation instructions. Instructions for wiring the Δ P transducer to the Register can be found below.

Typically, a Δ P transducer operates together with a shutdown device, such as a valve or a dead-man.

Follow these steps to wire Δ P Transducer to the Register:

1. Route the Δ P transducer cable through a cable gland in a port on the back of the Register. Secure the cable gland. *LC recommends running the cable through weatherproof conduit* . Make sure to use thread sealant on NPT threads.
2. Connect the four Δ P transducer wires to terminals to the recommended Register terminals as follows:
 - + VP / Black to terminal 12
 - GND / White (Ground) to 36
 - B / Yellow to terminal 38
 - A / Blue to terminal 37

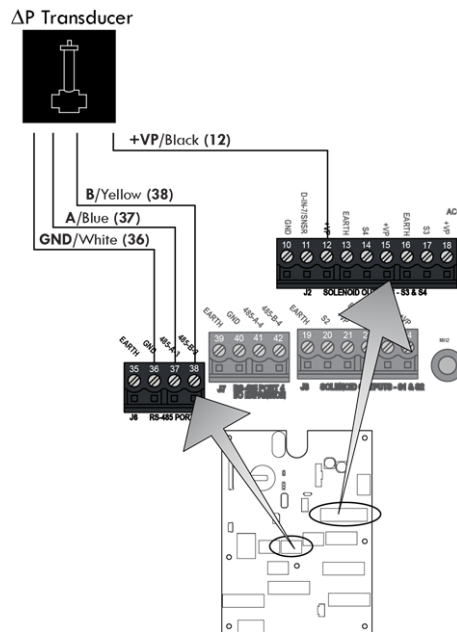

3. Route a two-wire cable from the shutdown control device through a cable gland in a port on the back of the Register. Secure the cable gland. Make sure to use thread sealant on NPT threads. Liquid Controls recommends running the cable through weatherproof conduit.
4. Connect the two wires from the shutdown control device to terminals 23 (S1) and 24 (+VP).

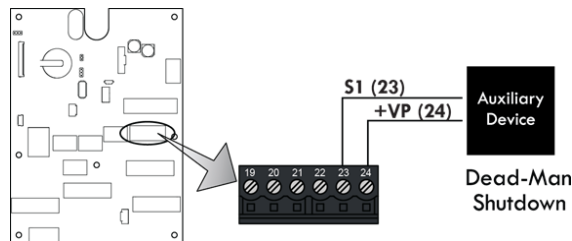

Current Draw on Shutdown Device

The shutdown device should draw no more than 1 Amp.

External Antenna Kit

The External Antenna Kit extends the operational range of the wireless features of the E6000- series LCRiQ Electronic Register. The kit contains a 2.4 GHz antenna, suitable for outdoor installation, mounting bracket, and coaxial cable with mating connectors.

Parts List

The external antenna kit contains these parts:

84373 – Antenna, 2.4 GHz, Mobile, N-female connector · 84374 – Antenna Mount, Mobile, trunk groove/fender bracket, 5/8” hole · 84375 – Coaxial Cable, RG-58, N-male to SMA-male connectors · 71560 – Cord Grip, ½” NP



Installation

Break the calibration seal

This procedure requires breaking the calibration seal and opening the register.

Placement of the antenna

Placement affects performance

Proper antenna placement is critical for successful wireless operation.

Step 1 – Decide on a mounting location for the antenna, which must be within 10 feet of the register.

Wireless performance can vary from vehicle to vehicle, depending on antenna height and placement. Follow these guidelines to achieve the best performance:

- The remote device must be able to receive the antenna signal — wi-fi signals follow line-of sight.

Install the antenna as high as possible. · Attach the mounting bracket to the metal structure of the truck, using suitable metal

hardware. This antenna uses the metal on the truck as a ground plane for proper operation.



- Avoid installing the antenna on one side of the truck, unless this is desired operation. The metal will block the signal from the opposite side.
- Do not attempt to extend the length of the antenna cable. Longer cable length will attenuate the radio signal, which severely reduces wireless performance.
- Do not install outboard power amplifiers between the antenna and register — this may violate applicable radio regulations and damage register components.

Avoid bending the antenna cable in a radius sharper than 3 inches. · Do not attempt to repair or splice damaged antenna cable. Replace damaged cable with

LC part 84375.

Replace damaged antenna with LC part 84373. · Use the included cable gland to protect LCRiQ from moisture entry when installing the

coaxial cable.

- If in-cab connectivity of wi-fi / Bluetooth is desired, mount the antenna as close as possible to the vehicle cab. Consider mounting the register closer to the cab and installing a POD pulser on the meter.



Step 2 – Attach the mounting bracket to the vehicle. Use metal fasteners and hardware to ensure good bonding to the metal of the vehicle. Orient the mounting bracket so the antenna is vertical. Install the antenna in a vertical orientation only. Mounting the antenna horizontally severely reduces wireless performance.

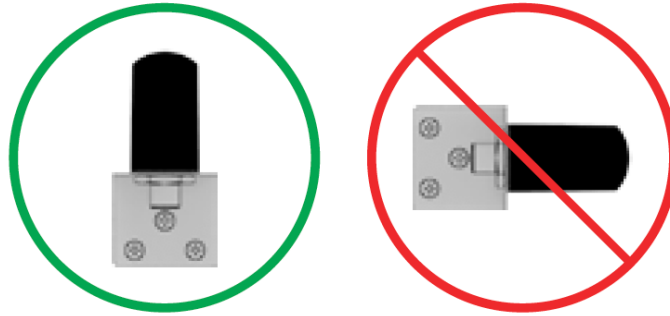

Step 3 – Begin to assemble the antenna to the mounting bracket by unscrewing the nut and removing the lockwasher.



Insert the antenna into the bracket and install the lockwasher, as shown.



Install the nut and tighten securely with a 1-inch wrench.



Step 4 – Connect the coaxial cable to the antenna with the N-connector.

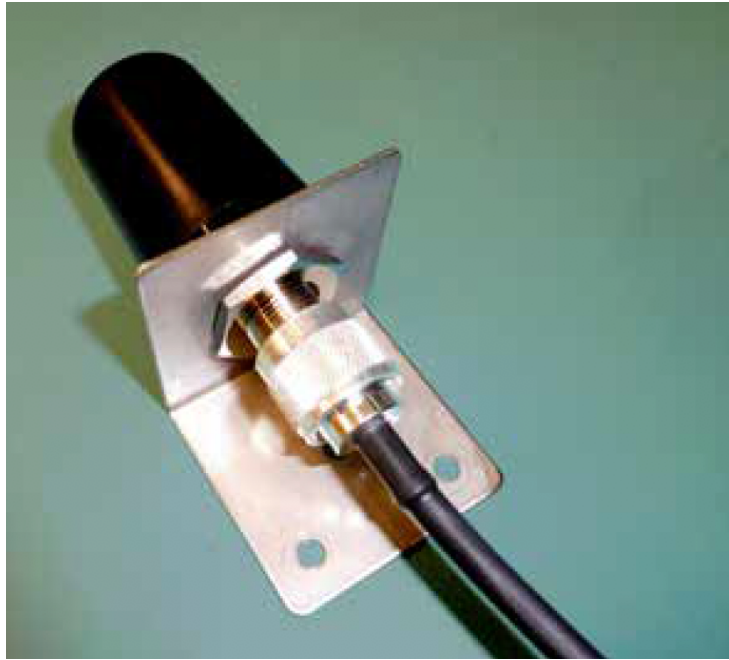

Step 5 – Insert the cable gland on the SMA end of the cable.

Step 6 – Install the cable gland on the register.

Step 7 – Unscrew the internal antenna and connect the coaxial cable to the SMA connector. Gently tighten the SMA connector with a 5/16-inch wrench.

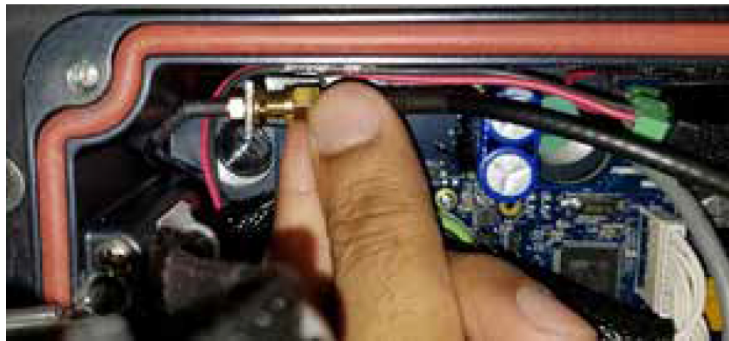

Step 7b – Alternate method for bottom-mounted SMA connector. Unscrew the internal antenna and connect the coaxial cable to the SMA connector. Gently tighten the SMA connector with a 5/16-inch wrench.

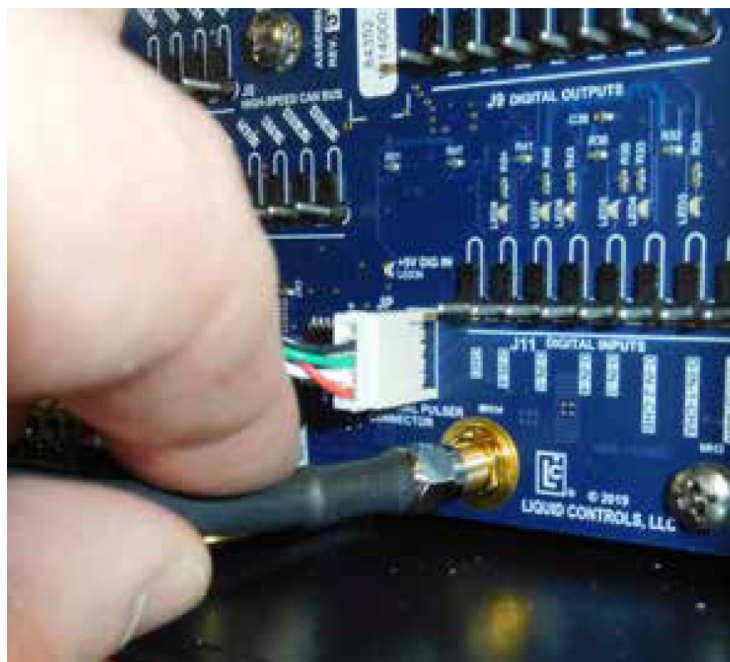
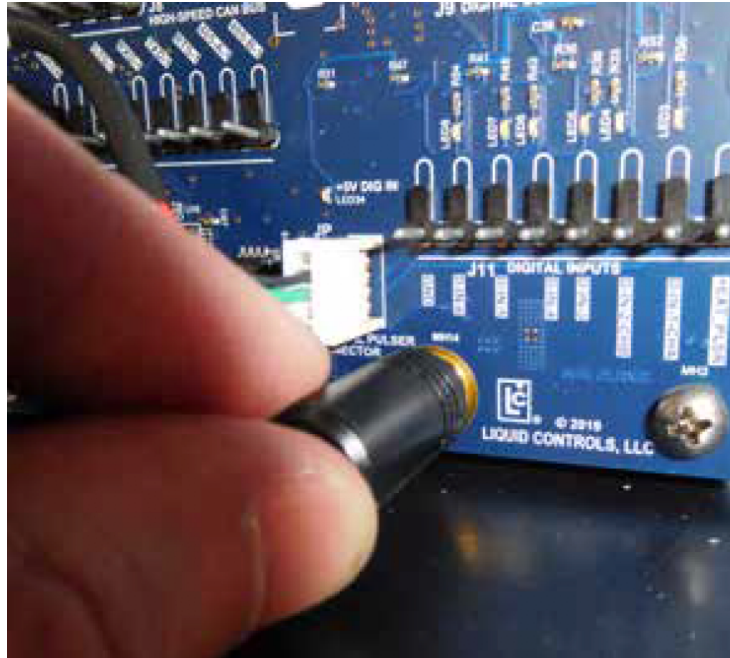

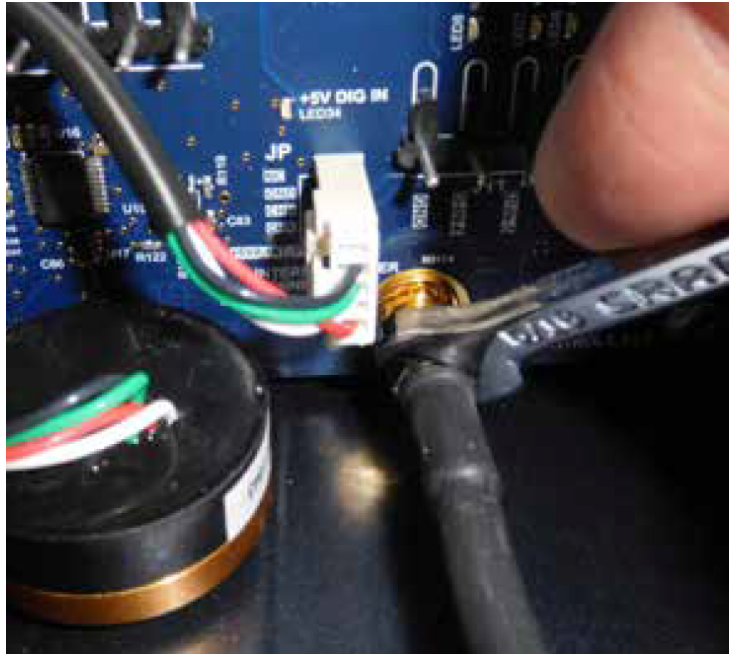

Step 8 – Close the register.

Step 9 – Tighten the cable gland until it securely anchors the antenna cable.

Step 10 – Make a small loop facing downward as the cable leaves the register. This allows water to drip down away from the register.



Step 11 – Attach the cable securely to the vehicle using wire ties or insulated wire clamps. The cable requires no special standoffs.

Step 12 – Close and seal the register.

Step 13 – Installation is complete. The register requires no changes to any settings.

Water Detectors

The MASTERLOADx.iQ registers are capable of integrating industry approved water detection devices to meet aviation JiG safety standards regarding water in fuel. This manual describes the setup and configuration process of integrating a water detector which relies on 4-20mA analog communication.

Compatibility
<p>Water Detectors are compatible with MASTERLOADx.iQ registers with I/O boards Revision J or greater.</p> <p>NOTE: To identify which board you have, examine the board types given in Interface Board Identification  110.</p>

Follow these steps below to install and configure a water detector.

Step 1 – Enter the Calibration mode for the Register by rotating the W&M screw counterclockwise.

Step 2 – Enable the Water Sensor service:

- a. Open the I/O Setup screen in the Setup Menu .
- b. Open the Services screen by pressing the Services hot key.
- c. Select the **Water Service** field by pressing Up or Down keys and then Press **Enter** .
- d. Select **Yes** and press the **OK** key.
- e. Return to the I/O Setup screen by pressing the Close hot key.

Step 3 – Setup the Water Service parameters for the Analog Port of the I/O board to which the water sensor is connected. The water sensor is using the 4-20 mA current loop for its operation. The register fields related to water sensor operation can be accessed from I/O Setup screen 3:

a. Open I/O Setup screen 3 by pressing the Right or Left arrow key. b. Select the **Analog Input ANA** field by pressing the Up or Down key. c. Press the **OK** key and enter the **Name** of the input. Press the **OK** key. d. Enter the Analog Input Setup screen by pressing the **Sensor Setup** hot key. e. Select the **Sensor Type** field, press the **OK** key, and select **Water Sensor** from the

pull-down list. Press the **OK** key.

f. Select the **Unit of Measure** field, and then select PPM as a unit of measure to be used for water level detection.

g. Activate the alarm actions when the analog input current is out of the required range. To activate the alarm, select either the **< 4mA** or **> 20mA** field and choose **Error** from the pull-down list. Press the **OK** key.

h. Set the water level associated with a 4mA input current. Select the 4mA is field, press the **OK** key, and set the value of the water level to 0. Press the **OK** key.

i. Set the water level associated with a 20mA input current. Select the 20mA is field, press the **OK** key, and set the value of the water level to 50. Press the **OK** key.

j. Set the time in seconds required for the water level to continuously be at the selected level before the alarm actions will be activated. Select the **Analog Error Delay** field, press the **OK** key, and enter the time in a range from 0 to 10 seconds. Press the **OK** key.

k. Choose what water levels detected during delivery will be printed on the delivery ticket.

The average, low, or high levels can be printed by selecting the **Yes** options for those fields. Typically, high is set to **Yes**, and average and low are set to **No**.

l. Set the parameters for the first trigger to be used to monitor the water level during delivery:

- Select the first trigger field and press **OK** key. - Select if an action has to occur when the water level is above or below the corresponding trigger level. - Select the **Above** option from the pull-down list and press the **OK** key. - Enter a trigger threshold of 15 and press the **OK** key. - Select the delivery action to be taken when the trigger occurs. Select the **Stop** option

from the pulldown list and press the **OK** key. - Select the Digital Output of the I/O board to be used with the trigger. Outputs from 1 to 6 can be used.

NOTE: Ensure that the selected output has not been used for different actions of the register. Use the pulldown list to select the desired output.

m. Set the parameters for the second trigger to be used to monitor the water level during delivery:

- Select the second trigger field and press **OK** key. - Select if an action has to occur when the water level is above or below the corresponding trigger level. - Select the **Above** option from the pulldown list and press the **OK** key. - Enter a trigger threshold of 30 and press the **OK** key. - Select the delivery action to be taken when the trigger occurs. Select the End option from the pulldown list and press the **OK** key. - Select the **Digital Output** of the I/O board to be used with the trigger. The output should be the same as the one selected for the first trigger.

n. If desired, select and configure another trigger. Up to 4 different triggers can be configured for the Analog Input of the I/O board.

o. Complete the Analog Input Setup by pressing the Close hot key.

Printers

Printer Installation (J1 RS-232)

A Liquid Controls meter system with a Register typically includes an Epson slip printer or roll printer. The installation is the same for either printer.

See instructions in Routing Data and Power Cables of the truck to the cab.

 for routing the data cable from the back

Disconnect Power

Disconnect the power before working on the CPU board.

To wire a Printer to the Register:

1. Go to Main Menu / Setup Menu / Register Settings (3/3) - Printer Type. Ensure proper printer is selected in the drop down selection field.
2. Attach cable glands and/or conduit connectors to the Register port. Make sure to use thread sealant on NPT threads.
3. Connect the wires to the J13 and J14 terminal blocks of the Register board.

GND / Black to terminal 80 ·
 CTS / Blue to terminal 81 ·
 RXD / Yellow to terminal 82
 · TXD / Orange to terminal
 83 · RTS / Brown to terminal
 84 · RTS / Red to terminal
 92 · TXD / Violet to terminal
 91 · RXD / Gray to terminal
 90 · CTS / Green to terminal
 89 · GND / White to terminal
 88

Routing Data Cables

See the instructions on Routing Data and Power Cables

 for routing the data cable from the back of the truck to the cab.

To install the printer:

1. Mount the printer in the truck cab where drivers can easily operate it. 2. Clean the mounting spot and the bottom of the printer with alcohol for the best adhesion. 3. Attach Velcro to the mounting area and the bottom of the printer. Fasten the printer to the mounting area.
4. Connect the data cable to the RS-232 data port on the back of the printer.

Connecting Power

To connect power to the printer, see Power Supply



Epson Printer Ground Wire Kit Installation

Before connecting power to the Register and the Epson printer, ground the printer to the truck cab floor. Epson printers sold for truck installations are all grounded in the same manner.

- 82184 - Epson Printer Ground Wire Kit			
#	Description	Part Number	Quantity
1	Ground Wire	84101	1
2	Terminal (.375 ring, 16GA)	71878	1

Follow these steps to ground an Epson printer:

1. Remove one of the mounting bolts that fasten the printer mounting brackets to the truck cab floor.
2. Place one end terminal of the ground wire over the mounting bolt and return the bolt to its original place.
3. At the back of the Epson printer, remove the silver ground screw marked “FG”. 4. Place the other end terminal of the ground wire over the ground screw and return the screw to its original place.
5. Check the strap for a good ground connection (see page 13).

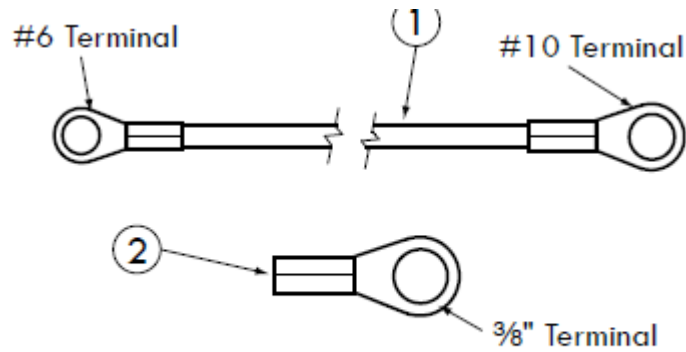

Epson Printer Ground Wire Kit

Additional Terminal

The Epson Printer Ground Wire Kit contains an additional 3/8" ring terminal for printer des colliers de serrage non achetés auprès de Liquid Controls.

Impression en ligne

Système à deux débitmètres avec impression en ligne (sans LCP en ligne utilisé)

Dual Meter System with Pass Through Printing (No Pass Through LCP used)											
Screen	Field	Register 1	Type	Baud	Timeout	Retries	Register 2	Type	Baud	Timeout	Retries
I/O Setup (1/4)	COM 0	Printer	RS232	9600			Not Used				
	COM 1	LCP					LCP				
	COM 2	LCR.iQ Network	RS485	115200	200	1	LCR.iQ Network	RS485	115200	200	1
	LCP Node Address	1					2				
		Register 1					Register 2				
I/O Setup Services	Master Slave Setting	Master					Slave				
>LCR.iQ Network	# of Slave Devices	1									
>Setup Network	Slave Device #	1									
	Slave Device Node	2									
	Ticket Printing	Yes					Yes				
	Pass Through LCP	No									

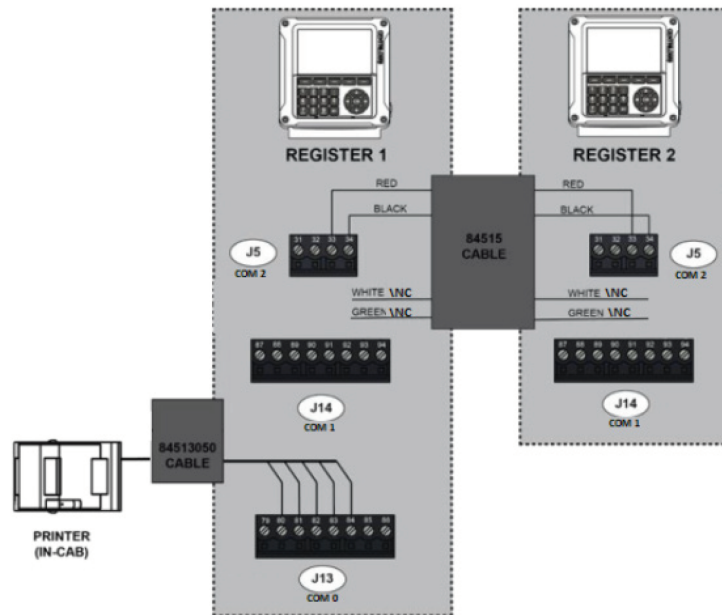

Système à trois (ou plus) débitmètres avec impression en ligne (sans passage Through LCP used)

Three (or more Dev.) Meter System with Pass Through Printing (No Pass Through LCP used)																	
Screen	Field	Register 1	Type	Baud	Timeout	Retries	Register 2	Type	Baud	Timeout	Retries	Register 2	Type	Baud	Timeout	Retries	
I/O Setup (1/4)	COM 0	Printer	RS232	9600			Not Used					Not Used					
	COM 1	LCP					LCP					LCP					
	COM 2	LCR.iQ Network	RS485	115200	200	1	LCR.iQ Network	RS485	115200	200	1	LCR.iQ Network	RS485	115200	200	1	
	LCP Node Address	1					2					3 (+1 per Dev.)					
I/O Setup Services	Master Slave Setting	Master					Slave					Slave					
	>LCR.iQ Network	# of Slave Devices	1			(+1 Per Dev.)											
	>Setup Network	Slave Device #	1			(+1 Per Dev.)											
		Slave Device Node	2			(+1 Per Dev.)											
		Ticket Printing	Yes				Yes					Yes					
		Pass Through LCP	No														

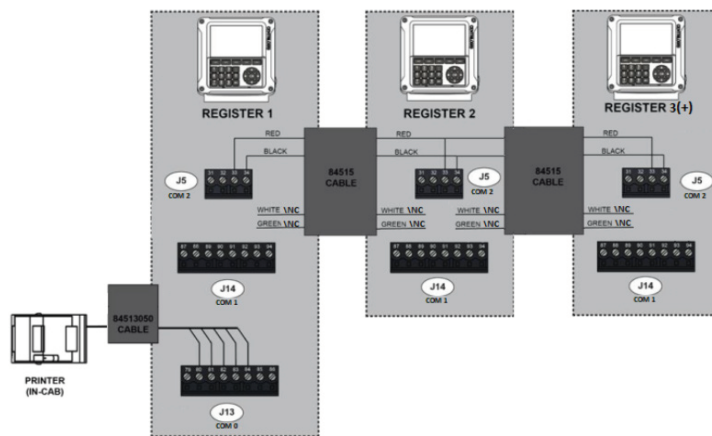

Dual Meter System with Pass Through Printing and Pass Through LCP Using RS485 Device

Dual Meter System with Pass Through Printing and Pass Through LCP Using RS485 Device											
Screen	Field	Register 1	Type	Baud	Timeout	Retries	Register 2	Type	Baud	Timeout	Retries
I/O Setup (1/4)	COM 0	Printer	RS232	9600			Not Used				
	COM 1	LCP	RS485	19200	500	1	LCP	RS485	19200	500	1
	COM 2	LCR.iQ Network	RS485	115200	200	1	LCR.iQ Network	RS485	115200	200	1
	LCP Node Address	1					2				
		Register 1					Register 2				
I/O Setup Services	Master Slave Setting	Master					Slave				
>LCR.iQ Network	# of Slave Devices	1									
>Setup Network	Slave Device #	1									
	Slave Device Node	2									
	Ticket Printing	Yes					Yes				
	Pass Through LCP	Yes									

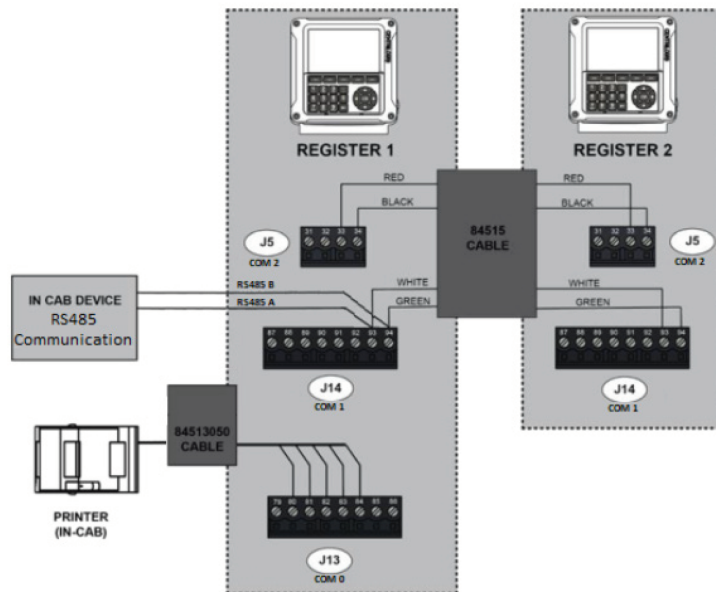

Three (or more Dev.) Meter System with Pass Through Printing and Pass Through LCP Using RS485 Device

Three (or more Dev.) Meter System with Pass Through Printing and Pass Through LCP Using RS485 Device																
Screen	Field	Register 1	Type	Baud	Timeout	Retries	Register 2	Type	Baud	Timeout	Retries	Register 2	Type	Baud	Timeout	Retries
I/O Setup (1/4)	COM 0	Printer	RS232	9600			Not Used					Not Used				
	COM 1	LCP	RS232	19200	500	1	LCP					LCP				
	COM 2	LCR.iQ Network	RS485	115200	200	1	LCR.iQ Network	RS485	115200	200	1	LCR.iQ Network	RS485	115200	200	1
	LCP Node Address	1					2					3 (+1 per Dev.)				
		Register 1				Register 2				Register 3						
I/O Setup Services	Master Slave Setting	Master					Slave					Slave				
>LCR.iQ Network	# of Slave Devices	1														
>Setup Network	Slave Device #	1	2													
	Slave Device Node	2	3													
	Ticket Printing	Yes					Yes					Yes				
	Pass Through LCP	Yes														

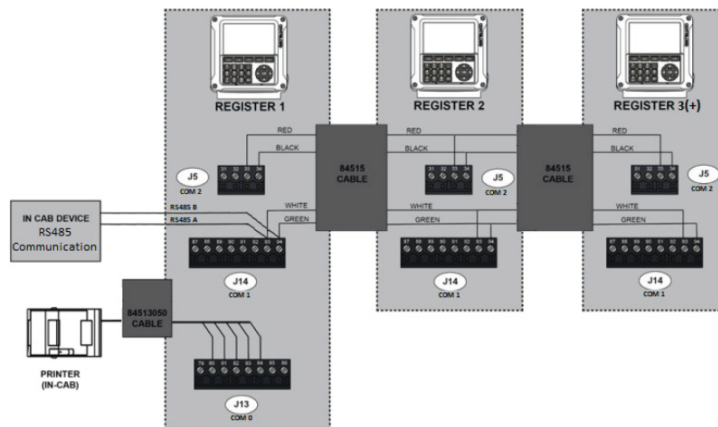

Dual Meter System with Pass Through Printing and Pass Through LCP Using RS232 Device

Dual Meter System with Pass Through Printing and Pass Through LCP Using RS232 Device											
Screen	Field	Register 1	Type	Baud	Timeout	Retries	Register 2	Type	Baud	Timeout	Retries
I/O Setup (1/4)	COM 0	Printer	RS232	9600			Not Used				
	COM 1	LCP	RS232	19200	500	1	LCP				
	COM 2	LCR.iQ Network	RS485	115200	200	1	LCR.iQ Network	RS485	115200	200	1
	COM 3	LCR.iQ Network	RS485	115200	200	1	LCR.iQ Network	RS485	115200	200	1
	LCP Node Address	1					2				
		Register 1				Register 2					
I/O Setup Services	Master Slave Setting	Master					Slave				
>LCR.iQ Network	# of Slave Devices	1									
>Setup Network	Slave Device #	1									
	Slave Device Node	2									
	Ticket Printing	Yes					Yes				
	Pass Through LCP	Yes									

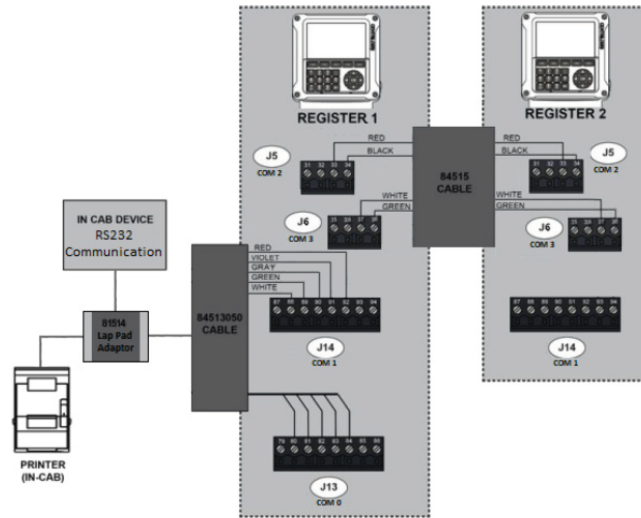

Three (or more Dev.) Meter System with Pass Through Printing and Pass Through LCP Using RS232 Device

Three (or more Dev.) Meter System with Pass Through Printing and Pass Through LCP Using RS232 Device																
Screen	Field	Register 1	Type	Baud	Timeout	Retries	Register 2	Type	Baud	Timeout	Retries	Register 3	Type	Baud	Timeout	Retries
I/O Setup (1/4)	COM 0	Printer	RS232	9600			Not Used					Not Used				
	COM 1	LCP	RS232	19200	500	1	LCP					LCP				
	COM 2	LCR.iQ Network	RS485	115200	200	1	LCR.iQ Network	RS485	115200	200	1	LCR.iQ Network	RS485	115200	200	1
	COM 3	LCR.iQ Network	RS485	115200	200	1	LCR.iQ Network	RS485	115200	200	1	LCR.iQ Network	RS485	115200	200	1
	LCP Node Address	1					2					3 (+1 per Dev.)				
		Register 1			Register 2			Register 3								
I/O Setup Services	Master Slave Setting	Master					Slave					Slave				
>LCR.iQ Network	# of Slave Devices	2														
>Setup Network	Slave Device #	1	2													
	Slave Device Node	2	3													
	Ticket Printing	Yes					Yes					Yes				
	Pass Through LCP	Yes														

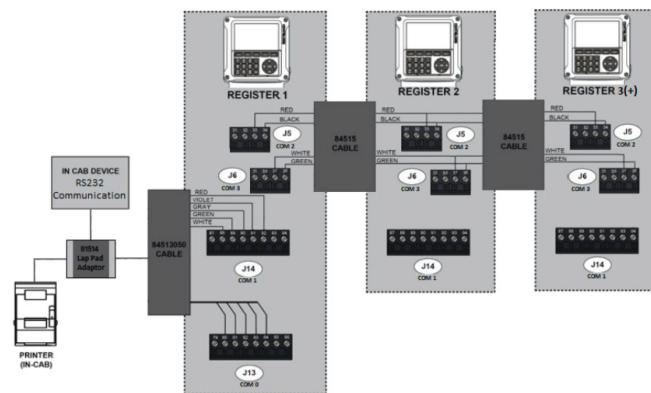

Large-Digit Remote Display

The LectroCount® Large-Digit Remote Display can be used with the MASTERLOADx.iQ registers to provide long range visibility of either Flow Rate or Delivery Volume Quantity. In calibration mode, the LC Remote Display will display the Measured Quantity when Quantity is selected for LC Remote Display Value.

The sections below explain how to make the electrical connections and then configure the remote display.

Electrical Connections - Connecting the E1615 Remote Display to the E6000 MASTERLOADx.iQ Register

24V DC Power

If the DC voltage to the LCR.iQ exceeds 24 V, the remote display must be powered from a separate DC-to-DC converter which provides 12 to 24 V.

Follow these steps to connect the remote display to the E6000 register:

1. Open the LCR.iQ register.
2. Attach a cable gland to a port on the LCR.iQ electronic register.
3. Route the shielded cable through the cable gland and into the LCR.iQ register housing.

Shielded Cable

The LectroCount XL LED Remote Display is supplied with a 30 foot 4-wire shielded cable with 22 gauge wire.

If alternate cabling is required, Liquid Controls recommends a similar 4-wire shielded cable with 22 gauge wire or larger and a maximum cable length of 30 feet.

4. Connect the four wires of the display's shielded cable to the four designated terminals on the J9 terminal block on the LCR.iQ CPU board:

- XL LED terminal 53 (red wire) to LCR.iQ terminal 54
- XL LED terminal 54 (white wire) to LCR.iQ terminal 48
- XL LED terminal 55 (green wire) to LCR.iQ terminal 49
- XL LED terminal 56 (black wire) to LCR.iQ terminal 47

J1 Jumper – LectroCount XL LED Remote Display

For proper operation, install a jumper between terminal 52 and 53 on the display's J1 terminal block. Display units from the factory include the jumper. Ensure the jumper is in place when rewiring the display.

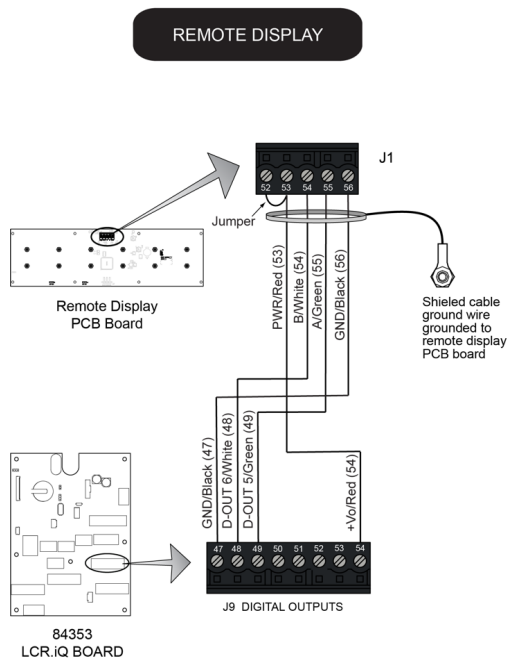

5. Tighten the cable gland and close the LCR.iQ register.

Configure the remote display

Follow these steps to configure the remote display:

1. Navigate to the I/O Setup from the Setup Menu screen and press OK.



2. Navigate to the I/O Setup (4/4) screen.

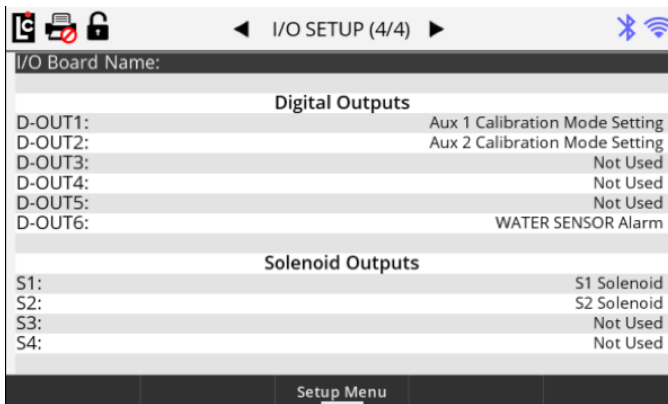

3. Select the D-OUT to which the Green wire is connected and set it to LC XLDisplay A.

4. Select the D-OUT to which the White wire is connected and set it to LC XLDisplay B.

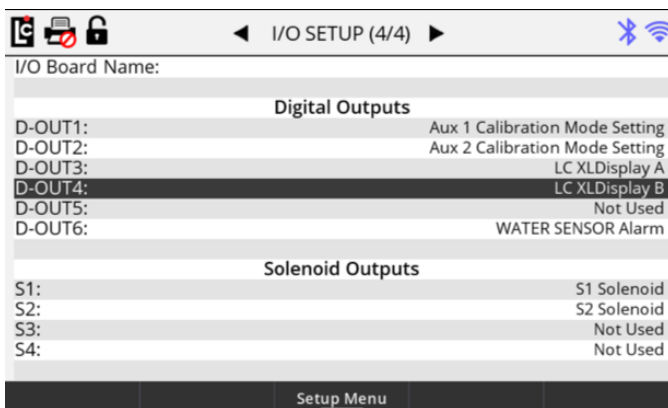

5. Navigate to the Setup Menu screen and press OK.

6. Navigate to the Meter option and press OK.
7. Navigate to the Meter (3/3) screen.

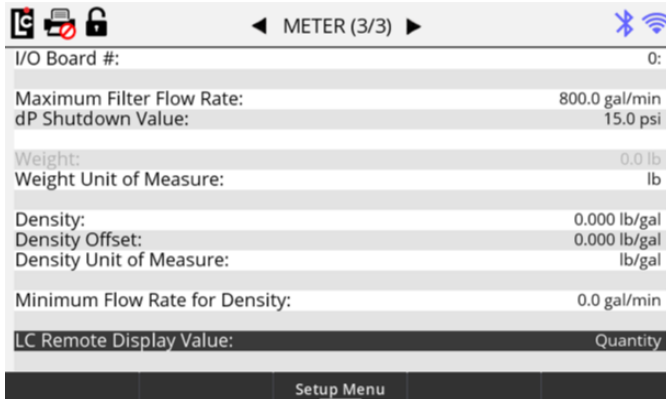

8. Select the LC Remote Display Value option and press OK.
9. Select either the Flow Rate or Quantity option.

Power Supply

When you have made all of the data connections and complete installation of all components, connect the power to the Register and the Epson printer. Before making the power connections, go through the vehicle system checklist below, and ensure that the electrical system of the truck meets the minimum requirements for powering the Register and the Epson printer.

Vehicle System Checklist

- Clean any corrosion from the battery terminals and battery cable to guarantee a solid, tight connection.

Charge the battery according to manufacturer specifications. · Ensure the alternator is large enough to meet the total demands of the truck, including the

Register. The Register requires a minimum of 5 Amps for proper operation. Run the truck at low idle, with all accessories on (including hose reel). Check the voltage with a multimeter to confirm that the voltage doesn't drop below 11 Volts.

- Inspect the electrical equipment on the vehicle to ensure proper installation and operation. · Determine whether the vehicle is grounded positively or negatively. Consult Liquid Controls if the vehicle has a positive ground.

- Ensure that any radio antennas are installed according to manufacturer specifications to prevent RF interference.

Connect the Power

All Register shipments typically include a 50-foot gray power cable (100-foot and 300-foot cables are also available) and a 5 Amp fuse.

This is the wiring diagram for the power supply:

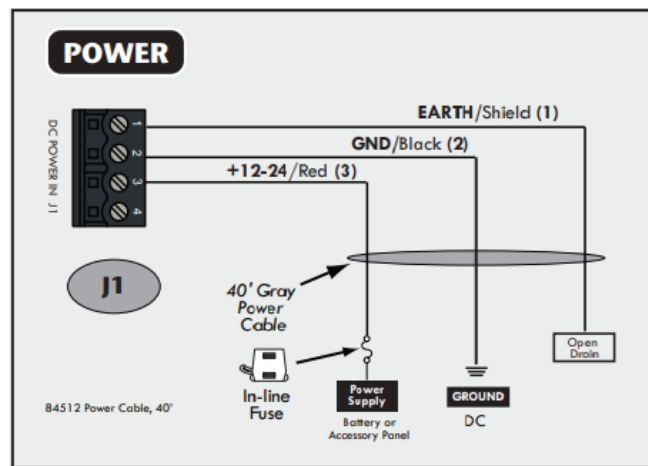

Cable routing

[Routing Data and Power Cables](#) describes the best practices for routing the gray power cable to the truck cab accessory panel.

⁴¹ describes the best practices for routing the gray power

50-foot Gray Power Cable

The gray power cable (PN 84512050) is prewired to the Register board at the factory (meter mount version). It includes two 16AWG wires and a ground drain wire. Splice the 5 Amp fuse into the red 16AWG wire as close to the power source as possible. Panel mount versions will include a loose power cable and must be installed according to the [wiring diagram](#).

Epson Printer Power

Power must be supplied to the Epson printer. For supplying power to the printer, a 15-foot cable with a 12/24VDC converter (825001) is also available. The red wire of this cable must be spliced into the red wire in the gray power cable on the Register side of the 5 Amp fuse.

Follow these steps to connect power to the Register and the Epson printer:

1. Route the gray power cable to the accessory panel. See Routing Data and Power

[Cables](#)  41 .

2. Splice the red wire from the printer power cable into the red wire of the gray power cable.
3. Splice the 5 Amp fuse to the red wire. close to the direct power terminal connection in the accessory panel, and on the power side of the splice made with the printer power cable.
4. Connect the red wire to the direct power supply terminal in the accessory panel.
5. Connect the black wire of the gray power cable to a reliable DC ground.
6. Connect the black wire of the printer power to a reliable DC ground.
7. Tape the green drain wire of the gray power cable back against the power cable.

Power Check

After the Register has been installed, check to ensure that it powers up correctly. The Registerdisplay and the printer power light should come on when the truck ignition is turned either to the **ON** position or the **ACC** position. Ensure that the printer power switch is on. If the Register or the printer does not power up, check the wiring and the connections on the Register board against the instructions in this manual.

Finalize the Installation

IMPORTANT: Before Sealing the Register

After correctly powering up the Register, continue on to the Register Setup and Operation manual to setup the Register for operation. We recommend that you setup and test the Register before closing and sealing the unit.

Close and Seal the Unit

After setting up and testing the unit, complete the installation by closing and sealing the housing. The Register must be environmentally sealed to protect the electronics against the elements. The Register must also be sealed by a Weights & Measures representative to guarantee that the register is operating at the proper regulatory standards.

1. Secure the cables behind the Register and the cables in the cab with cable ties. 2. If conduit was used during the installation, fill the conduit end inside the Register with silicon RTV (provided with shipment, PN 82575). Read and follow the directions of the Environmental Sealing Guidelines, below.
3. Tighten the four socket head cap screws on the four corners of the cover housing using a 3/16 hex key or bit. Ensure that the gap between the cover and the housing is completely closed. Ensure that the calibration screw is tightened to approximately 7-lb—and properly sealed. Read and follow the directions of the Environmental Sealing Guidelines, below.
4. Seal the cover, base, and calibration screw with a wire/lead seal. See the Weights & Measures Seals section below.

Environmental Sealing Guidelines

The Register includes sensitive electronic components, including a microprocessor that can be damaged by the presence of moisture. Therefore, it is essential that all conduit ports, the cover, and the shaft seals be adequately sealed by the installer to ensure watertight integrity. The conformal coating on the board mitigates the problem of corrosion due to moisture, but this measure only protects the board from small amounts of moisture trapped inside when the lid is closed in humid conditions. It is not adequate for protecting the unit over time if a continuous leak is present in the enclosure.

Sealing the Register is the Responsibility of the Installer

There is no product warranty coverage for any water or moisture damage to the Register that results from improper sealing.

1. Conduit Entrances

The Register housing has 11 conduit entrances, all are ½" NPT female threads. Use only ½" NPT male threaded fittings on the conduit entrances. Thread sealant must be used with NPT threads. Pressed-in Caplugs or straight (rather than tapered) threads are inadequate for sealing these entrances. Acceptable fittings include metal or plastic conduit, pipe plugs, or cable glands.

Apply PTFE-based “pipe dope” to threads, or wind a minimum of two revolutions of PTFE tape prior to installation. Engage the threads with a minimum of four full turns. When using cable glands, ensure that the gland is sized properly for the outside diameter of the cable and the elastometric seal around the cable sheath is compressed onto the cable. Use only one cable per cable gland, unless the gland accommodates for multiple cables. When using conduit or Liquid-Tite, ensure that the opposite end is connected to an environmentally sealed device. If the conduit is not sealed at the other device, fill the interior of the conduit at the Register with a silicone rubber sealant—such as RTV—to prevent moisture from running down the conduit into the enclosure.

2. Cover Seals

To seal the Register cover properly, ensure that the O-ring surrounding the cover is fit snug inside the groove, and securely tighten the cover screws.

3. Shaft Seals

Units with internal pulsers have an O-ring around under the pulser inside the enclosure, and also a pulse encoder drive shaft that extends through the bottom of the Register housing. If a drive shaft adapter was attached at installation, ensure the O-ring around the shaft is securely seated in the counter bore of the casting, covered with the flat washer provided, and held in place with the cotter pin provided.

Any water or moisture damage to the Register as result of improper sealing will not be covered under the product warranty. Sealing the Register is the responsibility of the installer.

Weights & Measures Seals

To detect possible intrusions into Weights & Measures approved calibrations on a Register, retainer holes have been drilled into the side of the enclosure adjacent to the Weights &

Measures Screw. Properly tighten the Weights and Measures screw to approximated 7 lb-in of torque or the proper visual tightening.



To seal according to Weights & Measures standards, a wire is threaded through the retainer holes and closed with a lead seal.

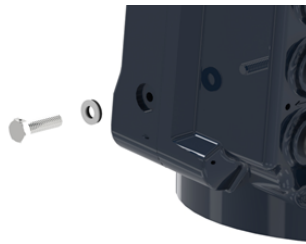

Interface Board Identification

Carte Révision E

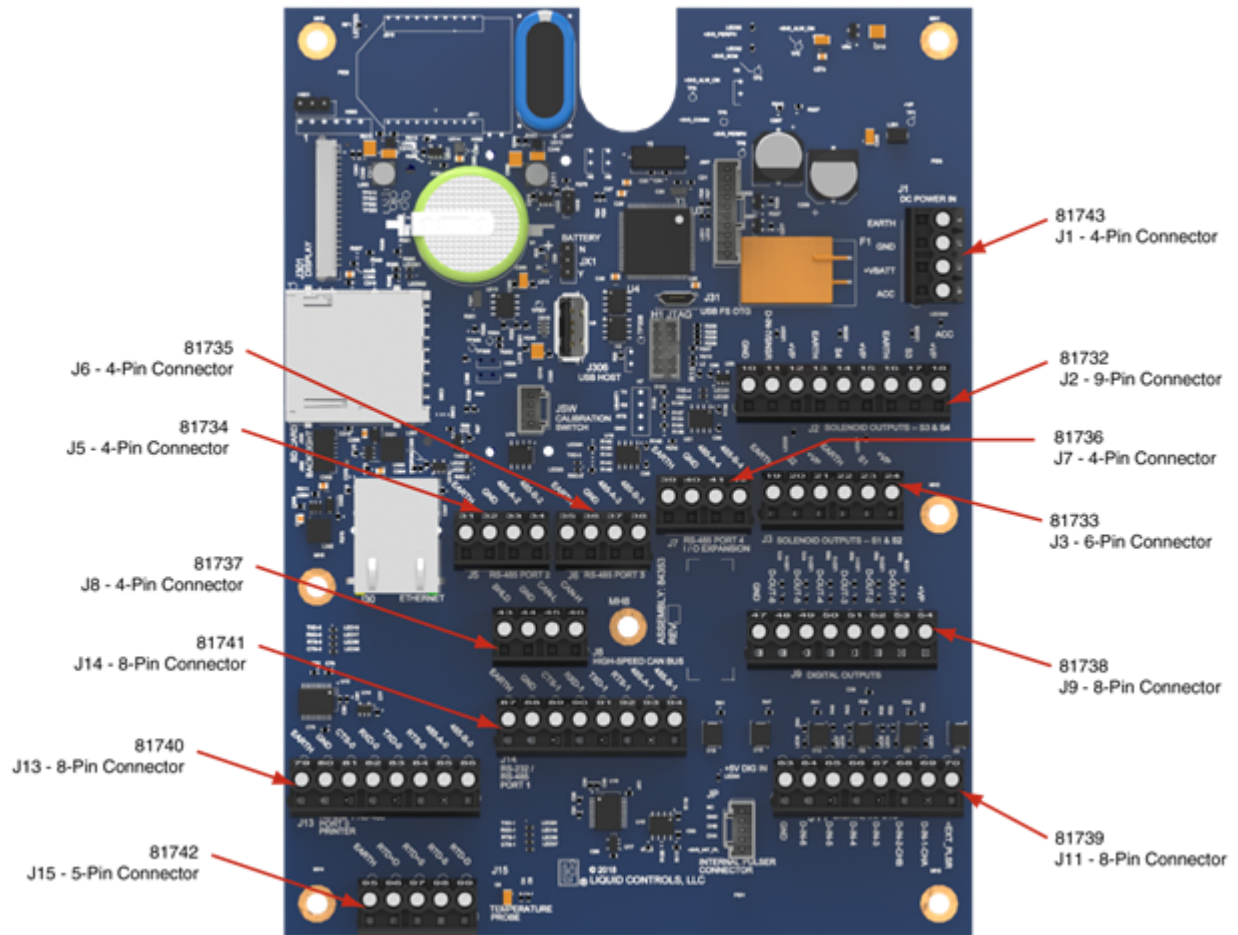

Carte Révision J (identifiée par un J dans le carré blanc indiqué par la flèche)

Pour les cartes Révision J ou ultérieures : remplacer uniquement par un fusible 32 V, 7,5 A, référence 029707.5 fabriqué par Littelfuse ou par un fusible type ATM-7-1/2 fabriqué par Bussmann.

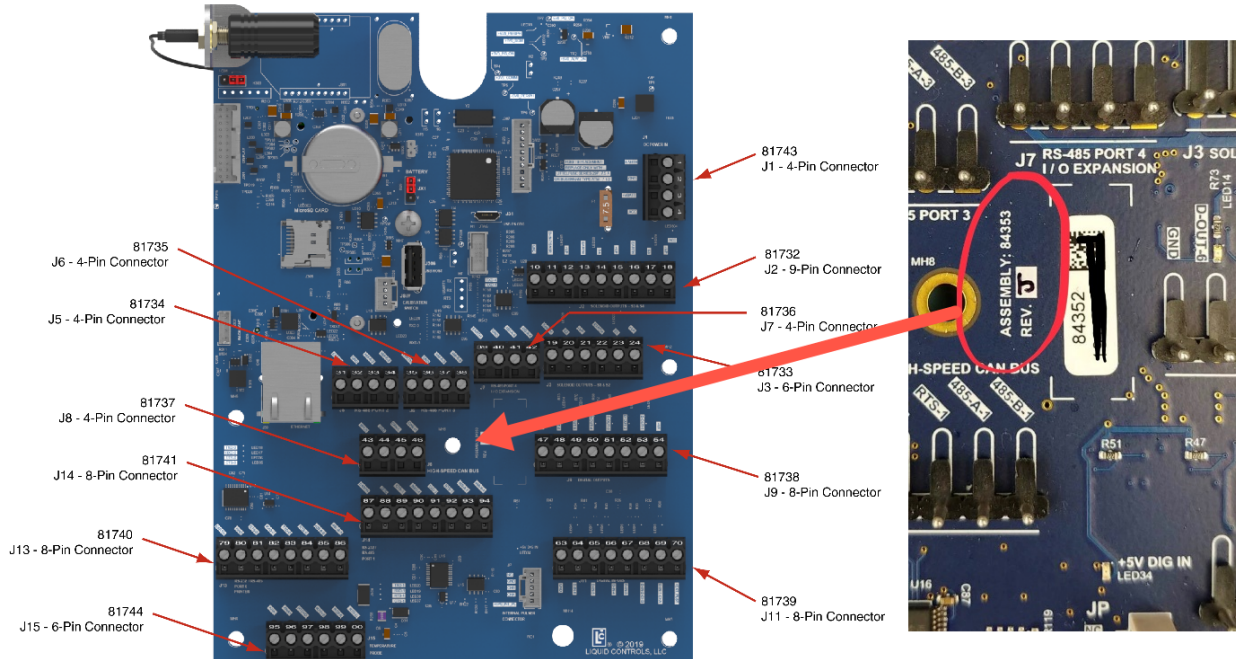



LIQUID CONTROLS



9201 N. I35 Service Rd.
Oklahoma City, OK 73162
1. 800.458.5262
1. 847.295.1050
Fax: 1.847.295.1057
www.LCmeter.com

© 2025 Liquid Controls
LCRiQ_IOM_V1: 06/25